

GenlCam Standard Features Naming Convention (SFNC)

Version 2.4



Table of Content

TABLE OF CONTENT2

TABLE OF FIGURES18

HISTORY.....21

1 INTRODUCTION35

1.1 CONVENTIONS36

1.2 STANDARD UNITS37

1.3 ACRONYMS.....39

1.4 STANDARD DEFINITIONS.....40

1.5 DEVICE COMMUNICATION MODEL41

1.6 DEVICE ACQUISITION MODEL.....41

2 FEATURES SUMMARY.....44

2.1 DEVICE CONTROL44

2.2 IMAGE FORMAT CONTROL48

2.3 ACQUISITION CONTROL51

2.4 ANALOG CONTROL53

2.5 LUT CONTROL54

2.6 COLOR TRANSFORMATION CONTROL54

2.7 DIGITAL I/O CONTROL.....55

2.8 COUNTER AND TIMER CONTROL.....56

2.9 ENCODER CONTROL.....57

2.10 LOGIC BLOCK CONTROL.....58

2.11 SOFTWARE SIGNAL CONTROL.....59

2.12 ACTION CONTROL.....59

2.13 EVENT CONTROL60

2.14 USER SET CONTROL.....62

2.15 SEQUENCER CONTROL62

2.16 FILE ACCESS CONTROL.....63

2.17 SOURCE CONTROL64

2.18 TRANSFER CONTROL64

2.19 SCAN 3D CONTROL.....66

2.20 LIGHT CONTROL68

2.21 CHUNK DATA CONTROL69

2.22 TEST CONTROL72

2.23 GENICAM CONTROL.....73

2.24 TRANSPORT LAYER CONTROL73

3 DEVICE CONTROL81

3.1 DEVICECONTROL.....81

3.2 DEVICETYPE.....81

3.3	DEVICESCANTYPE.....	82
3.4	DEVICEVENDORNAME	82
3.5	DEVICEMODELNAME	83
3.6	DEVICEFAMILYNAME.....	83
3.7	DEVICEMANUFACTURERINFO.....	83
3.8	DEVICEVERSION	84
3.9	DEVICEFIRMWAREVERSION	84
3.10	DEVICERIALNUMBER	84
3.11	DEVICEID (DEPRECATED)	85
3.12	DEVICEUSERID	85
3.13	DEVICSFNCVERSIONMAJOR	85
3.14	DEVICSFNCVERSIONMINOR.....	86
3.15	DEVICSFNCVERSIONSUBMINOR	86
3.16	DEVICEMANIFESTENTRYSELECTOR	86
3.17	DEVICEMANIFESTXMLMAJORVERSION	87
3.18	DEVICEMANIFESTXMLMINORVERSION	87
3.19	DEVICEMANIFESTXMLSUBMINORVERSION	88
3.20	DEVICEMANIFESTSCHEMAMAJORVERSION	88
3.21	DEVICEMANIFESTSCHEMAMINORVERSION	88
3.22	DEVICEMANIFESTPRIMARYURL.....	89
3.23	DEVICEMANIFESTSECONDARYURL.....	89
3.24	DEVICETLTYPE.....	89
3.25	DEVICETLVERSIONMAJOR	90
3.26	DEVICETLVERSIONMINOR.....	90
3.27	DEVICETLVERSIONSUBMINOR	91
3.28	DEVICEGENCPVERSIONMAJOR	91
3.29	DEVICEGENCPVERSIONMINOR.....	91
3.30	DEVICEMAXTHROUGHPUT	92
3.31	DEVICECONNECTIONSELECTOR.....	92
3.32	DEVICECONNECTIONSPEED	92
3.33	DEVICECONNECTIONSTATUS.....	93
3.34	DEVICELINKSELECTOR.....	93
3.35	DEVICELINKSPEED	94
3.36	DEVICELINKTHROUGHPUTLIMITMODE.....	94
3.37	DEVICELINKTHROUGHPUTLIMIT	95
3.38	DEVICELINKCONNECTIONCOUNT.....	95
3.39	DEVICELINKHEARTBEATMODE.....	95
3.40	DEVICELINKHEARTBEATTIMEOUT	96
3.41	DEVICELINKCOMMANDTIMEOUT	96
3.42	DEVICESTREAMCHANNELCOUNT.....	97
3.43	DEVICESTREAMCHANNELSELECTOR	97
3.44	DEVICESTREAMCHANNELTYPE.....	97
3.45	DEVICESTREAMCHANNELLINK	98
3.46	DEVICESTREAMCHANNELENDIANNESS	98
3.47	DEVICESTREAMCHANNELPACKETSIZE	99
3.48	DEVICEEVENTCHANNELCOUNT	99
3.49	DEVICEMESSAGECHANNELCOUNT (DEPRECATED).....	99
3.50	DEVICECHARACTERSET	100

3.51	DEVICERESET	100
3.52	DEVICEINDICATORMODE	101
3.53	DEVICEFEATUREPERSISTENCESTART	101
3.54	DEVICEFEATUREPERSISTENCEEND	101
3.55	DEVICEREGISTERSSTREAMINGSTART	102
3.56	DEVICEREGISTERSSTREAMINGEND	102
3.57	DEVICEREGISTERSCHECK	103
3.58	DEVICEREGISTERSVALID	103
3.59	DEVICEREGISTERSENDIANNESS	103
3.60	DEVICETEMPERATURESELECTOR	104
3.61	DEVICETEMPERATURE.....	104
3.62	DEVICECLOCKSELECTOR	105
3.63	DEVICECLOCKFREQUENCY	105
3.64	DEVICEREGISTERSSELECTOR.....	105
3.65	DEVICEREGISTERSBAUDRATE.....	106
3.66	TIMESTAMP.....	107
3.67	TIMESTAMPRESET	107
3.68	TIMESTAMPLATCH.....	108
3.69	TIMESTAMPLATCHVALUE	108
4	IMAGE FORMAT CONTROL	109
4.1	IMAGEFORMATCONTROL.....	110
4.2	SENSORWIDTH	110
4.3	SENSORHEIGHT	111
4.4	SENSORPIXELWIDTH	111
4.1	SENSORPIXELHEIGHT	111
4.1	SENSORNAME.....	112
4.2	SENSORSHUTTERMODE	112
4.3	SENSORTAPS.....	113
4.4	SENSORDIGITIZATIONTAPS	114
4.5	WIDTHMAX	115
4.6	HEIGHTMAX.....	115
4.7	REGIONSELECTOR	115
4.8	REGIONMODE.....	117
4.9	REGIONDESTINATION	117
4.10	REGIONIDVALUE	118
4.11	COMPONENTSELECTOR.....	118
4.12	COMPONENTENABLE	120
4.13	COMPONENTIDVALUE.....	121
4.14	IMAGECOMPONENTSELECTOR (DEPRECATED)	121
4.15	IMAGECOMPONENTENABLE (DEPRECATED).....	122
4.16	WIDTH	123
4.17	HEIGHT	123
4.18	OFFSETX	124
4.19	OFFSETY	124
4.20	LINEPITCHENABLE	124
4.21	LINEPITCH	125

4.22	BINNINGSELECTOR	125
4.23	BINNINGHORIZONTALMODE	126
4.24	BINNINGHORIZONTAL	126
4.25	BINNINGVERTICALMODE	127
4.26	BINNINGVERTICAL	127
4.27	DECIMATIONHORIZONTALMODE.....	127
4.28	DECIMATIONHORIZONTAL.....	128
4.29	DECIMATIONVERTICALMODE	128
4.30	DECIMATIONVERTICAL	129
4.31	REVERSEX.....	129
4.32	REVERSEY	129
4.33	PIXELFORMAT	130
4.34	PIXELFORMATINFOSELECTOR	136
4.35	PIXELFORMATINFOID	136
4.36	PIXELCODING (DEPRECATED)	137
4.37	PIXELSIZE.....	138
4.38	PIXELCOLORFILTER	139
4.39	PIXELDYNAMICRANGEMIN.....	140
4.40	PIXELDYNAMICRANGEMAX.....	140
4.41	TESTPATTERNGENERATORSELECTOR	140
4.42	TESTPATTERN.....	141
4.43	TESTIMAGESELECTOR (DEPRECATED).....	142
4.44	DEINTERLACING	143
4.45	IMAGE COMPRESSION	144
4.45.1	IMAGECOMPRESSIONMODE.....	144
4.45.2	IMAGECOMPRESSIONRATEOPTION.....	145
4.45.3	IMAGECOMPRESSIONQUALITY	145
4.45.4	IMAGECOMPRESSIONBITRATE	146
4.45.5	IMAGECOMPRESSIONJPEGFORMATOPTION	146
5	ACQUISITION CONTROL.....	148
5.1	ACQUISITION RELATED VOCABULARY AND SIGNALS.....	148
5.2	ACQUISITION FEATURES USAGE MODEL	152
5.3	ACQUISITION TIMING DIAGRAMS	153
5.4	ACQUISITION AND TRIGGER FEATURES USAGE EXAMPLES	164
5.5	ACQUISITION CONTROL FEATURES	169
5.5.1	ACQUISITIONCONTROL.....	169
5.5.2	ACQUISITIONMODE	170
5.5.3	ACQUISITIONSTART.....	170
5.5.4	ACQUISITIONSTOP	171
5.5.1	ACQUISITIONSTOPMODE	171
5.5.2	ACQUISITIONABORT	172
5.5.3	ACQUISITIONARM.....	172
5.5.4	ACQUISITIONFRAMECOUNT.....	173
5.5.5	ACQUISITIONBURSTFRAMECOUNT.....	173
5.5.6	ACQUISITIONFRAMERATE	174
5.5.7	ACQUISITIONFRAMERATEENABLE	174

5.5.8	ACQUISITIONLINERATE	174
5.5.9	ACQUISITIONLINERATEENABLE	175
5.5.10	ACQUISITIONSTATUSSELECTOR	175
5.5.11	ACQUISITIONSTATUS	176
5.6	TRIGGER CONTROL FEATURES	178
5.6.1	TRIGGERSELECTOR	179
5.6.2	TRIGGERMODE	181
5.6.3	TRIGGERSOFTWARE	181
5.6.4	TRIGGERSOURCE	181
5.6.5	TRIGGERACTIVATION	183
5.6.6	TRIGGEROVERLAP	184
5.6.7	TRIGGERDELAY	184
5.6.8	TRIGGERDIVIDER	185
5.6.9	TRIGGERMULTIPLIER	185
5.7	EXPOSURE CONTROL FEATURES	185
5.7.1	EXPOSUREMODE	186
5.7.2	EXPOSURETIMEMODE	187
5.7.3	EXPOSURETIMESSELECTOR	188
5.7.4	EXPOSURETIME	189
5.7.5	EXPOSUREAUTO	189
5.8	MULTI-SLOPE EXPOSURE CONTROL FEATURES	190
5.8.1	MULTISLOPEMODE	195
5.8.2	MULTISLOPEKNEEPOINTCOUNT	195
5.8.3	MULTISLOPEKNEEPOINTSELECTOR	196
5.8.4	MULTISLOPEEXPOSURELIMIT	196
5.8.5	MULTISLOPESATURATIONTHRESHOLD	196
5.8.6	MULTISLOPEINTENSITYLIMIT	197
5.8.7	MULTISLOPEEXPOSUREGRADIENT	197
6	ANALOG CONTROL	199
6.1	ANALOGCONTROL	200
6.2	GAINSELECTOR	200
6.3	GAIN	203
6.4	GAINAUTO	203
6.5	GAINAUTOBALANCE	204
6.6	BLACKLEVELSELECTOR	205
6.7	BLACKLEVEL	206
6.8	BLACKLEVELAUTO	206
6.9	BLACKLEVELAUTOBALANCE	207
6.10	WHITECLIPSELECTOR	208
6.11	WHITECLIP	209
6.12	BALANCERATIOSELECTOR	209
6.13	BALANCERATIO	210
6.14	BALANCEWHITEAUTO	210
6.15	GAMMA	211
7	LUT CONTROL	213

7.1	LUTCONTROL	213
7.2	LUTSELECTOR	213
7.3	LUTENABLE.....	214
7.4	LUTINDEX	214
7.5	LUTVALUE	214
7.6	LUTVALUEALL.....	215
8	COLOR TRANSFORMATION CONTROL	216
8.1	COLORTRANSFORMATIONCONTROL.....	217
8.2	COLORTRANSFORMATIONSELECTOR	217
8.3	COLORTRANSFORMATIONENABLE	218
8.4	COLORTRANSFORMATIONVALUESELECTOR.....	218
8.5	COLORTRANSFORMATIONVALUE	219
9	DIGITAL I/O CONTROL	221
9.1	DIGITAL I/O USAGE MODEL	221
9.2	DIGITAL I/O CONTROL FEATURES.....	223
9.2.1	DIGITALIOCONTROL	223
9.2.2	LINESELECTOR	223
9.2.3	LINEMODE.....	224
9.2.4	LINEINVERTER.....	225
9.2.5	LINESTATUS	225
9.2.6	LINESTATUSALL	226
9.2.7	LINESOURCE.....	226
9.2.8	LINEFORMAT	228
9.2.9	USEROUTPUTSELECTOR	229
9.2.10	USEROUTPUTVALUE	229
9.2.11	USEROUTPUTVALUEALL.....	230
9.2.12	USEROUTPUTVALUEALLMASK.....	230
10	COUNTER AND TIMER CONTROL.....	231
10.1	COUNTER AND TIMER CATEGORY	231
10.1.1	COUNTERANDTIMERCONTROL.....	231
10.2	COUNTER USAGE MODEL	231
10.3	COUNTER FEATURES	233
10.3.1	COUNTERSELECTOR	233
10.3.2	COUNTEREVENTSOURCE	234
10.3.3	COUNTEREVENTACTIVATION.....	236
10.3.4	COUNTERRESETSOURCE.....	236
10.3.5	COUNTERRESETACTIVATION.....	238
10.3.6	COUNTERRESET.....	239
10.3.7	COUNTERVALUE.....	240
10.3.8	COUNTERVALUEATRESET.....	240
10.3.9	COUNTERDURATION.....	240
10.3.10	COUNTERSTATUS	241
10.3.11	COUNTERTRIGGERSOURCE.....	241

10.3.12	COUNTERTRIGGERACTIVATION.....	244
10.4	TIMER USAGE MODEL.....	244
10.5	TIMER FEATURES	247
10.5.1	TIMERSELECTOR.....	247
10.5.2	TIMERDURATION	247
10.5.3	TIMERDELAY	248
10.5.4	TIMERRESET.....	248
10.5.5	TIMERVALUE.....	248
10.5.6	TIMERSTATUS.....	249
10.5.7	TIMERTRIGGERSOURCE.....	249
10.5.8	TIMERTRIGGERACTIVATION.....	251
10.5.9	TIMERTRIGGERARMDELAY.....	252
11	ENCODER CONTROL	253
11.1	QUADRATURE ENCODER USAGE MODEL	253
11.2	ENCODER FEATURES	258
11.2.1	ENCODERCONTROL	258
11.2.2	ENCODERSELECTOR	258
11.2.3	ENCODERSOURCEA	259
11.2.4	ENCODERSOURCEB	259
11.2.5	ENCODERMODE.....	260
11.2.6	ENCODERDIVIDER	260
11.2.7	ENCODEROUTPUTMODE.....	261
11.2.8	ENCODERSTATUS.....	261
11.2.9	ENCODERTIMEOUT	262
11.2.10	ENCODERRESETSOURCE.....	262
11.2.11	ENCODERRESETACTIVATION.....	264
11.2.12	ENCODERRESET.....	265
11.2.13	ENCODERVALUE.....	265
11.2.14	ENCODERVALUEATRESET.....	266
12	LOGIC BLOCK CONTROL	267
12.1	LOGIC BLOCK USAGE MODEL.....	267
12.2	LOGIC BLOCK CONTROL FEATURES	270
12.2.1	LOGICBLOCKCONTROL	270
12.2.2	LOGICBLOCKSELECTOR	271
12.2.3	LOGICBLOCKFUNCTION	271
12.2.4	LOGICBLOCKINPUTNUMBER	272
12.2.5	LOGICBLOCKINPUTSELECTOR.....	272
12.2.6	LOGICBLOCKINPUTSOURCE	273
12.2.7	LOGICBLOCKINPUTINVERTER	275
12.2.8	LOGICBLOCKLUTINDEX	275
12.2.9	LOGICBLOCKLUTVALUE.....	276
12.2.10	LOGICBLOCKLUTVALUEALL	276
12.2.11	LOGICBLOCKLUTSELECTOR.....	276

13 SOFTWARE SIGNAL CONTROL.....	278
13.1 SOFTWARESIGNALCONTROL	278
13.2 SOFTWARESIGNALSELECTOR	278
13.3 SOFTWARESIGNALPULSE.....	279
14 ACTION CONTROL	280
14.1 ACTION USAGE MODEL	280
14.2 ACTION CONTROL FEATURES	281
14.2.1 ACTIONCONTROL	281
14.2.2 ACTIONUNCONDITIONALMODE.....	281
14.2.3 ACTIONDEVICEKEY.....	282
14.2.4 ACTIONQUEUESIZE	282
14.2.5 ACTIONSELECTOR	283
14.2.6 ACTIONGROUPMASK.....	283
14.2.7 ACTIONGROUPKEY	284
15 EVENT CONTROL	285
15.1 EVENTCONTROL	287
15.2 EVENTSELECTOR	287
15.3 EVENTNOTIFICATION.....	291
15.4 FRAME TRIGGER EVENT (EXAMPLE #1).....	292
15.4.1 EVENTFRAMETRIGGERDATA	292
15.4.2 EVENTFRAMETRIGGER.....	292
15.4.3 EVENTFRAMETRiggERTIMESTAMP	293
15.4.4 EVENTFRAMETRIGGERFRAMEID	293
15.5 EXPOSURE END EVENT (EXAMPLE #2)	293
15.5.1 EVENTEXPOSUREENDDATA	294
15.5.2 EVENTEXPOSUREEND.....	294
15.5.3 EVENTEXPOSUREENDTIMESTAMP	294
15.5.4 EVENTEXPOSUREENDFRAMEID	295
15.6 ERROR EVENT (EXAMPLE #3).....	295
15.6.1 EVENTERRORDATA	295
15.6.2 EVENTERROR	296
15.6.3 EVENTERRORTIMESTAMP.....	296
15.6.4 EVENTERRORFRAMEID	296
15.6.5 EVENTERRORCODE	297
15.7 EVENT TEST (EXAMPLE #4).....	297
15.7.1 EVENTTESTDATA	297
15.7.2 EVENTTEST	298
15.7.3 EVENTTESTTIMESTAMP.....	298
16 USER SET CONTROL.....	299
16.1 USERSETCONTROL	299
16.2 USERSETSELECTOR	299
16.3 USERSETLOAD	300

16.4	USERSETSAVE	300
16.5	USERSETDEFAULT	300
16.6	USERSETDEFAULTSELECTOR (DEPRECATED)	301
16.7	USERSETFEATURESELECTOR	302
16.8	USERSETFEATUREENABLE	302
17	SEQUENCER CONTROL	304
17.1	SEQUENCER CONTROL MODEL	304
17.2	SEQUENCER USAGE EXAMPLES	306
17.3	SEQUENCER CONTROL FEATURES	309
17.4	SEQUENCERCONTROL	309
17.5	SEQUENCERMODE	309
17.6	SEQUENCERCONFIGURATIONMODE	309
17.7	SEQUENCERFEATURESELECTOR	310
17.8	SEQUENCERFEATUREENABLE	310
17.9	SEQUENCERSETSELECTOR	311
17.10	SEQUENCERSETSAVE	311
17.11	SEQUENCERSETLOAD	312
17.12	SEQUENCERSETACTIVE	312
17.13	SEQUENCERSETSTART	312
17.14	SEQUENCERPATHSELECTOR	313
17.15	SEQUENCERSETNEXT	313
17.16	SEQUENCERTRIGGERSOURCE	313
17.17	SEQUENCERTRIGGERACTIVATION	315
18	FILE ACCESS CONTROL	317
18.1	FILEACCESSCONTROL	320
18.2	FILESELECTOR	320
18.3	FILEOPERATIONSELECTOR	321
18.4	FILEOPERATIONEXECUTE	322
18.5	FILEOPENMODE	322
18.6	FILEACCESSBUFFER	323
18.7	FILEACCESSOFFSET	323
18.8	FILEACCESSLENGTH	323
18.9	FILEOPERATIONSTATUS	324
18.10	FILEOPERATIONRESULT	324
18.11	FILESIZE	325
19	SOURCE CONTROL	326
19.1	SOURCE CONTROL USAGE MODEL WITH MULTIPLE REGIONS AND TRANSFERS	326
19.2	SOURCE CONTROL FEATURES	329
19.3	SOURCECONTROL	331
19.4	SOURCECOUNT	331
19.5	SOURCESELECTOR	331
19.6	SOURCEIDVALUE	332

20 TRANSFER CONTROL333

20.1	TRANSFER CONTROL MODEL.....	334
20.2	TRANSFER CONTROL FEATURES.....	337
20.3	TRANSFERCONTROL	337
20.4	TRANSFERSELECTOR	337
20.5	TRANSFERCONTROLMODE	338
20.6	TRANSFEROPERATIONMODE	339
20.7	TRANSFERBLOCKCOUNT	339
20.8	TRANSFERBURSTCOUNT	340
20.9	TRANSFERQUEUEMAXBLOCKCOUNT	340
20.10	TRANSFERQUEUECURRENTBLOCKCOUNT	340
20.11	TRANSFERQUEUEMODE	341
20.12	TRANSFERSTART	341
20.13	TRANSFERSTOP	342
20.14	TRANSFERABORT	342
20.15	TRANSFERPAUSE	342
20.16	TRANSFERRESUME	343
20.17	TRANSFERTRIGGERSELECTOR	343
20.18	TRANSFERTRIGGERMODE	344
20.19	TRANSFERTRIGGERSOURCE.....	345
20.20	TRANSFERTRIGGERACTIVATION	346
20.21	TRANSFERSTATUSSELECTOR.....	346
20.22	TRANSFERSTATUS	347
20.23	TRANSFERCOMPONENTSELECTOR	347
20.24	TRANSFERSTREAMCHANNEL.....	348

21 3D SCAN CONTROL349

21.1	3D SCAN USAGE MODEL AND CONFIGURATION SCENARIOS.....	352
21.1.1	3D ACQUISITION DEVICES CONFIGURATION EXAMPLES.....	353
21.2	FORMATTING AND INTERPRETING 3D DATA.....	367
21.2.1	COORDINATE SYSTEMS	368
21.2.2	COORDINATE SYSTEM POSITION AND TRANSFORMATION	369
21.2.3	FOCAL LENGTH AND BASELINE FOR 3D RECONSTRUCTION FROM DISPARITY.....	373
21.3	3D DEVICE DATA OUTPUT CONTROL.....	376
21.3.1	3D DEVICES CONFIGURATION USE CASES.....	378
21.3.1.1	LINESCAN 3D RANGE AND REFLECTANCE OUTPUT.....	378
21.3.1.2	LINESCAN 3D SENSOR’S INTENSITY OUTPUT.....	380
21.3.1.3	LINESCAN 3D HYBRID RANGE, REFLECTANCE AND INTENSITY OUTPUT.....	381
21.3.1.4	LINESCAN 3D RANGE OUTPUT FROM 2 SENSOR REGIONS	382
21.4	SCAN 3D FEATURES.....	384
21.4.1	SCAN3DCONTROL.....	384
21.4.2	SCAN3DEXTRACTIONSELECTOR	384
21.4.3	SCAN3DEXTRACTIONSOURCE.....	385
21.4.4	SCAN3DEXTRACTIONMETHOD	385
21.4.5	SCAN3DDISTANCEUNIT	386
21.4.6	SCAN3DCOORDINATESYSTEM	386

21.4.7	SCAN3DOUTPUTMODE	387
21.4.8	SCAN3DCOORDINATESYSTEMREFERENCE	392
21.4.9	SCAN3DCOORDINATESELECTOR.....	393
21.4.10	SCAN3DCOORDINATESCALE.....	394
21.4.11	SCAN3DCOORDINATEOFFSET	394
21.4.12	SCAN3DINVALIDDATAFLAG.....	395
21.4.13	SCAN3DINVALIDDATAVALUE	395
21.4.14	SCAN3DAXISMIN	396
21.4.15	SCAN3DAXISMAX	396
21.4.16	SCAN3DCOORDINATETRANSFORMSELECTOR.....	397
21.4.17	SCAN3DTRANSFORMVALUE	397
21.4.18	SCAN3DCOORDINATEREFERENCESELECTOR	398
21.4.19	SCAN3DCOORDINATEREFERENCEVALUE	399
21.4.20	SCAN3DFOCALLENGTH	399
21.4.21	SCAN3DBASELINE	400
21.4.22	SCAN3DPRINCIPALPOINTU.....	400
21.4.23	SCAN3DPRINCIPALPOINTV.....	401
22	LIGHT CONTROL.....	402
22.1	EXISTING TIMER FEATURES FOR LIGHT CONTROL	402
22.2	LIGHT CONTROL FEATURES USAGE	402
22.3	LIGHT CONTROL FEATURES.....	405
22.3.1	LIGHTCONTROL.....	405
22.3.2	LIGHTCONTROLLERSELECTOR	405
22.3.3	LIGHTCONTROLLERSOURCE.....	405
22.3.4	LIGHTCURRENTRATING.....	406
22.3.5	LIGHTVOLTAGERATING	406
22.3.6	LIGHTBRIGHTNESS	407
22.3.7	LIGHTCONNECTIONSTATUS.....	407
22.3.8	LIGHTCURRENTMEASURED	407
22.3.9	LIGHTVOLTAGEMEASURED.....	408
23	CHUNK DATA CONTROL.....	409
23.1	CHUNKDATACONTROL.....	411
23.2	CHUNKMODEACTIVE	411
23.3	CHUNKSELECTOR	412
23.4	CHUNKENABLE.....	413
23.5	CHUNKREGIONSELECTOR.....	414
23.6	CHUNKREGIONID.....	415
23.7	CHUNKREGIONIDVALUE.....	415
23.8	CHUNKCOMPONENTSELECTOR.....	416
23.9	CHUNKCOMPONENTID	417
23.10	CHUNKCOMPONENTIDVALUE.....	418
23.11	CHUNKIMAGECOMPONENT (DEPRECATED)	418
23.12	CHUNKPARTSELECTOR (DEPRECATED)	419
23.13	CHUNKIMAGE.....	419

23.14	CHUNKOFFSETX.....	420
23.15	CHUNKOFFSETY.....	420
23.16	CHUNKWIDTH	420
23.17	CHUNKHEIGHT	421
23.18	CHUNKPIXELFORMAT	421
23.19	CHUNKPIXELDYNAMICRANGEMIN	427
23.20	CHUNKPIXELDYNAMICRANGEMAX.....	428
23.21	CHUNKTIMESTAMP.....	428
23.22	CHUNKTIMESTAMPLATCHVALUE	429
23.23	CHUNKLINESTATUSALL.....	429
23.24	CHUNKCOUNTERSELECTOR.....	429
23.25	CHUNKCOUNTERVALUE.....	430
23.26	CHUNKTIMERSELECTOR.....	430
23.27	CHUNKTIMERVALUE.....	431
23.28	CHUNKSCANLINESELECTOR	431
23.29	CHUNKENCODERSELECTOR.....	432
23.30	CHUNKENCODERVALUE.....	432
23.31	CHUNKENCODERSTATUS.....	433
23.32	CHUNKEXPOSURETIMESELECTOR	433
23.33	CHUNKEXPOSURETIME	434
23.34	CHUNKGAINSELECTOR.....	435
23.35	CHUNKGAIN	436
23.36	CHUNKBLACKLEVELSELECTOR	437
23.37	CHUNKBLACKLEVEL.....	438
23.38	CHUNKLINEPITCH	438
23.39	CHUNKFRAMEID	438
23.40	CHUNKSOURCESELECTOR	439
23.41	CHUNKSOURCEID	440
23.42	CHUNKSOURCEIDVALUE	440
23.43	CHUNKTRANSFERBLOCKID	441
23.44	CHUNKTRANSFERSTREAMID	441
23.45	CHUNKTRANSFERQUEUECURRENTBLOCKCOUNT	442
23.46	CHUNKSTREAMCHANNELID	442
23.47	CHUNKSEQUENCERSETACTIVE	442
23.48	CHUNKSCAN3DDISTANCEUNIT	443
23.49	CHUNKSCAN3DOUTPUTMODE	443
23.50	CHUNKSCAN3DCOORDINATESYSTEM	445
23.51	CHUNKSCAN3DCOORDINATESYSTEMREFERENCE.....	445
23.52	CHUNKSCAN3DCOORDINATESELECTOR.....	446
23.53	CHUNKSCAN3DCOORDINATESCALE.....	446
23.54	CHUNKSCAN3DCOORDINATEOFFSET	447
23.55	CHUNKSCAN3DINVALIDDATAFLAG.....	447
23.56	CHUNKSCAN3DINVALIDDATAVALUE	448
23.57	CHUNKSCAN3DAXISMIN	448
23.58	CHUNKSCAN3DAXISMAX	448
23.59	CHUNKSCAN3DCOORDINATETRANSFORMSELECTOR.....	449
23.60	CHUNKSCAN3DTRANSFORMVALUE	449
23.61	CHUNKSCAN3DCOORDINATEREFERENCESELECTOR	450

23.62	CHUNKSCAN3DCOORDINATEREFERENCEVALUE	451
23.63	CHUNKSCAN3DFOCALLENGTH	451
23.64	CHUNKSCAN3DBASELINE.....	452
23.65	CHUNKSCAN3DPRINCIPALPOINTU	452
23.66	CHUNKSCAN3DPRINCIPALPOINTV	453
24	TEST CONTROL.....	454
24.1	TESTCONTROL.....	454
24.2	TESTPENDINGACK.....	454
24.3	TESTEVENTGENERATE	455
24.4	TESTPAYLOADFORMATMODE	455
25	GENICAM CONTROL	457
25.1	GENICAM FEATURE TREE ACCESS.....	457
25.1.1	ROOT	457
25.1.2	DEVICE	457
26	TRANSPORT LAYER CONTROL	459
26.1	TLPARAMSLOCKED USAGE.....	459
26.2	TRANSPORT LAYER FEATURES.....	459
26.2.1	TRANSPORTLAYERCONTROL.....	459
26.2.2	TLPARAMSLOCKED.....	460
26.2.3	TLPARAMSLOCKEDSELECTOR	460
26.2.4	TLPARAMSLOCKEDSTATE	461
26.2.5	PAYLOADSIZE.....	462
26.2.6	DEVICETAPGEOMETRY.....	462
26.3	PTP CONTROL	465
26.3.1	PTPCONTROL	466
26.3.2	PTPENABLE	466
26.3.3	PTPCLOCKACCURACY	467
26.3.4	PTPDATASET LATCH.....	467
26.3.5	PTPSTATUS	468
26.3.6	PTPSERVOSTATUS	468
26.3.7	PTPOFFSETFROMMASTER	469
26.3.8	PTPCLOCKID	469
26.3.9	PTPPARENTCLOCKID	469
26.3.10	PTPGRANDMASTERCLOCKID	470
26.4	GIGE VISION FEATURES	471
26.4.1	GIGEVISION	471
26.4.2	GEVVERSIONMAJOR (DEPRECATED).....	471
26.4.3	GEVVERSIONMINOR (DEPRECATED).....	471
26.4.4	GEVDEVICEMODEISBIGENDIAN (DEPRECATED).....	472
26.4.5	GEVDEVICECLASS (DEPRECATED).....	472
26.4.6	GEVDEVICEMODECHARACTERSET (DEPRECATED).....	473
26.4.7	GEVPHYSICALLINKCONFIGURATION.....	473
26.4.8	GEVCURRENTPHYSICALLINKCONFIGURATION	474

26.4.9	GEVACTIVELINKCOUNT (DEPRECATED)	474
26.4.10	GEVSUPPORTEDOPTIONSELECTOR	474
26.4.11	GEVSUPPORTEDOPTION	476
26.4.12	GEVINTERFACESELECTOR	477
26.4.13	GEVLINKSPEED (DEPRECATED)	477
26.4.14	GEVMACADDRESS	477
26.4.15	GEVPAUSEFRAMERECEPTION	478
26.4.16	GEVPAUSEFRAMETRANSMISSION	478
26.4.17	GEVCURRENTIPCONFIGURATIONLLA	479
26.4.18	GEVCURRENTIPCONFIGURATIONDHCP	479
26.4.19	GEVCURRENTIPCONFIGURATIONPERSISTENTIP	479
26.4.20	GEVCURRENTIPADDRESS	480
26.4.21	GEVCURRENTSUBNETMASK	480
26.4.22	GEVCURRENTDEFAULTGATEWAY	481
26.4.23	GEVIPCONFIGURATIONSTATUS	481
26.4.24	GEVFIRSTURL (DEPRECATED)	481
26.4.25	GEVSECONDURL (DEPRECATED)	482
26.4.26	GEVNUMBEROFINTERFACES (DEPRECATED)	482
26.4.27	GEVPERSISTENTIPADDRESS	483
26.4.28	GEVPERSISTENTSUBNETMASK	483
26.4.29	GEVPERSISTENTDEFAULTGATEWAY	483
26.4.30	GEVMESSAGECHANNELCOUNT (DEPRECATED)	484
26.4.31	GEVSTREAMCHANNELCOUNT (DEPRECATED)	484
26.4.32	GEVHEARTBEATTIMEOUT (DEPRECATED)	485
26.4.33	GEVTIMESTAMP TICKFREQUENCY (DEPRECATED)	485
26.4.34	GEVTIMESTAMPCONTROLLATCH (DEPRECATED)	485
26.4.35	GEVTIMESTAMPCONTROLRESET (DEPRECATED)	486
26.4.36	GEVTIMESTAMPVALUE (DEPRECATED)	486
26.4.37	GEVDISCOVERYACKDELAY	487
26.4.38	GEVIEEE1588 (DEPRECATED)	487
26.4.39	GEVIEEE1588CLOCKACCURACY (DEPRECATED)	487
26.4.40	GEVIEEE1588STATUS (DEPRECATED)	488
26.4.41	GEVVCPEXTENDEDSTATUSCODESSELECTOR	489
26.4.42	GEVVCPEXTENDEDSTATUSCODES	489
26.4.43	GEVVCPPENDINGACK	490
26.4.44	GEVVCPPENDINGHEARTBEATDISABLE (DEPRECATED)	490
26.4.45	GEVVCPPENDINGTIMEOUT (DEPRECATED)	490
26.4.46	GEVPRIMARYAPPLICATIONSWITCHOVERKEY	491
26.4.47	GEVVSPEXTENDEDIDMODE	491
26.4.48	GEVCCP	492
26.4.49	GEVPRIMARYAPPLICATIONSOCKET	492
26.4.50	GEVPRIMARYAPPLICATIONIPADDRESS	493
26.4.51	GEVMCPHOSTPORT	493
26.4.52	GEVMCDA	493
26.4.53	GEVMCTT	494
26.4.54	GEVMCRC	494
26.4.55	GEVMCSP	494
26.4.56	GEVSTREAMCHANNELSELECTOR	495

26.4.57	GEVSCCFGPACKETRESENDDESTINATION	495
26.4.58	GEVSCCFGALLINTRANSMISSION	496
26.4.59	GEVSCCFGUNCONDITIONALSTREAMING.....	496
26.4.60	GEVSCCFGEXTENDEDCHUNKDATA	496
26.4.61	GEVSCPDIRECTION (DEPRECATED).....	497
26.4.62	GEVSCPIINTERFACEINDEX	497
26.4.63	GEVSCPHOSTPORT.....	498
26.4.64	GEVSCPSFIRETESTPACKET.....	498
26.4.65	GEVSCPSDONOTFRAGMENT.....	499
26.4.66	GEVSCPSBIGENDIAN (DEPRECATED).....	499
26.4.67	GEVSCPSPACKETSIZE	499
26.4.68	GEVSCPD	500
26.4.69	GEVSCDA.....	500
26.4.70	GEVSCSP.....	501
26.4.71	GEVSCZONECOUNT	501
26.4.72	GEVSCZONEDIRECTIONALL	502
26.4.73	GEVSCZONECONFIGURATIONLOCK.....	502
26.5	NETWORK STATISTICS FEATURES	503
26.5.1	NETWORKSTATISTICS	503
26.5.2	oMACCONTROLFUNCTIONENTITY	503
26.5.3	APAUSEMACCTRLFRAMESTRANSMITTED.....	504
26.5.4	APAUSEMACCTRLFRAMESRECEIVED	504
26.6	CAMERA LINK FEATURES.....	504
26.6.1	CAMERALINK	504
26.6.2	CLCONFIGURATION	505
26.6.3	CLTIMESLOTSCOUNT	506
26.7	COAXPRESS FEATURES.....	506
26.7.1	COAXPRESS	507
26.7.2	CXP LINK CONFIGURATION STATUS.....	507
26.7.3	CXP LINK CONFIGURATION PREFERRED.....	510
26.7.4	CXP LINK CONFIGURATION	513
26.7.5	CXP CONNECTION SELECTOR	516
26.7.6	CXP CONNECTION TEST MODE	516
26.7.7	CXP CONNECTION TEST ERROR COUNT	517
26.7.8	CXP CONNECTION TEST PACKET COUNT	517
26.7.9	CXP PoCXP AUTO	518
26.7.10	CXP PoCXP TURN OFF.....	518
26.7.11	CXP PoCXP TRIP RESET.....	519
26.7.12	CXP PoCXP STATUS	519
27	ACKNOWLEDGEMENTS	520
28	TAP GEOMETRY APPENDIX.....	521
28.1	MOTIVATIONS.....	521
28.2	IDENTIFYING THE GEOMETRICAL PROPERTIES	521
28.2.1	IMAGE GEOMETRICAL PROPERTIES.....	521
28.2.1.1	RESTRICTIONS	522

28.2.1.2	TAP NAMING CONVENTION	522
28.2.1.3	TAP GEOMETRICAL PROPERTIES	523
28.3	TAP GEOMETRY DRAWINGS	529
28.3.1	SINGLE TAP GEOMETRY	529
	1X-1Y (area-scan).....	529
	1X (line-scan).....	529
28.3.2	DUAL TAP GEOMETRIES	530
	1X2-1Y (area-scan).....	530
	1X2 (line-scan).....	530
	2X-1Y (area-scan).....	530
	2X (line-scan).....	530
	2XE-1Y (area-scan)	531
	2XE (line-scan)	531
	2XM-1Y (area-scan)	531
	2XM (line-scan)	531
	1X-1Y2 (area-scan).....	532
	1X-2YE (area-scan).....	532
28.4	TRIPLE TAP GEOMETRIES	533
	1X3-1Y (area-scan).....	533
	1X3 (line-scan).....	533
	3X-1Y (area-scan).....	533
	3X (line-scan).....	533
28.5	QUAD TAP GEOMETRIES	534
	1X4-1Y (area-scan).....	534
	1X4 (line-scan).....	534
	4X-1Y (area-scan).....	534
	4X (line-scan).....	534
	2X2-1Y (area-scan).....	535
	2X2 (line-scan).....	535
	2X2E-1Y (area-scan)	535
	2X2E (line-scan)	535
	2X2M-1Y (area-scan)	536
	2X2M (line-scan)	536
	1X2-2YE (area-scan).....	536
	2X-2YE (area-scan)	537
	2XE-2YE (area-scan).....	537
	2XM-2YE (area-scan).....	537
28.6	OCTAL TAP GEOMETRIES.....	538
	1X8-1Y (area-scan).....	538
	1X8 (line-scan).....	538
	8X-1Y (area-scan).....	538
	8X (line-scan).....	538
	4X2-1Y (area-scan).....	539
	4X2 (line-scan).....	539
	4X2E-1Y (area-scan)	539
	4X2E (line-scan)	539
	2X2E-2YE (area-scan).....	539
28.7	DECA TAP GEOMETRIES	541

1X10-1Y (area-scan)..... 541
1X10 (line-scan)..... 541
10X1Y (line-scan) 541
10X (line-scan)..... 542

Table of Figures

FIGURE 1-1: DEVICE COMMUNICATION MODEL 41
 FIGURE 1-2: BASIC ACQUISITION DEVICE WITH FIXED CONFIGURATION. 42
 FIGURE 1-3: MULTI-SOURCE, MULTI-REGION ACQUISITION DEVICE WITH DATA STREAM TRANSFER CONTROL. 43
 FIGURE 4-1: IMAGE SIZE AND DEFINING A REGION OF INTEREST 109
 FIGURE 4-2: MULTIPLE IMAGE COMPONENTS FROM A FULL SIZE IMAGE 120
 FIGURE 5-1: ACQUISITION SIGNALS DEFINITION 148
 FIGURE 5-2: BURST SIGNALS DEFINITION 149
 FIGURE 5-3: FRAME SIGNALS DEFINITION..... 150
 FIGURE 5-4: FRAME SIGNALS DEFINITION IN LINESCAN MODE 151
 FIGURE 5-5: CONTINUOUS ACQUISITION 153
 FIGURE 5-6: CONTINUOUS ACQUISITION WITH ACQUISITIONSTART TRIGGER 154
 FIGURE 5-7: CONTINUOUS ACQUISITION WITH FRAMESTART TRIGGER..... 155
 FIGURE 5-8: CONTINUOUS ACQUISITION WITH FRAMEBURSTSTART TRIGGER 156
 FIGURE 5-9: MULTIFRAME ACQUISITION 157
 FIGURE 5-10: MULTI FRAME ACQUISITION WITH ACQUISITIONSTART TRIGGER 158
 FIGURE 5-11: MULTI FRAME ACQUISITION WITH FRAMESTART TRIGGER 159
 FIGURE 5-12: MULTI FRAME ACQUISITION WITH FRAMEBURSTSTART TRIGGER 160
 FIGURE 5-13: SINGLE FRAME ACQUISITION 161
 FIGURE 5-14: SINGLE FRAME ACQUISITION WITH ACQUISITIONSTART TRIGGER 162
 FIGURE 5-15: SINGLE FRAME ACQUISITION WITH FRAMESTART TRIGGER 163
 FIGURE 5-16: TRIGGER GENERATION FUNCTIONAL MODEL 179
 FIGURE 5-17: MULTI-SLOPE EXPOSURE MODEL 191
 FIGURE 5-18: MULTI-SLOPE INTENSITY LIMITS 192
 FIGURE 5-19: MULTI-SLOPE EXPOSURE EXAMPLE. 194
 FIGURE 6-1: GAIN ALL PRE AMPLIFICATION 201
 FIGURE 6-2: GAIN ALL POST AMPLIFICATION 202
 FIGURE 9-1: I/O CONTROL 221
 FIGURE 11-1: ENCODER INTERFACE OVERVIEW..... 254
 FIGURE 11-2: ENCODER POSITION, DIRECTION AND MOTION OUTPUT MODES. 255
 FIGURE 11-3: ENCODER 4 STATES UP AND DOWN COUNTING. 256
 FIGURE 11-4: ENCODER CONTROL INTERFACE AND ENCODER VALUE IN BOTH MOTION TRACKING MODES. 256
 FIGURE 18-1: FILE ACCESS MODEL..... 317
 FIGURE 18-2: LAYOUT OF FILE ACCESS BUFFER. 319
 FIGURE 19-1: MULTI-SOURCE MULTI-REGION DEVICE WITH DATA STREAM TRANSFER CONTROL..... 326
 FIGURE 20-1: ACQUISITION AND TRANSFER DATA FLOW. 334
 FIGURE 20-2: TRANSFER CONTROL SECTION. 335
 FIGURE 20-3: TRANSFER CONTROL STATE..... 336
 FIGURE 21-1: 3D AREASCAN CAMERA. 349
 FIGURE 21-2: 3D POINT CLOUD DATA SET REPRESENTING A CYLINDER. 350
 FIGURE 21-3: 3D LINESCAN CAMERA..... 351
 FIGURE 21-4: 3D INVALID OR MISSING DATA DUE TO OCCLUSION AROUND THE BOX (IN BLACK). 352
 FIGURE 21-5: 3D AREASCAN CAMERA RANGE ACQUISITION..... 353
 FIGURE 21-6: 3D AREASCAN CAMERA RANGE ACQUISITION WITH MULTIPLES REGIONS. 354
 FIGURE 21-7: STEREO CAMERAS GENERATING INDIVIDUAL 3D AND INTENSITY IMAGES FOR EACH SENSORS..... 357
 FIGURE 21-8: LASER LINESCAN TRIANGULATION SENSOR WITH VERTICAL LASER..... 360
 FIGURE 21-9: LASER LINESCAN TRIANGULATION WITH MULTIPLE REGIONS AND COORDINATE SYSTEMS. 363
 FIGURE 21-10: RELATIONSHIP BETWEEN CARTESIAN AND SPHERICAL COORDINATE SYSTEMS..... 368

FIGURE 21-11: RELATIONSHIP BETWEEN CARTESIAN AND CYLINDRICAL COORDINATE SYSTEMS..... 368

FIGURE 21-12: TYPICAL ORIENTATION OF THE AXES FOR A LINESCAN3D CAMERA..... 369

FIGURE 21-13: 3D CAMERA ANCHORS AND TRANSFORMED POSITION AND ORIENTATION. 370

FIGURE 21-14: TRANSFORMATION FROM THE ANCHOR TO THE TRANSFORMED SYSTEM. 371

FIGURE 21-15: RECTIFIED RANGE MAPS (NON-RECTIFIED RANGE MAP IMAGE OBJECTS CLOSER APPEAR LARGER). 372

FIGURE 21-16: RANGE IMAGE REPRESENTED AS 3 IMAGE PLANES, A,B,C. 373

FIGURE 21-17: EXTRACTION OF A,B AND C WORLD COORDINATE INFORMATION IN A RECTIFIED RANGE MAP IMAGE C. 373

FIGURE 21-18: POINT CLOUD RECTIFIED TO UNIFORM X SAMPLING INTERVAL..... 373

FIGURE 21-19: LINESCAN 3D DEVICE REGIONS AND COMPONENTS OUTPUT CONTROL. 376

FIGURE 21-20: TYPICAL LINESCAN 3D ACQUISITION SETUP..... 377

FIGURE 21-21: LINESCAN 3D RANGE AND REFLECTANCE COMPONENTS OUTPUT..... 378

FIGURE 21-22: LINESCAN 3D SENSOR INTENSITY COMPONENTS OUTPUT..... 380

FIGURE 21-23: LINESCAN 3D RANGE ANS REFLECTANCE COMPONENTS OUTPUT. 381

FIGURE 21-24: LINESCAN 3D WITH DUAL RANGE COMPONENTS OUTPUT..... 382

FIGURE 23-1: FRAME WITH CHUNKS DISABLED. 409

FIGURE 23-2: FRAME WITH CHUNKS ENABLED. 409

FIGURE 23-3: ILLUSTRATION OF MULTI-COMPONENT/MULTI-PART DATA AND CHUNKS. 410

FIGURE 28-1: GEOMETRY 1X-1Y (AREA-SCAN) 529

FIGURE 28-2: GEOMETRY 1X (LINE-SCAN)..... 529

FIGURE 28-3: GEOMETRY 1X2-1Y (AREA-SCAN) 530

FIGURE 28-4: GEOMETRY 1X2 (LINE-SCAN)..... 530

FIGURE 28-5: GEOMETRY 2X-1Y (AREA-SCAN) 530

FIGURE 28-6: GEOMETRY 2X (LINE-SCAN)..... 530

FIGURE 28-7: GEOMETRY 2XE-1Y (AREA-SCAN)..... 531

FIGURE 28-8: GEOMETRY 2XE (LINE-SCAN) 531

FIGURE 28-9: GEOMETRY 2XM-1Y (AREA-SCAN)..... 531

FIGURE 28-10: GEOMETRY 2XM (LINE-SCAN) 531

FIGURE 28-11: GEOMETRY 1X-1Y2 (AREA-SCAN) 532

FIGURE 28-12: GEOMETRY 1X-2YE (AREA-SCAN)..... 532

FIGURE 28-13: GEOMETRY 1X3-1Y (AREA-SCAN) 533

FIGURE 28-14: GEOMETRY 1X3 (LINE-SCAN)..... 533

FIGURE 28-15: GEOMETRY 3X-1Y (AREA-SCAN) 533

FIGURE 28-16: GEOMETRY 3X (LINE-SCAN)..... 533

FIGURE 28-17: GEOMETRY 1X4-1Y (AREA-SCAN) 534

FIGURE 28-18: GEOMETRY 1X4 (LINE-SCAN)..... 534

FIGURE 28-19: GEOMETRY 4X-1Y (AREA-SCAN) 534

FIGURE 28-20: GEOMETRY 4X (LINE-SCAN)..... 534

FIGURE 28-21: GEOMETRY 2X2-1Y (AREA-SCAN) 535

FIGURE 28-22: GEOMETRY 2X2 (LINE-SCAN)..... 535

FIGURE 28-23: GEOMETRY 2X2E-1Y (AREA-SCAN)..... 535

FIGURE 28-24: GEOMETRY 2X2E (LINE-SCAN) 535

FIGURE 28-25: GEOMETRY 2X2M-1Y (AREA-SCAN)..... 536

FIGURE 28-26: GEOMETRY 2X2M (LINE-SCAN) 536

FIGURE 28-27: GEOMETRY 1X2-2YE (AREA-SCAN)..... 536

FIGURE 28-28: GEOMETRY 2X-2YE (AREA-SCAN)..... 537

FIGURE 28-29: GEOMETRY 2XE-2YE (AREA-SCAN) 537

FIGURE 28-30: GEOMETRY 2XM-2YE (AREA-SCAN) 537

FIGURE 28-31: GEOMETRY 1X8-1Y (AREA-SCAN) 538

FIGURE 28-32: GEOMETRY 1X8 (LINE-SCAN)..... 538

FIGURE 28-33: GEOMETRY 8X-1Y (AREA-SCAN) 538

FIGURE 28-34: GEOMETRY 8X (LINE-SCAN)..... 538

FIGURE 28-35: GEOMETRY 4X2-1Y (AREA-SCAN) 539

FIGURE 28-36: GEOMETRY 4X2 (LINE-SCAN)..... 539

FIGURE 28-37: GEOMETRY 4X2E-1Y (AREA-SCAN)..... 539

FIGURE 28-38: GEOMETRY 4X2E (LINE-SCAN) 539

FIGURE 28-39: GEOMETRY 2X2E-2YE (AREA-SCAN) 540

FIGURE 28-40: GEOMETRY 1X10-1Y (AREA-SCAN) 541

FIGURE 28-41: GEOMETRY 1X10 (LINE-SCAN).....	541
FIGURE 28-42: GEOMETRY 10X-1Y (LINE-SCAN).....	541
FIGURE 28-43: GEOMETRY 10X (LINE-SCAN).....	542

History

Version	Date	Changed by	Change
Draft 0.01	14.02.2006	Eric Carey, DALSA Coreco	Initial version based on the GenICam standard feature list document of the GigE Vision/GenICam joint sub-committee. This version is intended to be the official feature naming convention to be used for GigE Vision cameras. Original contributors: Basler (Fritz Dierks, Thies Moeller, Andreas Gäer), Leutron Vision (Jan Becvar), DALSA Coreco (Eric Carey), Euresys (Jean-Michel Wintgens), MVTec (Christoph Zierl), National Instruments (Chris Graf), Stemmer (Sascha Dorenbeck), SICK IVP (Mattias Johannesson), JAI (Ole Krogh Jørgensen), Matrox (Stephane Maurice)
Draft 0.02	16.03.2006	Stephane Maurice, Matrox	Define the new Acquisition, Trigger and I/O feature set. Introduced the notion of counters and grouped it with Timers in a separate chapter. Reviewed feature names for consistency and grouping.
Draft 1.00	04.04.2006	Stephane Maurice, Matrox	Included modifications and corrections based on the feedbacks from version 0.02 to 0.9. Final Draft.

Version	Date	Changed by	Change
Draft 1.00.01	06.06.2006	Stephane Maurice, Matrox	<p>Changed PixelSize to Bpp8, Bpp10, ...</p> <p>Removed all “_” in enumerations and all feature names.</p>
Draft 1.00.02	22.06.2006	Stephane Maurice, Matrox	<p>Changed Software Trigger from TriggerMode to TriggerSource to permit 1394 DCAM feature compatibility.</p> <p>Removed ticks as standard unit for Raw time unit.</p> <p>Added AnyEdge as standard signal activation and event type.</p> <p>Added Line0 and UserOutput0 as standard optional names for enumeration.</p> <p>Added AcquisitionFrameRateRaw and AcquisitionLineRateRaw.</p> <p>Defined standard Event numbers that matches the GigEvision Event numbers.</p>
Draft 1.00.03	16.06.2007	Vincent Rowley, Pleora Technologies Inc.	<p>Prepared Version 1.0.</p> <p>Removed the AIA logo.</p> <p>Fixed typos.</p> <p>Added a note with respect to how the GevMACAddress feature should be implemented.</p> <p>Added a note specifying that the GevCurrentIPConfiguration feature should not be used in production GenICam XML files since it will be deprecated in the next version of the present document.</p> <p>Fixed GevTimestampTickFrequency valid range.</p>

Version	Date	Changed by	Change
Draft 1.00.03 cont.	19.06.2007	Stephane Maurice, Matrox	<p>Preparation for Version 1.0 continued:</p> <p>Added a note about the Selector usage specifying that they must not introduce side effect when their value is changed.</p> <p>Removed GigE Vision logo since the Standard Feature List is now part of the</p>

			<p>GenICam standard.</p> <p>Specified that features with big value such as <code>GevMACAddress</code>, <code>GEVTimestampTickFrequency</code> and <code>GEVTimestampValue</code> must be returned as a single 64 bit values.</p>
Release 1.00.00	20.06.2007	Stephane Maurice, Matrox	<p>Final release Version 1.00</p> <p>Note: This release includes all the features as they were defined in the draft 1.00.02 referenced in the final GigE Vision specification version 1.00.</p>
Draft 1.01.01	04.07.2007	Vincent Rowley, Pleora Technologies Inc.	<p>Added <code>SensorTaps</code>, <code>SensorDigitizationTaps</code>, <code>GevCurrentIPConfigurationLLA</code>, <code>GevCurrentIPConfigurationDHCP</code>, <code>GevCurrentIPConfigurationPersistentIP</code> and <code>GevIPConfigurationStatus</code> features.</p> <p>Deprecated <code>GevCurrentIPConfiguration</code>.</p> <p>Added <code>OpenAccess</code> to the list of valid values for the <code>GevCCP</code> feature.</p>
Draft 1.01.02	24.07.2007	Stephane Maurice Matrox	<p>Added the <code>PixelFormat</code> description chapter and note about zero based user bits.</p>
Release 1.1	2.10.2007	Stephane Maurice, Matrox	<p>Final release Version 1.1</p>

Version	Date	Changed by	Change
Draft 1.1.01	10.09.2007	Thies Möller, Basler	Created chapter for File Access.
Draft 1.1.02	12.01.2008	Stephane Maurice, Matrox Vincent Rowley , Pleora	Review and modification to the File Access features proposal.
Release 1.2	29.04.2008	Stephane Maurice, Matrox	SFNC 1.2 including the File Access features and corrections. Also removed the PixelFormat description chapter and GEV event numbers.
Draft 1.2.01	17.07.2008	Karsten Ingeman Christensen, JAI	Merged with recommended visibility proposal from JAI and commented by Vincent Rowley, Pleora
Release 1.2.1	19.08.2008	Stephane Maurice, Matrox	SFNC 1.2.1 including the recommended visibility.
Draft 1.2.12	28.10.2008	Stephane Maurice, Matrox Thies Möller, Basler	Matrox: Created draft for 1.3 including: minors corrections, deprecated Raw and Abs feature and deprecated GigEVision Event, Changed chapters names and created according category features, added Root, Device, TLPParamsLocked, PixelClock, Temperature features and made ICommand optionally readable, ... Basler: Action command was added.
Draft 1.2.13	05.05.2009	Stephane Maurice, Matrox	Deprecated all the GEVSupported... features to regroup them in a selector. Added Color Transformation features. Action command reworked and moved in a separate chapter. Added Event data delivery features.

Version	Date	Changed by	Change
Draft 1.2.14	20.05.2009	Stephane Maurice, Matrox	<p>Deprecated Line0RisingEdge, ...compound enumeration in CounterEventSource and created separate CounterEventActivation and CounterResetActivation features to be consistent with the trigger features.</p> <p>Made CounterValue and TimerValue Writable.</p> <p>Modified descriptions to be able to extract tooltips and descriptions for the reference SFNC XML.</p> <p>Added a VBA macro to be able to generate machine readable version of the SFNC.</p> <p>Added a VBA macro to be able to generate the Features summary (Chapter 2) automatically.</p> <p>Changed units to have a standard notation.</p>
Release 1.3	11.08.2009	Stephane Maurice, Matrox	SFNC 1.3 release including the changes since version 1.2.1.
Draft 1.4	05.01.2009 and 22.01.2010	Vincent Rowley, Pleora Technologies Inc.	<p>Added GigE Vision 1.2 support.</p> <p>Added missing Bpp36 and Bpp48 enumeration entries for PixelSize feature.</p> <p>Added missing RawPacked enumeration entry for PixelCoding feature.</p> <p>Updated support level for GevSCPInterfaceIndex feature in order to be consistent with related features.</p> <p>Clarified text when necessary and fixed typos.</p> <p>Corrected some feature descriptions.</p>

Version	Date	Changed by	Change
Release 1.4	17.03.2010	Stephane Maurice, Matrox	<p>Minor fixes to remove mistakes.</p> <p>YUV422YUYVPacked was removed, changed all the ExposureTimeAuto to ExposureAuto.</p> <p>Corrected GevGVCPPendingAck and GevManifestSecondaryURL names.</p> <p>Added ChunkTimer and ChunkCounter to ChunkSelector.</p> <p>Updated VB macros.</p>
Release 1.5	22.11.2010	Stephane Maurice, Matrox	<ul style="list-style-type: none"> - Added Camera Link related features. - ActionSelector now >0. - Added Bpp30 to PixelSize. - Added RGB16Packed, BGR16Packed, BGR10V1Packed and BGR10V2Packed to pixel Format. - DeviceUserID is now recommended to be an empty string. - GenICam Access chapter added. - DeviceSFNCVersion... features added. - Clarified and corrected points in Counter and Timer chapter. - Added new TimerReset feature and removed LevelHigh and LevelLow in CounterEventActivation of Counter and Timer chapter. - Updated Chunk chapter to correct inconsistencies and add missing items. - Minor fixes to remove mistakes. - Updated VB macros to extract the description of the enumerations and fix other minor parsing issues.

Version	Date	Changed by	Change
Release 1.5.1	20.09.2011	Stephane Maurice, Matrox	<ul style="list-style-type: none"> - Added FrameBurst triggers functionality and their associated features. - Corrected signal names in the figures of the Acquisition control chapter. - Added acquisition timing diagrams in the Acquisition control chapter to illustrate the typical acquisition cases. - Removed and changed some GigE Vision mentions that were too standard specific to accommodate other TL standards. - UserOutputValueAll now mentions that UserOutput0 maps to the Lsb of the register instead of saying Bit 0. - AcquisitionStart is now (Read)/Write instead of Read/Write. - Added Timestamp features. - Added clarifications for Width, WidthMax, Height, and HeightMax. - Added clarifications for the usage of the All enumeration of GainSelector, BlackLevelSelector and WhiteClipSelector. - Replaced AOI per ROI to better match other standards nomenclature. - Made DeviceTapGeometry less Camera Link specific. - Added a note for ExposureTime that the feature is inactive if ExposureAuto is On. - Added a note for AcquisitionLineRate that the feature is inactive if TriggerMode is On. - Minor corrections from 1.5.

Version	Date	Changed by	Change
Draft 1 1.5.2	23.12.2011	Stephane Maurice, Matrox	<ul style="list-style-type: none"> - Moved the document to Word .Docm format (.Docx with macro). - Removed and changed some GigE Vision references that were too standard specific to accommodate other TL standards. - Generalized many GEV features that are now in Device Control chapter to be usable by other TL. - Added DeviceLinkThroughputLimit features. - Updated the PixelFormat and ChunkPixelFormat features and the corresponding text according to the new Pixel Format Naming Convention of the AIA. - Added a standard definitions table and figure.
Draft 2 1.5.2	23.01.2012	Vincent Rowley, Pleora Technologies Inc.	<ul style="list-style-type: none"> - Added GigE Vision 2.0 support. <ul style="list-style-type: none"> o Added ActionLate event. o Added support for link aggregation. o Added support for PAUSE frames. o Added support for extended and standard IDs modes. o Added support for IEEE 1588. o Added support for unconditional and scheduled action commands. o Added support for extended status codes introduced by GigE Vision 2.0. o Added multi-zone support. o Added support for alternate packet resend destination option. o Added support for All-in Transmission mode. - Added PrimaryApplicationSwitch and LinkSpeedChange events. - Added support for 10-tap geometries.

Version	Date	Changed by	Change
Release 2.0	25.10.2012	Stephane Maurice, Matrox	<ul style="list-style-type: none"> - Include all items from 1.5.2 Drafts - Changed all the Mandatory features that were not GenICam related to Recommended to let each TL standards define this. - Replaced "Recommended Visibility" by "Visibility" only. - Added notes to mention that Visibility and Category are recommended. - Deprecated PixelCoding. - Deprecated DeviceID and replaced it with DeviceSerialNumber. - Deprecated TestImageSelector and replaced it with TestPattern. - Deprecated UserSetDefaultSelector and replaced it with UserSetDefault. - Removed all the features and enumerations that were deprecated before this major version of the SFNC. - Added the Device Communication and Device Acquisition Model section. - Added the multiple Region (ROI) handling features (RegionSelector, ...) to the ImageFormat Control chapter. - Added the multiple Source handling features (SourceSelector, ...). - Added the Stream Transfer handling features (TransferSelector, ...). - Added a note for a possible optional DeviceStreamChannelSelector for PayloadSize . - Updated the Selector description section.

Version	Date	Changed by	Change
Release 2.0 (cont.)	25.10.2012	Stephane Maurice, Matrox	<ul style="list-style-type: none"> - Added option to have 0 based Timers, Counters, Actions, Sources, Streams,... - Added the CoaXPress transport layer specific features. - Added the Deinterlacing feature. - Added the Image Compression features. - Added DeviceIndicatorMode feature. - GenICam Access chapter was renamed GenICam Control. - Updated the VB macro.
Release 2.0 (syntax update)	30.10.2012	Stephane Maurice, Matrox	<ul style="list-style-type: none"> - Minor correction to the text format of few features to help the parsing by the VB macro. - Updated the VB macro.
Release 2.1	12.12.2013	Stephane Maurice, Matrox	<ul style="list-style-type: none"> - Added UserSetFeatureSelector and UserSetFeatureEnable features. - Added Sequencer Control category and other sequencer related features. - Added Software Signal Control category and other related features. - Added Geometry_4X2E and Geometry_4X2E_1Y tap geometries. - Deprecated the Gev... features that were redundant with the Device... features (Ex: GevDeviceClass is replaced by the generic DeviceType). - Added PixelFormatInfoSelector and PixelFormatInfoId features. - Update to the CXP TL specific features description. - Allowed PayloadSize to be 0. - Created TimestampLatch, TimestampLatchValue and ChunkTimestampLatchValue features and deprecated their GigE Vision counterpart.

			<ul style="list-style-type: none"> - Deprecated DeviceMessageChannelCount and replaced it with DeviceEventChannelCount. The word Message was also replaced with Event everywhere in the text to be consistent with the Event features name. - Fixed DeviceStreamChannelEndianness by changing it to IEnumeration instead of IBoolean. - Minor corrections to the text. - Updated the VB macro.
Release 2.2	17.12.2014	Stephane Maurice, Matrox	<ul style="list-style-type: none"> - Now referring to PFNC as a sub module of SFNC and located on the EMVA web site. - Updated the Introduction text. - Added SensorShutterMode, BinningHorizontalMode, BinningModeVerticalMode, DecimationHorizontalMode, DecimationVerticalMode. - Added LinkTriggerN as the standard name for the Trigger messages transmitted over the Transport layer. - Added the Test Control category. - Added ExposureTimeSelector and ExposureTimeMode - Included quadrature Encoder features. - Included 3D Scan features. - Made visibility of the Source Control category features Beginner so that it will be visible when selecting beginner's features in other categories. - Added Tap Geometries (2XE-1Y2, 2XM-1Y2, 1X2-1Y2 and 2X-1Y2) and updated all the Tap tables and drawings with a more compact representation. - Added LineTrigger, LineStart and LineEnd, PreviousLine as possible values for certain features to better cover

			<p>Linescan devices,</p> <ul style="list-style-type: none"> - Chapter "Typical standard feature usage examples" was removed and the examples that it was including were moved in their respective chapter. - Reordered chapters in a more functional and logical order. - Updated Acknowledgments with most recent contributors. - Minor corrections to the text. - Updated the VB macro.
Release 2.3	26.5.2016	Stephane Maurice, Matrox	<ul style="list-style-type: none"> - Added 3D features for multiple independent extractions regions support. - Added Processing Modules output Regions support. - Renamed ImageComponentSelector and ImageComponentEnable to ComponentSelector and ComponentEnable to be able to use them for other Component types than image in the future . - Deprecated the Color ComponentSelector enumeration member. Intensity is now used for all the visible light components. - Deprecated ChunkPartSelector that is replaced by ChunkComponentSelector. - Added ChunkComponentSelector, ChunkRegionSelector and ChunkSourceSelector. - Added SourceIDValue, RegionIDValue, ComponentIDValue features and their related Chunk features to be able to differentiate each component sent on the Transport layer using unique component type identifier in the received payload. - Added Trigger Missed handling features. - Added Multi-slope exposure features.

			<ul style="list-style-type: none"> - Added Logic Block Features. - Added LinePitchEnable, AcquisitionFrameRate, AcquisitionLineRate features - Added the new CXP 10 and 12 Gbs modes in the CXP specific features. - Minor corrections to the text. - Updated the VB features extractor macro.
Release 2.4	26.6.2018	Stephane Maurice, Matrox	<ul style="list-style-type: none"> - Added Lighting Control Chapter. - Added TimerTriggerArmDelay feature. - Added some missing ChunkSelector enumerations. - Changed all deprecated features visibility to Invisible. - Clarified DeviceLinkCommandTimeout behavior vs Pending Ack. - Corrected SensorShutterMode category. - Added a RegionSelector example for simultaneous streaming of compressed and uncompressed data. - Added TestPayloadFormatMode. - Moved TLParamsLocked form GenICam Control chapter to the Transport Layer Chapter and changed its category from “None” to TransportLayerControl. - Added TLParamsLockedSelector and TLParamsLockedState to the TransportLayerControl category. - Added SensorPixelWidth, SensorPixelHeight, SensorName. - Added new Precision Time Protocol (PTP) features set and deprecated the Gev1588 equivalent ones. - Added new Focal Length features for 3D reconstruction from Disparity images. - Minor corrections to the text.

			- Updated the VB features extractor macro.
--	--	--	--

1 Introduction

This document contains the GenICam "Standard Features Naming Convention (SFNC)" that provides a standard features naming convention and a standard behavioral model for the devices based on the GenICam standard. The latest release version of all the GenICam standard documents can be found on the [GenICam download page on the EMVA web site](#).

In general, the GenICam technology allows exposing arbitrary features of a camera through a unified API and GUI. Each feature can be defined in an abstract manner by its name, interface type, unit of measurement and behavior. The GenApi module of the GenICam standard defines how to write a camera XML description file that describes the features of a device.

The usage of GenApi alone could be sufficient to make all the features of a camera or a device accessible through the GenICam API. However if the user wants to write generic and portable software for a whole class of cameras or devices and be interoperable, then GenApi alone is not sufficient and the software and the device vendors have to agree on a common naming convention for the standard features. This is the role of the GenICam "Standard Features Naming Convention (SFNC)" to provide a common set of features, their name, and to define a standard behavior for them.

The Standard Features Naming Convention of GenICam is targeting maximum usability and interoperability by existing and future transport layer technologies. In order to achieve this, it provides the definition of standard and transport layer agnostic features and their expected behavior. The goal is to cover and to standardize the naming convention used in all the basic use cases of the devices where the implementation by different vendors would be very similar anyway.

To be GenICam compliant a product must provide a GenICam XML file.

- The GenICam XML file must be compatible with the latest GenApi and schema.
- The GenICam XML file must include all the public features of the product it describes.
- The GenICam XML features must follow the Standard Features Naming Convention whenever applicable or possible.

Those requirements ensure that the users can rely on a complete, consistent and portable feature set for its device and that those features are always accessible in a standard way.

1.1 Conventions

Feature Name and Interface

According to the GenICam standard, all the public features of a device must be included in the GenICam XML file and must use the SFNC Name and Interface type for those features if they exist. Other vendor specific or specialized features not mapping to existing SNFC features can be included but must be located in a vendor specific namespace in the GenICam XML and may use a vendor specific name.

This document lists for each feature, the Name and Interface type that must be used.

Feature Category

With the GenICam standard, each feature should be included in a "Category". The Category element defines in which group of features, the feature will be located.

The Category does not affect the functionality of the features but is used by the GUIs to group the features when displaying them. The purpose is mainly to insure that the GUI can present features in a more organized way.

This document lists for each feature, a recommended Category that should be used.

Feature Level

In this document, features are tagged according to the following requirement levels:

- **M: Mandatory** - Must be implemented to achieve compliance with the GenICam standard.
- **R: Recommended** - This feature adds important aspects to the use case and must respect the naming convention if used.
- **O: Optional** - This feature is less critical. Nevertheless, it is considered and must respect the naming convention if used.

For additional details about the mandatory features specific to a particular transport layers, please refer to the text of those standards.

Feature Visibility

According to the GenICam standard each feature can be assigned a "Visibility". The Visibility defines the type of user that should get access to the feature. Possible values are: Beginner, Expert, Guru and Invisible. The latter is required to make features accessible from the API, but invisible in the GUI.

The visibility does not affect the functionality of the features but is used by the GUI to decide which features to display based on the current user level. The purpose is mainly to insure that the GUI is not cluttered with information that is not intended at the current user level.

The following criteria have been used for the assignment of the recommended visibility:

- **B: Beginner** - Features that should be visible for *all* users via the GUI and API. This is the default visibility in the GenICam XML files and will be used if the Visibility element is omitted for a feature. The number of features with "Beginner" visibility should be limited to all **basic** features of the devices so the GUI display is well-organized and is easy to use.
- **E: Expert** - Features that require a more in-depth knowledge of the camera functionality. This is the preferred visibility level for all advanced features in the cameras.
- **G: Guru** – Advanced features that might bring the cameras into a state where it will not work properly anymore if it is set incorrectly for the cameras current mode of operation.
- **I: Invisible** – Features that should be kept hidden for the GUI users but still be available via the API.

This document lists for each feature, a Visibility that should be used.

Selector

A selector is used to index which instance of the feature is accessed in situations where multiple instances of a feature exist (For instance, the analog gain for each separate channel of the red/green/blue component of a color camera).

A selector is a separate feature that is typically an IEnumeration or an IInteger. Selectors must be used only to select the target features for subsequent changes. It is not allowed to change the behavior of a device in response to a change of a selector value.

If a selector has only one possible value, the selector relation can be omitted but it is recommended to leave the selector feature as read only for information purpose (Ex: TriggerSelector = FrameStart (read only) for a device that has only this trigger type supported).

In this document, the features potentially dependent on a selector are expressed using the C language convention for arrays: a pair of brackets follows the feature name, like in SelectedFeature[Selector]. When the Selector is not present, one must deduce the feature is not an array.

In general, a selector should apply only to a single category of feature (Ex: TriggerSelector applies only to the Trigger related features). However, it is possible that certain more advanced devices will require a selector that applies to features in different categories. For example a device with 2 independent input sensors could have a SourceSelector feature that would select features in the Image Format Control, Acquisition Control, Analog Control, LUT Control and Color Transformation Control categories in order to globally control all the features associated with a particular source (Ex": SourceSelector = Source1, PixelFormat[SourceSelector] = Mono8, Gain[SourceSelector] = 10, AcquisitionStart[SourceSelector]).

Note also that when a feature that has a selector is persisted to a file, the selector is iterated to allow saving the complete array of values and not only the currently selected element.

1.2 Standard Units

The following abbreviations are used as standard units for features described in this document. Note that all units are using plain ASCII characters.

ns	nanoseconds
us	microseconds
ms	milliseconds
mm	millimeter
in	inch
s	seconds
B	Bytes
Bps	Bytes per second
MBps	Mega Bytes per second
Mbps	Mega bits per second
Fps	Frames per second
dB	decibels
C	Celsius
Hz	Hertz
%	Percent

1.3 Acronyms

The following definitions are used in this document.

ADC	Analog to Digital Converter
AGC	Automatic Gain Control
AIA	Automated Imaging Association
CRT	Cathode Ray Tube
DC	Direct Current
DHCP	Dynamic Host Configuration Protocol
EMVA	European Machine Vision Association
ID	Identifier
I/O	Input/Output
IP	Internet Protocol
LLA	Link-Local Address
LUT	Look-Up Table
M	Mandatory
O	Optional
PTP	Precision Time Protocol
R	Recommended or Read (depends on the context)
ROI	Region Of Interest
URL	Uniform Resource Locator
W	Write
XML	eXtensible Markup Language

1.4 Standard Definitions

This section defines the terms used in this document. An illustration of their inter-relation is provided in the

Device Communication Model section below (See Figure 1-1).

<i>Entity</i>	An <i>Entity</i> is an end point located at either side (<i>Host</i> or <i>Device</i>) of a <i>Communication</i> .
<i>Host System</i>	The <i>Host System</i> is the <i>Entity</i> which takes control over a <i>Device</i> . A <i>Host System</i> can be the sink or the source for the data being streamed. Under GenICam the <i>Host System</i> must read and use the GenICam compliant XML file of the <i>Device</i> to control it.
<i>Device</i>	The <i>Device</i> is an <i>Entity</i> which is controlled by a <i>Host System</i> . A <i>Device</i> can be the source or the sink for streaming data. It can be remote (outside the <i>Host System</i>) or local (in the <i>Host System</i>). Under GenICam the <i>Device</i> must provide a GenICam compliant XML file and a register-based control access.
<i>Link</i>	A <i>Link</i> is the virtual binding between a <i>Host System</i> and a <i>Device</i> to establish a <i>Communication</i> . A <i>Link</i> is logical and may use one or more physical <i>Connections</i> .
<i>Connection</i>	A <i>Connection</i> is the physical binding between a <i>Host System</i> and a <i>Device</i> .
<i>Interface</i>	A virtual end point of the <i>Link</i> between a <i>Device</i> and a <i>Host System</i> .
<i>Adapter</i>	A physical entity located in the <i>Host System</i> that has one or many <i>Interfaces</i> .
<i>Communication</i>	A <i>Communication</i> is an exchange of information between two <i>Entities</i> using a <i>Link</i> .
<i>Channel</i>	A logical point-to-point <i>Communication</i> over a <i>Link</i> . There may be multiple <i>Channels</i> on a single <i>Link</i> .
<i>Transport Layer</i>	The layer of <i>Communication</i> responsible to transport information between <i>Entities</i> .
<i>Transmitter</i>	An <i>Entity</i> which acts as the source for streaming data. This may apply to a <i>Host System</i> or a <i>Device</i> .
<i>Receiver</i>	An <i>Entity</i> which acts as the sink for streaming data. This may apply to a <i>Host System</i> or a <i>Device</i> .
<i>Transceiver</i>	An <i>Entity</i> which can receive and transmit streaming data. This may apply to a <i>Host System</i> or a <i>Device</i> .
<i>Peripheral</i>	An <i>Entity</i> which neither acts as a source nor as a sink for streaming data but can be controlled.
<i>Stream</i>	A flow of data that comes from a source and goes to a sink. A data <i>Stream</i> can be composed of images or chunk of data.
<i>Stream Channel</i>	A <i>Communication Channel</i> used to transmit a data <i>Stream</i> from a <i>Transmitter</i> (or <i>Transceiver</i>) to a <i>Receiver</i> (or <i>Transceiver</i>).
<i>Event Channel</i>	A <i>Communication Channel</i> used by the <i>Device</i> to notify the <i>Host System</i> asynchronously of <i>Events</i> . The <i>Host System</i> could also use a <i>Event Channel</i> to communicate events to the <i>Device</i> .
<i>Control Channel</i>	A <i>Communication Channel</i> used to configure and control a <i>Device</i> . For a <i>Control Channel</i> the <i>Device</i> acts as a server that provides the initial point of <i>Communication</i> for the <i>Host System</i> that acts as a Client. The <i>Communication</i> on a <i>Control Channel</i>

	is bidirectional and initiated by the <i>Host System</i> .
<i>Event</i>	An asynchronous notification of the occurrence of a fact. <i>Events</i> are transmitted on an <i>Event Channel</i> .

1.5 Device Communication Model

This section presents the general communication model for the devices controlled using the SFNC. It presents the main elements involved in the communication for control and data streaming between the Host System and the acquisition Device.

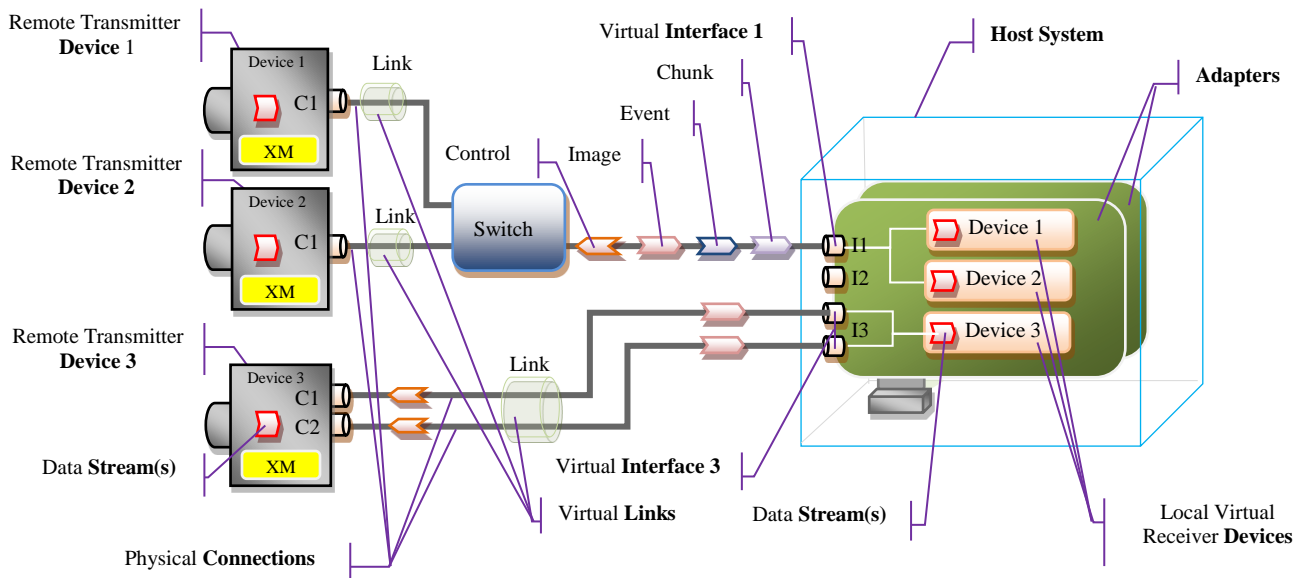

Figure 1-1: Device Communication Model

In general, the Device Communication model is:

- The remote Device and the Host System communicate using a virtual Link.
- The virtual Link is established on an Interface using one or more physical Connections.
- The Host System controls the remote Device using the features present in its GenICam XML file.
- The remote Transmitter Device has a data Source that generates a data Stream.
- The data Stream is sent to the Host System on a Stream Channel of the virtual Link.
- The reception of the data Stream on a Host Interface is handled by a local receiver Device.
- The local receiver Device writes the data Stream to the Host System memory.

See section 1.4 Standard Definitions section above for more detailed information.

1.6 Device Acquisition Model

This section presents the general data acquisition model for the devices controlled using the SFNC. It

presents the main elements involved in the data acquisition by a Device and the typical data flow for transfer of images to the Host System. It covers the typical devices with a single data source and the more complex devices with multi-source, multi-region of interest and data transfer control.

Basic acquisition Devices with one source of data, one region of interest and automatic control of the transfer of data such as the one shown in Figure 1-2, are simple particular case of this model where the Source, Region and Transfer features are fixed and cannot be changed (so the corresponding fixed features can be omitted).

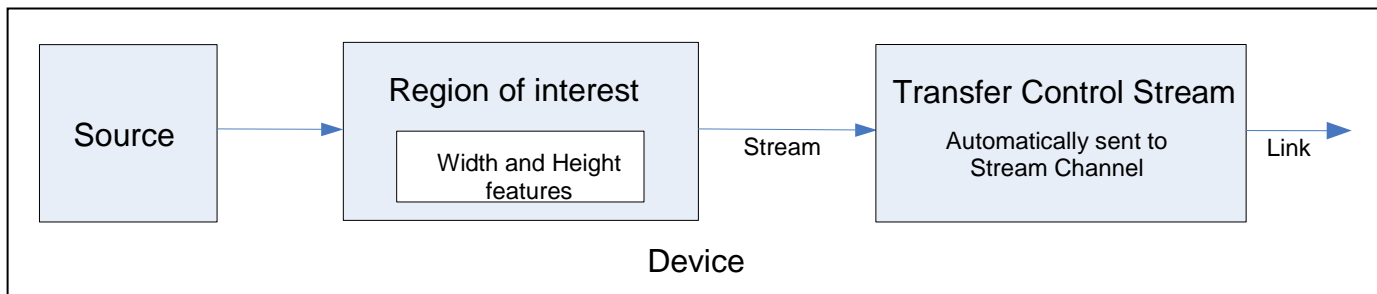

Figure 1-2: Basic acquisition device with fixed configuration.

The typical features setting for such a basic device where the values of Source, Region and Transfer Control Stream are fixed is typically reduced to:

```

Width = 320
Height = 240
AcquisitionStart
...
AcquisitionStop
  
```

But in general, for more complex devices, the acquisition and data transfer model is:

A Device has one or many Source(s).

A Source has one or many Region(s) of interest.

A Region of interest goes to a data Stream.

The data generation by the Source is controlled by the "Acquisition Control" features.

The dimensions of a Region of interest are controlled by the "Image Format Control" features.

The outgoing data flow of a Stream is controlled by a "Transfer Control" features.

The output of the Transfer Control module goes to a Stream Channel.

The Stream Channel is transmitted on a virtual Link.

The virtual Link is established with a Host System using one or many Device's physical Connection(s).

Figure 1-3 below presents an example of a more complex device supporting multi-source, multi-region with data stream transfer control.

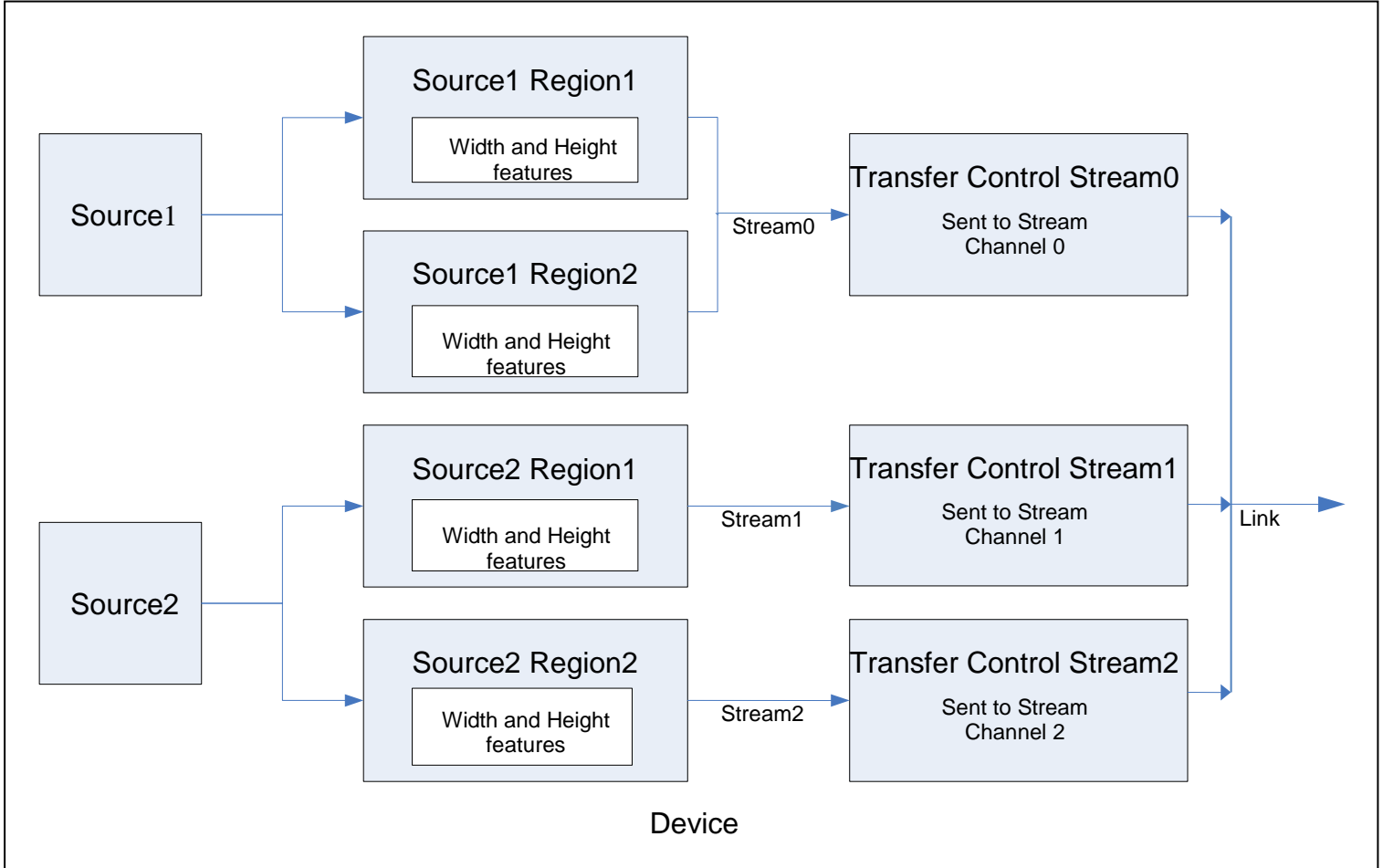

Figure 1-3: Multi-source, multi-region acquisition device with data stream transfer control.

The typical feature setting model for such a complex multi-source device is presented in detail the chapter 19 (Source Control). The features for the control of the regions of interest and image format handling are documented in chapter 4 (Image Format Control) and chapter 20 (Transfer Control) presents the features to control the flow of data on the external link.

2 Features Summary

This chapter provides a comprehensive summary of the standard features covered by this document. The following chapters provide more detailed explanation of each feature.

In case of discrepancy, the sections describing the features in detail prevail.

2.1 Device Control

Contains the features related to the control and information of the device (See the [Device Control](#) chapter for details).

Table 2-1: Device Control Summary

Name	Level	Interface	Access	Unit	Visibility	Description
DeviceControl	R	ICategory	R	-	B	Category for device information and control.
DeviceType	O	IEnumeration	R	-	G	Returns the device type.
DeviceScanType	R	IEnumeration	R/(W)	-	E	Scan type of the sensor of the device.
DeviceVendorName	R	IString	R	-	B	Name of the manufacturer of the device.
DeviceModelName	R	IString	R	-	B	Model of the device.
DeviceFamilyName	O	IString	R	-	B	Identifier of the product family of the device.
DeviceManufacturerInfo	R	IString	R	-	B	Manufacturer information about the device.
DeviceVersion	R	IString	R	-	B	Version of the device.
DeviceFirmwareVersion	R	IString	R	-	B	Version of the firmware in the device.
DeviceSerialNumber	R	IString	R	-	E	Device's serial number.
DeviceID	R	IString	R	-	I	This feature is deprecated (See DeviceSerialNumber).
DeviceUserID	O	IString	R/W	-	B	User-programmable device identifier.
DeviceSFNCVersionMajor	R	IInteger	R	-	B	Major version of the Standard Features Naming Convention that was used to create the device's GenICam XML.
DeviceSFNCVersionMinor	R	IInteger	R	-	B	Minor version of the Standard Features Naming Convention that was

						used to create the device's GenICam XML.
DeviceSFNCVersionSubMinor	R	IInteger	R	-	B	Sub minor version of Standard Features Naming Convention that was used to create the device's GenICam XML.
DeviceManifestEntrySelector	O	IInteger	R/W	-	G	Selects the manifest entry to reference.
DeviceManifestXMLMajorVersion [DeviceManifestEntrySelector]	O	IInteger	R	-	G	Indicates the major version number of the GenICam XML file of the selected manifest entry.
DeviceManifestXMLMinorVersion [DeviceManifestEntrySelector]	O	IInteger	R	-	G	Indicates the minor version number of the GenICam XML file of the selected manifest entry.
DeviceManifestXMLSubMinorVersion [DeviceManifestEntrySelector]	O	IInteger	R	-	G	Indicates the subminor version number of the GenICam XML file of the selected manifest entry.
DeviceManifestSchemaMajorVersion [DeviceManifestEntrySelector]	O	IInteger	R	-	G	Indicates the major version number of the schema file of the selected manifest entry.
DeviceManifestSchemaMinorVersion [DeviceManifestEntrySelector]	O	IInteger	R	-	G	Indicates the minor version number of the schema file of the selected manifest entry.
DeviceManifestPrimaryURL [DeviceManifestEntrySelector]	O	IString	R	-	G	Indicates the first URL to the GenICam XML device description file of the selected manifest entry.
DeviceManifestSecondaryURL [DeviceManifestEntrySelector]	O	IString	R	-	G	Indicates the second URL to the GenICam XML device description file of the selected manifest entry.
DeviceTLType	R	IEnumeration	R	-	B	Transport Layer type of the device.
DeviceTLVersionMajor	R	IInteger	R	-	B	Major version of the Transport Layer of the device.
DeviceTLVersionMinor	R	IInteger	R	-	B	Minor version of the Transport Layer of the device.
DeviceTLVersionSubMinor	R	IInteger	R	-	B	Sub minor version of the Transport Layer of the device.
DeviceGenCPVersionMajor	R	IInteger	R	-	B	Major version of the GenCP protocol supported by the device.
DeviceGenCPVersionMinor	R	IInteger	R	-	B	Minor version of the GenCP protocol supported by the device.
DeviceMaxThroughput	O	IInteger	R	Bps	E	Maximum bandwidth of the data that can be streamed out of the device.
DeviceConnectionSelector	R	IInteger	R/(W)	-	B	Selects which Connection of the device to control.
DeviceConnectionSpeed [DeviceConnectionSelector]	O	IInteger	R	Bps	E	Indicates the speed of transmission of the specified Connection.

DeviceConnectionStatus [DeviceConnectionSelector]	O	IEnumeration	R	-	E	Indicates the status of the specified Connection.
DeviceLinkSelector	R	IInteger	R/(W)	-	B	Selects which Link of the device to control.
DeviceLinkSpeed [DeviceLinkSelector]	O	IInteger	R	Bbs	E	Indicates the speed of transmission negotiated on the specified Link.
DeviceLinkThroughputLimitMode [DeviceLinkSelector]	R	IEnumeration	R/W	-	E	Controls if the DeviceLinkThroughputLimit is active.
DeviceLinkThroughputLimit [DeviceLinkSelector]	R	IInteger	R/(W)	Bps	E	Limits the maximum bandwidth of the data that will be streamed out by the device on the selected Link.
DeviceLinkConnectionCount [DeviceLinkSelector]	O	IInteger	R	-	B	Returns the number of physical connection of the device used by a particular Link.
DeviceLinkHeartbeatMode [DeviceLinkSelector]	O	IEnumeration	R/W	-	E	Activate or deactivate the Link's heartbeat.
DeviceLinkHeartbeatTimeout [DeviceLinkSelector]	O	IFloat	R/W	us	G	Controls the current heartbeat timeout of the specific Link.
DeviceLinkCommandTimeout [DeviceLinkSelector]	O	IFloat	R	us	G	Indicates the command timeout of the specified Link.
DeviceStreamChannelCount	O	IInteger	R	-	E	Indicates the number of streaming channels supported by the device.
DeviceStreamChannelSelector	O	IInteger	R/W	-	E	Selects the stream channel to control.
DeviceStreamChannelType [DeviceStreamChannelSelector]	O	IEnumeration	R	-	G	Reports the type of the stream channel.
DeviceStreamChannelLink [DeviceStreamChannelSelector]	O	IInteger	R/(W)	-	G	Index of device's Link to use for streaming the specified stream channel.
DeviceStreamChannelEndianness [DeviceStreamChannelSelector]	O	IEnumeration	R/(W)	-	G	Endianness of multi-byte pixel data for this stream.
DeviceStreamChannelPacketSize [DeviceStreamChannelSelector]	R	IInteger	R/(W)	B	E	Specifies the stream packet size, in bytes, to send on the selected channel for a Transmitter or specifies the maximum packet size supported by a receiver.
DeviceEventChannelCount	O	IInteger	R	-	E	Indicates the number of event channels supported by the device.

DeviceMessageChannelCount	O	IInteger	R	-	I	This feature is deprecated (See DeviceEventChannelCount).
DeviceCharacterSet	O	IEnumeration	R	-	G	Character set used by the strings of the device's bootstrap registers.
DeviceReset	R	ICommand	W	-	G	Resets the device to its power up state.
DeviceIndicatorMode	O	IEnumeration	R/W	-	E	Controls the behavior of the indicators (such as LEDs) showing the status of the Device.
DeviceFeaturePersistenceStart	O	ICommand	(R)/W	-	G	Indicate to the device and GenICam XML to get ready for persisting of all streamable features.
DeviceFeaturePersistenceEnd	O	ICommand	(R)/W	-	G	Indicate to the device the end of feature persistence.
DeviceRegistersStreamingStart	R	ICommand	(R)/W	-	G	Prepare the device for registers streaming without checking for consistency.
DeviceRegistersStreamingEnd	R	ICommand	(R)/W	-	G	Announce the end of registers streaming.
DeviceRegistersCheck	R	ICommand	(R)/W	-	E	Perform the validation of the current register set for consistency.
DeviceRegistersValid	R	IBoolean	R	-	E	Returns if the current register set is valid and consistent.
DeviceRegistersEndianness	O	IEnumeration	R/(W)	-	G	Endianness of the registers of the device.
DeviceTemperatureSelector	O	IEnumeration	R/W	-	E	Selects the location within the device, where the temperature will be measured.
DeviceTemperature [DeviceTemperatureSelector]	O	IFloat	R	C	E	Device temperature in degrees Celsius (C).
DeviceClockSelector	O	IEnumeration	R/(W)	-	E	Selects the clock frequency to access from the device.
DeviceClockFrequency [DeviceClockSelector]	O	IFloat	R/(W)	Hz	E	Returns the frequency of the selected Clock.
DeviceSerialPortSelector	R	IEnumeration	R/(W)	-	E	Selects which serial port of the device to control.
DeviceSerialPortBaudRate [DeviceSerialPortSelector]	R	IEnumeration	R/(W)	-	E	This feature controls the baud rate used by the selected serial port.
Timestamp	R	IInteger	R	ns	E	Reports the current value of the device timestamp counter.
TimestampReset	O	ICommand	(R)/W	-	E	Resets the current value of the device timestamp counter.
TimestampLatch	O	ICommand	(R)/W	-	E	Latches the current timestamp counter into TimestampLatchValue.

TimestampLatchValue	O	IInteger	R	ns	E	Returns the latched value of the timestamp counter.
---------------------	---	----------	---	----	---	---

2.2 Image Format Control

Contains the features related to the format of the transmitted image (See the [Image Format Control](#) chapter for details).

Table 2-2: Image Format Control Summary

Name	Level	Interface	Access	Unit	Visibility	Description
ImageFormatControl	R	ICategory	R	-	B	Category for Image Format Control features.
SensorWidth	R	IInteger	R	-	E	Effective width of the sensor in pixels.
SensorHeight	R	IInteger	R	-	E	Effective height of the sensor in pixels.
SensorPixelWidth	O	IFloat	R	um	G	Physical size (pitch) in the x direction of a photo sensitive pixel unit.
SensorPixelHeight	O	IFloat	R	um	G	Physical size (pitch) in the y direction of a photo sensitive pixel unit.
SensorName	O	IString	R	-	G	Product name of the imaging Sensor.
SensorShutterMode	O	IEnumeration	R/(W)	-	G	Specifies the shutter mode of the device.
SensorTaps	O	IEnumeration	R/(W)	-	E	Number of taps of the camera sensor.
SensorDigitizationTaps	O	IEnumeration	R/(W)	-	E	Number of digitized samples outputted simultaneously by the camera A/D conversion stage.
WidthMax	R	IInteger	R	-	E	Maximum width of the image (in pixels).
HeightMax	R	IInteger	R	-	E	Maximum height of the image (in pixels).
RegionSelector	O	IEnumeration	R/(W)	-	B	Selects the Region of interest to control.
RegionMode[RegionSelector]	O	IEnumeration	R/W	-	B	Controls if the selected Region of interest is active and streaming.
RegionDestination[RegionSelector]	O	IEnumeration	R/(W)	-	E	Control the destination of the selected region.
RegionIDValue[RegionSelector]	O	IInteger	R	-	E	Returns a unique Identifier value that corresponds to the selected Region.
ComponentSelector	O	IEnumeration	R/W	-	B	Selects a component to activate/deactivate its data streaming.

ComponentEnable[RegionSelector][ComponentSelector]	O	IBoolean	R/(W)	-	B	Controls if the selected component streaming is active.
ComponentIDValue[ComponentSelector]	O	IInteger	R	-	E	Returns a unique Identifier value that corresponds to the selected Component type.
ImageComponentSelector	O	IEnumeration	R/W	-	I	This feature is deprecated (See ComponentSelector).
ImageComponentEnable[RegionSelector][ComponentSelector]	O	IBoolean	R/(W)	-	I	This feature is deprecated (See ComponentEnable).
Width[RegionSelector]	R	IInteger	R/(W)	-	B	Width of the image provided by the device (in pixels).
Height[RegionSelector]	R	IInteger	R/(W)	-	B	Height of the image provided by the device (in pixels).
OffsetX[RegionSelector]	R	IInteger	R/W	-	B	Horizontal offset from the origin to the region of interest (in pixels).
OffsetY[RegionSelector]	R	IInteger	R/W	-	B	Vertical offset from the origin to the region of interest (in pixels).
LinePitchEnable[RegionSelector]	R	IBoolean	R/W	-	E	This feature controls whether the LinePitch feature is writable.
LinePitch[RegionSelector]	R	IInteger	R/W	B	E	Total number of bytes between the starts of 2 consecutive lines.
BinningSelector	O	IEnumeration	R/(W)	-	E	Selects which binning engine is controlled by the BinningHorizontal and BinningVertical features.
BinningHorizontalMode[BinningSelector]	O	IEnumeration	R/(W)	-	E	Sets the mode to use to combine horizontal photo-sensitive cells together when BinningHorizontal is used.
BinningHorizontal[BinningSelector]	O	IInteger	R/W	-	E	Number of horizontal photo-sensitive cells to combine together.
BinningVerticalMode[BinningSelector]	O	IEnumeration	R/(W)	-	E	Sets the mode to use to combine vertical photo-sensitive cells together when BinningVertical is used.
BinningVertical[BinningSelector]	O	IInteger	R/W	-	E	Number of vertical photo-sensitive cells to combine together.
DecimationHorizontalMode	O	IEnumeration	R/(W)	-	E	Sets the mode used to reduce the horizontal resolution when DecimationHorizontal is used.
DecimationHorizontal	O	IInteger	R/W	-	E	Horizontal sub-sampling of the image.
DecimationVerticalMode	O	IEnumeration	R/(W)	-	E	Sets the mode used to reduce the Vertical resolution when DecimationVertical is used.
DecimationVertical	O	IInteger	R/W	-	E	Vertical sub-sampling of the image.

ReverseX	R	IBoolean	R/W	-	E	Flip horizontally the image sent by the device.
ReverseY	R	IBoolean	R/W	-	E	Flip vertically the image sent by the device.
PixelFormat[ComponentSelector]	R	IEnumeration	R/(W)	-	B	Format of the pixels provided by the device.
PixelFormatInfoSelector	R	IEnumeration	R/W	-	G	Select the pixel format for which the information will be returned.
PixelFormatInfoID[PixelFormatInfoSelector]	R	IInteger	R	-	G	Returns the value used by the streaming channels to identify the selected pixel format.
PixelCoding	R	IEnumeration	R/(W)	-	I	This feature is deprecated.
PixelSize[ComponentSelector]	R	IEnumeration	R/(W)	-	E	Total size in bits of a pixel of the image.
PixelColorFilter[ComponentSelector]	R	IEnumeration	R/(W)	-	E	Type of color filter that is applied to the image.
PixelDynamicRangeMin[ComponentSelector]	O	IInteger	R/W	-	E	Minimum value that can be returned during the digitization process.
PixelDynamicRangeMax[ComponentSelector]	O	IInteger	R/W	-	E	Maximum value that will be returned during the digitization process.
TestPatternGeneratorSelector	O	IEnumeration	R/(W)	-	B	Selects which test pattern generator is controlled by the TestPattern feature.
TestPattern[TestPatternGeneratorSelector]	O	IEnumeration	R/W	-	B	Selects the type of test pattern that is generated by the device as image source.
TestImageSelector	O	IEnumeration	R/W	-	I	This feature is deprecated (See TestPattern).
Deinterlacing	O	IEnumeration	R/W	-	B	Controls how the device performs de-interlacing.
ImageCompressionMode	O	IEnumeration	R/W	-	B	Enable a specific image compression mode as the base mode for image transfer.
ImageCompressionRateOption	O	IEnumeration	R/W	-	E	Two rate controlling options are offered: fixed bit rate or fixed quality.
ImageCompressionQuality	O	IInteger	R/(W)	-	E	Control the quality of the produced compressed stream.
ImageCompressionBitrate	O	IFloat	R/(W)	Mbps	E	Control the rate of the produced compressed stream.
ImageCompressionJPEGFormatOption	O	IEnumeration	R/W	-	E	When JPEG is selected as the compression format, a device might optionally offer better control over JPEG-specific options through this feature.

2.3 Acquisition Control

Contains the features related to image acquisition, including trigger and exposure control (See the [Acquisition Control](#) chapter for details).

Table 2-3: Acquisition Control Summary

Name	Level	Interface	Access	Unit	Visibility	Description
AcquisitionControl	R	ICategory	R	-	B	Category for the acquisition and trigger control features.
AcquisitionMode	R	IEnumeration	R/(W)	-	B	Sets the acquisition mode of the device.
AcquisitionStart	R	ICommand	(R)/W	-	B	Starts the Acquisition of the device.
AcquisitionStop	R	ICommand	(R)/W	-	B	Stops the Acquisition of the device at the end of the current Frame.
AcquisitionStopMode	O	IEnum	R/W	-	E	Controls how the AcquisitionStop command and the acquisition stopped using a trigger (e.
AcquisitionAbort	R	ICommand	(R)/W	-	E	Aborts the Acquisition immediately.
AcquisitionArm	O	ICommand	(R)/W	-	E	Arms the device before an AcquisitionStart command.
AcquisitionFrameCount	R	IInteger	R/W	-	B	Number of frames to acquire in MultiFrame Acquisition mode.
AcquisitionBurstFrameCount	O	IInteger	R/W	-	B	Number of frames to acquire for each FrameBurstStart trigger.
AcquisitionFrameRate	R	IFloat	R/W	Hz	B	Controls the acquisition rate (in Hertz) at which the frames are captured.
AcquisitionFrameRateEnable	R	IBoolean	R/W	-	E	Controls if the AcquisitionFrameRate feature is writable and used to control the acquisition rate.
AcquisitionLineRate	R	IFloat	R/W	Hz	B	Controls the rate (in Hertz) at which the Lines in a Frame are captured.
AcquisitionLineRateEnable	R	IBoolean	R/W	-	E	Controls if the AcquisitionLineRate feature is writable and used to control the acquisition rate.
AcquisitionStatusSelector	R	IEnumeration	R/W	-	E	Selects the internal acquisition signal to read using AcquisitionStatus.
AcquisitionStatus[AcquisitionStatusSelector]	R	IBoolean	R	-	E	Reads the state of the internal acquisition signal selected using AcquisitionStatusSelector.
TriggerSelector	R	IEnumeration	R/W	-	B	Selects the type of trigger to configure.
TriggerMode[TriggerSelector]	R	IEnumeration	R/W	-	B	Controls if the selected trigger is active.

TriggerSoftware[TriggerSelector]	R	ICommand	(R)/W	-	B	Generates an internal trigger.
TriggerSource[TriggerSelector]	R	IEnumeration	R/W	-	B	Specifies the internal signal or physical input Line to use as the trigger source.
TriggerActivation[TriggerSelector]	R	IEnumeration	R/W	-	B	Specifies the activation mode of the trigger.
TriggerOverlap[TriggerSelector]	R	IEnumeration	R/W	-	E	Specifies the type trigger overlap permitted with the previous frame or line.
TriggerDelay[TriggerSelector]	R	IFloat	R/W	us	E	Specifies the delay in microseconds (us) to apply after the trigger reception before activating it.
TriggerDivider[TriggerSelector]	R	IInteger	R/W	-	E	Specifies a division factor for the incoming trigger pulses.
TriggerMultiplier[TriggerSelector]	R	IInteger	R/W	-	E	Specifies a multiplication factor for the incoming trigger pulses.
ExposureMode	R	IEnumeration	R/W	-	B	Sets the operation mode of the Exposure.
ExposureTimeMode	O	IEnumeration	R/W	-	B	Sets the configuration mode of the ExposureTime feature.
ExposureTimeSelector	O	IEnumeration	R/W	-	B	Selects which exposure time is controlled by the ExposureTime feature.
ExposureTime[ExposureTimeSelector]	R	IFloat	R/W	us	B	Sets the Exposure time when ExposureMode is Timed and ExposureAuto is Off.
ExposureAuto	O	IEnumeration	R/W	-	B	Sets the automatic exposure mode when ExposureMode is Timed.
MultiSlopeMode	O	IEnumeration	R/W	-	B	Controls multi-slope exposure state.
MultiSlopeKneePointCount	O	IInteger	R/W	-	E	The number of knee-points as well as the number of additional exposure slopes used for multi-slope exposure.
MultiSlopeKneePointSelector	O	IInteger	R/W	-	E	Selects the parameters for controlling an additional slope in multi-slope exposure.
MultiSlopeExposureLimit[MultiSlopeKneePointSelector]	O	IFloat	R/W	%	E	Percent of the ExposureTime at a certain knee-point of multi-slope exposure.
MultiSlopeSaturationThreshold[MultiSlopeKneePointSelector]	O	IFloat	R/(W)	%	E	The percentage of the full saturation that is applied at a certain knee-point of a multi-slope exposure.
MultiSlopeIntensityLimit[MultiSlopeKneePointSelector]	O	IFloat	R/(W)	%	E	The relative intensity which divides intensities influenced by different exposure slopes.
MultiSlopeExposureGradient[MultiSlopeKneePointSelector]	O	IFloat	R/(W)	-	E	The gradient of the additional slope that is defined by this knee-point.

eKneePointSelector]

2.4 Analog Control

Contains the features related to the video signal conditioning in the analog domain (See the [Analog Control](#) chapter for details).

Table 2-4: Analog Control Summary

Name	Level	Interface	Access	Unit	Visibility	Description
AnalogControl	O	ICategory	R	-	B	Category that contains the Analog control features.
GainSelector	O	IEnumeration	R/W	-	B	Selects which Gain is controlled by the various Gain features.
Gain[GainSelector]	O	IFloat	R/W	-	B	Controls the selected gain as an absolute physical value.
GainAuto[GainSelector]	O	IEnumeration	R/W	-	B	Sets the automatic gain control (AGC) mode.
GainAutoBalance	O	IEnumeration	R/W	-	B	Sets the mode for automatic gain balancing between the sensor color channels or taps.
BlackLevelSelector	O	IEnumeration	R/W	-	E	Selects which Black Level is controlled by the various Black Level features.
BlackLevel[BlackLevelSelector]	O	IFloat	R/W	-	E	Controls the analog black level as an absolute physical value.
BlackLevelAuto[BlackLevelSelector]	O	IEnumeration	R/W	-	E	Controls the mode for automatic black level adjustment.
BlackLevelAutoBalance	O	IEnumeration	R/W	-	E	Controls the mode for automatic black level balancing between the sensor color channels or taps.
WhiteClipSelector	O	IEnumeration	R/W	-	E	Selects which White Clip to control.
WhiteClip[WhiteClipSelector]	O	IFloat	R/W	-	E	Controls the maximal intensity taken by the video signal before being clipped as an absolute physical value.
BalanceRatioSelector	O	IEnumeration	R/W	-	E	Selects which Balance ratio to control.
BalanceRatio[BalanceRatioSelector]	O	IFloat	R/W	-	E	Controls ratio of the selected color component to a reference color component.
BalanceWhiteAuto	O	IEnumeration	R/W	-	E	Controls the mode for automatic white balancing between the color channels.

Gamma	O	IFloat	R/W	-	B	Controls the gamma correction of pixel intensity.
-------	---	--------	-----	---	---	---

2.5 LUT Control

Contains the features related to the look-up table (LUT) control (See the [LUT Control](#) chapter for details).

Table 2-5: Lut Control Summary

Name	Level	Interface	Access	Unit	Visibility	Description
LUTControl	O	ICategory	R	-	E	Category that includes the LUT control features.
LUTSelector	O	IEnumeration	R/W	-	E	Selects which LUT to control.
LUTEnable[LUTSelector]	O	IBoolean	R/W	-	E	Activates the selected LUT.
LUTIndex[LUTSelector]	O	IInteger	R/W	-	G	Control the index (offset) of the coefficient to access in the selected LUT.
LUTValue[LUTSelector][LUTIndex]	O	IInteger	R/W	-	G	Returns the Value at entry LUTIndex of the LUT selected by LUTSelector.
LUTValueAll[LUTSelector]	O	IRegister	R/W	-	G	Accesses all the LUT coefficients in a single access without using individual LUTIndex.

2.6 Color Transformation Control

Contains the features related to the control of the color transformation (See the [Color Transformation Control](#) chapter for details).

Table 2-6: Color Transformation summary

Name	Level	Interface	Access	Unit	Visibility	Description
ColorTransformationControl	R	ICategory	R	-	E	Category that contains the Color Transformation control features.
ColorTransformationSelector	O	IEnumeration	R/W	-	E	Selects which Color Transformation module is controlled by the various Color Transformation features.
ColorTransformationEnable[ColorTransformationSelector]	O	IBoolean	R/W	-	E	Activates the selected Color Transformation module.

ColorTransformationValueSelector[ColorTransformationSelector]	O	IEnumeration	R/W	-	E	Selects the Gain factor or Offset of the Transformation matrix to access in the selected Color Transformation module.
ColorTransformationValue[ColorTransformationSelector][ColorTransformationValueSelector]	O	IFloat	R/W	-	E	Represents the value of the selected Gain factor or Offset inside the Transformation matrix.

2.7 Digital I/O Control

Contains the features related to the control of the input and output pins of the device (See the [Digital I/O Control](#) chapter for details).

Table 2-7: Digital I/O Control Summary

Name	Level	Interface	Access	Unit	Visibility	Description
DigitalIOControl	R	ICategory	R	-	E	Category that contains the digital input and output control features.
LineSelector	R	IEnumeration	R/W	-	E	Selects the physical line (or pin) of the external device connector or the virtual line of the Transport Layer to configure.
LineMode[LineSelector]	O	IEnumeration	R/W	-	E	Controls if the physical Line is used to Input or Output a signal.
LineInverter[LineSelector]	R	IBoolean	R/W	-	E	Controls the inversion of the signal of the selected input or output Line.
LineStatus[LineSelector]	R	IBoolean	R	-	E	Returns the current status of the selected input or output Line.
LineStatusAll	O	IInteger	R	-	E	Returns the current status of all available Line signals at time of polling in a single bitfield.
LineSource[LineSelector]	R	IEnumeration	R/W	-	E	Selects which internal acquisition or I/O source signal to output on the selected Line.
LineFormat[LineSelector]	O	IEnumeration	R/W	-	E	Controls the current electrical format of the selected physical input or output Line.
UserOutputSelector	R	IEnumeration	R/W	-	E	Selects which bit of the User Output register will be set by UserOutputValue.
UserOutputValue[UserOutputSelector]	R	IBoolean	R/W	-	E	Sets the value of the bit selected by UserOutputSelector.
UserOutputValueAll	O	IInteger	R/W	-	E	Sets the value of all the bits of the User Output register.
UserOutputValueAllMask	O	IInteger	R/W	-	E	Sets the write mask to apply to the value specified by

UserOutputValueAll before writing it in the User Output register.

2.8 Counter and Timer Control

Contains the features related to the usage of programmable counters and timers (See the [Counter and Timer Control](#) chapter for details).

Table 2-8: Counter and Timer Control Summary

Name	Level	Interface	Access	Unit	Visibility	Description
CounterAndTimerControl	R	ICategory	R	-	E	Category that contains the Counter and Timer control features.
CounterSelector	R	IEnumeration	R/W	-	E	Selects which Counter to configure.
CounterEventSource[CounterSelector]	R	IEnumeration	R/W	-	E	Select the events that will be the source to increment the Counter.
CounterEventActivation[CounterSelector]	R	IEnumeration	R/W	-	E	Selects the Activation mode Event Source signal.
CounterResetSource[CounterSelector]	R	IEnumeration	R/W	-	E	Selects the signals that will be the source to reset the Counter.
CounterResetActivation[CounterSelector]	R	IEnumeration	R/W	-	E	Selects the Activation mode of the Counter Reset Source signal.
CounterReset[CounterSelector]	R	ICommand	(R)/W	-	E	Does a software reset of the selected Counter and starts it.
CounterValue[CounterSelector]	R	IInteger	R/W	-	E	Reads or writes the current value of the selected Counter.
CounterValueAtReset[CounterSelector]	R	IInteger	R	-	E	Reads the value of the selected Counter when it was reset by a trigger or by an explicit CounterReset command.
CounterDuration[CounterSelector]	R	IInteger	R/W	-	E	Sets the duration (or number of events) before the CounterEnd event is generated.
CounterStatus[CounterSelector]	R	IEnumeration	R	-	E	Returns the current status of the Counter.
CounterTriggerSource[CounterSelector]	R	IEnumeration	R/W	-	E	Selects the source to start the Counter.
CounterTriggerActivation[CounterSelector]	R	IEnumeration	R/W	-	E	Selects the activation mode of the trigger to start the Counter.
TimerSelector	R	IEnumeration	R/W	-	E	Selects which Timer to configure.
TimerDuration[TimerSelector]	R	IFloat	R/W	us	E	Sets the duration (in microseconds) of the Timer pulse.

TimerDelay[TimerSelector]	R	IFloat	R/W	us	E	Sets the duration (in microseconds) of the delay to apply at the reception of a trigger before starting the Timer.
TimerReset[TimerSelector]	R	ICommand	(R)/W	-	E	Does a software reset of the selected timer and starts it.
TimerValue[TimerSelector]	R	IFloat	R/W	us	E	Reads or writes the current value (in microseconds) of the selected Timer.
TimerStatus[TimerSelector]	R	IEnumeration	R	-	E	Returns the current status of the Timer.
TimerTriggerSource[TimerSelector]	R	IEnumeration	R/W	-	E	Selects the source of the trigger to start the Timer.
TimerTriggerActivation[TimerSelector]	R	IEnumeration	R/W	-	E	Selects the activation mode of the trigger to start the Timer.
TimerTriggerArmDelay[TimerSelector]	R	IFloat	R/W	us	E	Sets the duration of the delay to apply before to enable the reception of a new Timer trigger.

2.9 Encoder Control

Contains the features related to the usage of quadrature encoders (See the [Encoder Control](#) chapter for details).

Table 2-9: Quadrature Encoder Control Summary

Name	Level	Interface	Access	Unit	Visibility	Description
EncoderControl	O	ICategory	R	-	B	Category that contains the quadrature Encoder Control features.
EncoderSelector	O	IEnumeration	R/W	-	E	Selects which Encoder to configure.
EncoderSourceA[EncoderSelector]	O	IEnumeration	R/W	-	E	Selects the signal which will be the source of the A input of the Encoder.
EncoderSourceB[EncoderSelector]	O	IEnumeration	R/W	-	E	Selects the signal which will be the source of the B input of the Encoder.
EncoderMode[EncoderSelector]	O	IEnumeration	R/W	-	E	Selects if the count of encoder uses FourPhase mode with jitter filtering or the HighResolution mode without jitter filtering.
EncoderDivider[EncoderSelector]	O	IInteger	R/W	-	E	Sets how many Encoder increment/decrements are needed to generate an Encoder output pulse signal.
EncoderOutputMode[EncoderSelector]	O	IEnumeration	R/W	-	E	Selects the conditions for the Encoder interface to generate a valid Encoder output signal.

EncoderStatus[EncoderSelector]	O	IEnumeration	R	-	E	Returns the motion status of the encoder.
EncoderTimeout[EncoderSelector]	O	IFloat	R/W	us	E	Sets the maximum time interval between encoder counter increments before the status turns to static.
EncoderResetSource[EncoderSelector]	R	IEnumeration	R/W	-	E	Selects the signals that will be the source to reset the Encoder.
EncoderResetActivation[EncoderSelector]	R	IEnumeration	R/W	-	E	Selects the Activation mode of the Encoder Reset Source signal.
EncoderReset[EncoderSelector]	R	ICommand	(R)/W	-	E	Does a software reset of the selected Encoder and starts it.
EncoderValue[EncoderSelector]	R	IInteger	R/W	-	E	Reads or writes the current value of the position counter of the selected Encoder.
EncoderValueAtReset[EncoderSelector]	R	IInteger	R	-	E	Reads the value of the of the position counter of the selected Encoder when it was reset by a signal or by an explicit EncoderReset command.

2.10 Logic Block Control

Contains the features related to the usage of the logic block (See the [Logic Block Control](#) chapter for details).

Table 2-10: Logic Block Control Summary

Name	Level	Interface	Access	Unit	Visibility	Description
LogicBlockControl	O	ICategory	R	-	G	Category that contains the Logic Block control features.
LogicBlockSelector	O	IEnumeration	R/W	-	G	Specifies the Logic Block to configure.
LogicBlockFunction[LogicBlockSelector]	O	IEnumeration	R/W	-	G	Selects the combinational logic Function of the Logic Block to configure.
LogicBlockInputNumber[LogicBlockSelector]	O	IInteger	R/(W)	-	G	Specifies the number of active signal inputs of the Logic Block.
LogicBlockInputSelector[LogicBlockSelector]	O	IInteger	R/W	-	G	Selects the Logic Block's input to configure.
LogicBlockInputSource[LogicBlockSelector][LogicBlockInputSelector]	O	IEnumeration	R/W	-	G	Selects the source signal for the input into the Logic Block.
LogicBlockInputInverter[LogicBlockSelector]	O	IBoolean	R/W	-	G	Selects if the selected Logic Block Input source signal is inverted.

ector][LogicBlockInputSelector]						
LogicBlockLUTIndex[LogicBlockSelector]	O	IInteger	R/W	-	G	Controls the index of the truth table to access in the selected LUT.
LogicBlockLUTValue[LogicBlockSelector][LogicBlockLUTIndex]	O	IBoolean	R/W	-	G	Read or Write the Value associated with the entry at index LogicBlockLUTIndex of the selected LUT.
LogicBlockLUTValueAll[LogicBlockSelector]	O	IInteger	R/W	-	G	Sets the values of all the output bits of the selected LUT in one access ignoring LogicBlockLUTIndex.
LogicBlockLUTSelector[LogicBlockSelector]	O	IEnumeration	R/W	-	G	Selects which of the two LUTs to configure when the selected Logic Block is a Latched dual LUTs (i.

2.11 Software Signal Control

Contains the features related to the control of the Software Signal (See the [Software Signal Control](#) chapter for details).

Table 2-11: Software Signal Control Summary

Name	Level	Interface	Access	Unit	Visibility	Description
SoftwareSignalControl	O	ICategory	R	-	B	Category that contains the Software Signal Control features.
SoftwareSignalSelector	O	IEnumeration	R/W	-	B	Selects which Software Signal features to control.
SoftwareSignalPulse[SoftwareSignalSelector]	O	ICommand	(R)/W	-	B	Generates a pulse signal that can be used as a software trigger.

2.12 Action Control

Contains the features related to the control of the Action command mechanism (See the [Action Control](#) chapter for details).

Table 2-12: Action Control Summary

Name	Level	Interface	Access	Unit	Visibility	Description
ActionControl	R	ICategory	R	-	G	Category that contains the Action control features.
ActionUnconditionalMode	O	IEnumeration	R/W	-	G	Enables the unconditional action command mode where action

						commands are processed even when the primary control channel is closed.
ActionDeviceKey	O	IInteger	W-O	-	G	Provides the device key that allows the device to check the validity of action commands.
ActionQueueSize	O	IInteger	R	-	G	Indicates the size of the scheduled action commands queue.
ActionSelector	O	IInteger	R/W	-	G	Selects to which Action Signal further Action settings apply.
ActionGroupMask[ActionSelector]	O	IInteger	R/W	-	G	Provides the mask that the device will use to validate the action on reception of the action protocol message.
ActionGroupKey[ActionSelector]	O	IInteger	R/W	-	G	Provides the key that the device will use to validate the action on reception of the action protocol message.

2.13 Event Control

Contains the features related to the generation of Event notifications by the device (See the [Event Control](#) chapter for details).

Table 2-13: Event Control Summary

Name	Level	Interface	Access	Unit	Visibility	Description
EventControl	R	ICategory	R	-	E	Category that contains Event control features.
EventSelector	R	IEnumeration	R/W	-	E	Selects which Event to signal to the host application.
EventNotification[EventSelector]	R	IEnumeration	R/W	-	E	Activate or deactivate the notification to the host application of the occurrence of the selected Event.

Name	Level	Interface	Access	Unit	Visibility	Description
EventFrameTriggerData	R	ICategory	R	-	E	Category that contains all the data features related to the FrameTrigger Event.
EventFrameTrigger	R	IInteger	R	-	E	Returns the unique Identifier of the FrameTrigger type of Event.
EventFrameTriggerTimestamp	R	IInteger	R	-	E	Returns the Timestamp of the FrameTrigger Event.
EventFrameTriggerFrameID	R	IInteger	R	-	E	Returns the unique Identifier of the Frame (or image) that generated the

FrameTrigger Event.

Name	Level	Interface	Access	Unit	Visibility	Description
EventExposureEndData	R	ICategory	R	-	E	Category that contains all the data features related to the ExposureEnd Event.
EventExposureEnd	R	IInteger	R	-	E	Returns the unique identifier of the ExposureEnd type of Event.
EventExposureEndTimestamp	R	IInteger	R	-	E	Returns the Timestamp of the ExposureEnd Event.
EventExposureEndFrameID	R	IInteger	R	-	E	Returns the unique Identifier of the Frame (or image) that generated the ExposureEnd Event.

Name	Level	Interface	Access	Unit	Visibility	Description
EventErrorData	R	ICategory	R	-	E	Category that contains all the data features related to the Error Event.
EventError	R	IInteger	R	-	E	Returns the unique identifier of the Error type of Event.
EventErrorTimestamp	R	IInteger	R	-	E	Returns the Timestamp of the Error Event.
EventErrorFrameID	R	IInteger	R	-	E	If applicable, returns the unique Identifier of the Frame (or image) that generated the Error Event.
EventErrorCode	R	IInteger	R	-	E	Returns an error code for the error(s) that happened.

Name	Level	Interface	Access	Unit	Visibility	Description
EventTestData	R	ICategory	R	-	E	Category that contains all the data features related to the Event Test generated using the TestEventGenerate command.
EventTest	R	IInteger	R	-	E	Returns the unique identifier of the Event Test type of event generated using the TestEventGenerate command.
EventTestTimestamp	R	IInteger	R	-	E	Returns the Timestamp of the Event Test event.

2.14 User Set Control

Contains the features related to the User Set Control to save and load the user device settings (See the [User Set Control](#) chapter for details).

Table 2-14: User Set Control Summary

Name	Level	Interface	Access	Unit	Visibility	Description
UserSetControl	R	ICategory	R	-	B	Category that contains the User Set control features.
UserSetSelector	R	IEnumeration	R/W	-	B	Selects the feature User Set to load, save or configure.
UserSetLoad[UserSetSelector]	R	ICommand	(R)/W	-	B	Loads the User Set specified by UserSetSelector to the device and makes it active.
UserSetSave[UserSetSelector]	R	ICommand	(R)/W	-	B	Save the User Set specified by UserSetSelector to the non-volatile memory of the device.
UserSetDefault	O	IEnumeration	R/W	-	B	Selects the feature User Set to load and make active by default when the device is reset.
UserSetDefaultSelector	O	IEnumeration	R/W	-	I	This feature is deprecated (See UserSetDefault).
UserSetFeatureSelector	R	IEnumeration	R/W	-	E	Selects which individual UserSet feature to control.
UserSetFeatureEnable[UserSetFeatureSelector]	R	IBoolean	R/(W)	-	E	Enables the selected feature and make it active in all the UserSets.

2.15 Sequencer Control

Contains the features related to the control of the Sequencer for features change (See the [Sequencer Control](#) chapter for details).

Table 2-15: Sequencer Control Summary

Name	Level	Interface	Access	Unit	Visibility	Description
SequencerControl	O	ICategory	R	-	E	Category for the Sequencer Control features.
SequencerMode	R	IEnumeration	R/W	-	E	Controls if the sequencer mechanism is active.
SequencerConfigurationMode	R	IEnumeration	R/W	-	E	Controls if the sequencer configuration mode is active.
SequencerFeatureSelector	R	IEnumeration	R/W	-	E	Selects which sequencer features to control.

SequencerFeatureEnable[SequencerFeatureSelector]	R	IBoolean	R/(W)	-	E	Enables the selected feature and make it active in all the sequencer sets.
SequencerSetSelector	R	IInteger	R/W	-	E	Selects the sequencer set to which further feature settings applies.
SequencerSetSave[SequencerSetSelector]	R	ICommand	(R)/W	-	E	Saves the current device state to the sequencer set selected by the SequencerSetSelector.
SequencerSetLoad[SequencerSetSelector]	R	ICommand	(R)/W	-	E	Loads the sequencer set selected by SequencerSetSelector in the device.
SequencerSetActive	O	IInteger	R	-	E	Contains the currently active sequencer set.
SequencerSetStart	R	IInteger	R/W	-	E	Sets the initial/start sequencer set, which is the first set used within a sequencer.
SequencerPathSelector[SequencerSetSelector]	R	IInteger	R/W	-	E	Selects to which branching path further path settings applies.
SequencerSetNext[SequencerSetSelector][SequencerPathSelector]	R	IInteger	R/W	-	E	Specifies the next sequencer set.
SequencerTriggerSource[SequencerSetSelector][SequencerPathSelector]	R	IEnumeration	R/W	-	E	Specifies the internal signal or physical input line to use as the sequencer trigger source.
SequencerTriggerActivation[SequencerSetSelector][SequencerPathSelector]	R	IEnumeration	R/W	-	E	Specifies the activation mode of the sequencer trigger.

2.16 File Access Control

Contains the features related to the generic file access of a device (See the [File Access Control](#) chapter for details).

Table 2-16: File Control Summary

Name	Level	Interface	Access	Unit	Visibility	Description
FileAccessControl	R	ICategory	R	-	G	Category that contains the File Access control features.
FileSelector	R	IEnumeration	R/(W)	-	G	Selects the target file in the device.
FileOperationSelector[FileSelector]	R	IEnumeration	R/W	-	G	Selects the target operation for the selected file in the device.
FileOperationExecute[FileSelector][FileOperationSelector]	R	ICommand	(R)/W	-	G	Executes the operation selected by FileOperationSelector on the

OperationSelector]						selected file.
FileOpenMode[FileSelector]	R	IEnumeration	R/(W)	-	G	Selects the access mode in which a file is opened in the device.
FileAccessBuffer	R	IRegister	R/(W)	-	G	Defines the intermediate access buffer that allows the exchange of data between the device file storage and the application.
FileAccessOffset[FileSelector][FileOperationSelector]	R	IInteger	R/(W)	B	G	Controls the Offset of the mapping between the device file storage and the FileAccessBuffer.
FileAccessLength[FileSelector][FileOperationSelector]	R	IInteger	R/W	B	G	Controls the Length of the mapping between the device file storage and the FileAccessBuffer.
FileOperationStatus[FileSelector][FileOperationSelector]	R	IEnumeration	R	-	G	Represents the file operation execution status.
FileOperationResult[FileSelector][FileOperationSelector]	R	IInteger	R	-	G	Represents the file operation result.
FileSize[FileSelector]	R	IInteger	R	B	G	Represents the size of the selected file in bytes.

2.17 Source Control

Contains the features related to the control of the multiple Source devices (See the [Source Control](#) chapter for details).

Table 2-17: Source Control Summary

Name	Level	Interface	Access	Unit	Visibility	Description
SourceControl	O	ICategory	R	-	B	Category that contains the source control features.
SourceCount	O	IInteger	R/(W)	-	B	Controls or returns the number of sources supported by the device.
SourceSelector	O	IEnumeration	R/W	-	B	Selects the source to control.
SourceIDValue[SourceSelector]	O	IInteger	R	-	E	Returns a unique Identifier value that correspond to the selected Source.

2.18 Transfer Control

Contains the features related to the control of the Transfers (See the [Transfer Control](#) chapter for details).

Table 2-18: Transfer Control Summary

Name	Level	Interface	Access	Unit	Visibility	Description
TransferControl	R	ICategory	R	-	E	Category for the data Transfer Control features.
TransferSelector	O	IEnumeration	R/(W)	-	E	Selects which stream transfers are currently controlled by the selected Transfer features.
TransferControlMode[TransferSelector]	R	IEnumeration	R/(W)	-	E	Selects the control method for the transfers.
TransferOperationMode[TransferSelector]	O	IEnumeration	R/(W)	-	E	Selects the operation mode of the transfer.
TransferBlockCount[TransferSelector]	O	IInteger	R/(W)	-	E	Specifies the number of data Blocks that the device should stream before stopping.
TransferBurstCount	O	IInteger	R/W	-	E	Number of Block(s) to transfer for each TransferBurstStart trigger.
TransferQueueMaxBlockCount[TransferSelector]	O	IInteger	R/(W)	-	E	Controls the maximum number of data blocks that can be stored in the block queue of the selected stream.
TransferQueueCurrentBlockCount[TransferSelector]	O	IInteger	R	-	E	Returns the number of Block(s) currently in the transfer queue.
TransferQueueMode[TransferSelector]	O	IEnumeration	R/(W)	-	E	Specifies the operation mode of the transfer queue.
TransferStart[TransferSelector]	O	ICommand	(R)/W	-	E	Starts the streaming of data blocks out of the device.
TransferStop[TransferSelector]	O	ICommand	(R)/W	-	E	Stops the streaming of data Block(s).
TransferAbort[TransferSelector]	O	ICommand	(R)/W	-	E	Aborts immediately the streaming of data block(s).
TransferPause[TransferSelector]	O	ICommand	(R)/W	-	G	Pauses the streaming of data Block(s).
TransferResume[TransferSelector]	O	ICommand	(R)/W	-	G	Resumes a data Blocks streaming that was previously paused by a TransferPause command.
TransferTriggerSelector[TransferSelector]	O	IEnumeration	R/W	-	G	Selects the type of transfer trigger to configure.
TransferTriggerMode[TransferSelector][TransferTriggerSelector]	R	IEnumeration	R/W	-	G	Controls if the selected trigger is active.
TransferTriggerSource[TransferTriggerSelector]	O	IEnumeration	R/W	-	G	Specifies the signal to use as the trigger source for transfers.

TransferTriggerActivation[TransferTriggerSelector]	O	IEnumeration	R/W	-	G	Specifies the activation mode of the transfer control trigger.
TransferStatusSelector[TransferSelector]	R	IEnumeration	R/W	-	G	Selects which status of the transfer module to read.
TransferStatus[TransferStatusSelector]	R	IBool	R	-	G	Reads the status of the Transfer module signal selected by TransferStatusSelector.
TransferComponentSelector[TransferSelector]	O	IEnumeration	R/W	-	G	Selects the color component for the control of the TransferStreamChannel feature.
TransferStreamChannel[TransferSelector][TransferComponentSelector]	O	IInteger	R/W	-	G	Selects the streaming channel that will be used to transfer the selected stream of data.

2.19 Scan 3D Control

Contains the features related to the control of the 3D scan features (See the [3D Scan Control](#) chapter for details).

Table 2-19: 3D Scan Control Summary

Name	Level	Interface	Access	Unit	Visibility	Description
Scan3dControl	O	ICategory	R	-	B	Category for control of 3D camera specific features.
Scan3dExtractionSelector	O	IEnumeration	R/W	-	E	Selects the 3DExtraction processing module to control (if multiple ones are present).
Scan3dExtractionSource[Scan3dExtractionSelector]	O	IEnumeration	R/W	-	E	Selects the sensor's data source region for 3D Extraction module.
Scan3dExtractionMethod[Scan3dExtractionSelector]	O	IEnumeration	R/W	-	E	Selects the method for extracting 3D from the input sensor data.
Scan3dDistanceUnit[Scan3dExtractionSelector]	O	IEnumeration	R/(W)	-	E	Specifies the unit used when delivering (calibrated) distance data.
Scan3dCoordinateSystem[Scan3dExtractionSelector]	O	IEnumeration	R/(W)	-	E	Specifies the Coordinate system to use for the device.
Scan3dOutputMode[Scan3dExtractionSelector]	O	IEnumeration	R/(W)	-	E	Controls the Calibration and data organization of the device and the coordinates transmitted.

Scan3dCoordinateSystemReference[Scan3dExtractionSelector]	O	IEnumeration	R/W	-	E	Defines coordinate system reference location.
Scan3dCoordinateSelector[Scan3dExtractionSelector]	O	IEnumeration	R/W	-	E	Selects the individual coordinates in the vectors for 3D information/transformation.
Scan3dCoordinateScale[Scan3dExtractionSelector][Scan3dCoordinateSelector]	O	IFloat	R/(W)	-	E	Scale factor when transforming a pixel from relative coordinates to world coordinates.
Scan3dCoordinateOffset[Scan3dExtractionSelector][Scan3dCoordinateSelector]	O	IFloat	R/(W)	-	E	Offset when transforming a pixel from relative coordinates to world coordinates.
Scan3dInvalidDataFlag[Scan3dExtractionSelector][Scan3dCoordinateSelector]	O	IBoolean	R/(W)	-	E	Enables the definition of a non-valid flag value in the data stream.
Scan3dInvalidDataValue[Scan3dExtractionSelector][Scan3dCoordinateSelector]	O	IFloat	R/(W)	-	E	Value which identifies a non-valid pixel if Scan3dInvalidDataFlag is enabled.
Scan3dAxisMin[Scan3dExtractionSelector][Scan3dCoordinateSelector]	O	IFloat	R	-	E	Minimum valid transmitted coordinate value of the selected Axis.
Scan3dAxisMax[Scan3dExtractionSelector][Scan3dCoordinateSelector]	O	IFloat	R	-	E	Maximum valid transmitted coordinate value of the selected Axis.
Scan3dCoordinateTransformSelector[Scan3dExtractionSelector]	O	IEnumeration	R/W	-	E	Sets the index to read/write a coordinate transform value.
Scan3dTransformValue[Scan3dExtractionSelector][Scan3dCoordinateTransformSelector]	O	IFloat	R/W	-	E	Specifies the transform value selected.
Scan3dCoordinateReferenceSelector[Scan3dExtractionSelector]	O	IEnumeration	R/W	-	E	Sets the index to read a coordinate system reference value defining the transform of a point from the current (Anchor or Transformed) system to the reference system.
Scan3dCoordinateReferenceValue[Scan3dExtractionSelector][Scan3dCoordinateReferenceSelector]	O	IFloat	R	-	E	Returns the reference value selected.
Scan3dFocalLength[RegionSelector]	O	IFloat	R	Pixel	E	Returns the focal length of the camera in pixel.
Scan3dBaseline	O	IFloat	R	m	E	Returns the baseline as the physical distance of two cameras in a stereo camera setup.

Scan3dPrincipalPointU[RegionSelector]	O	IFloat	R	Pixel	E	Returns the value of the horizontal position of the principal point, relative to the region origin, i.
Scan3dPrincipalPointV[RegionSelector]	O	IFloat	R	Pixel	E	Returns the value of the vertical position of the principal point, relative to the region origin, i.

2.20 Light Control

Contains the features related to the Lighting Control (See the Light Control chapter for details).

Table 2-20: Lighting Control Summary

Name	Level	Interface	Access	Unit	Visibility	Description
LightControl	O	ICategory	R	-	B	Category containing the Lighting control features.
LightControllerSelector	O	IEnumeration	R/W	-	B	Selects the Light Controller to configure.
LightControllerSource[LightControllerSelector]	O	IEnumeration	R/W	-	B	Selects the input source signal of the Light Controller.
LightCurrentRating[LightControllerSelector]	O	IFloat	R/W	Amp	B	Set the current rating of the lighting output.
LightVoltageRating[LightControllerSelector]	O	IFloat	R/W	Volt	B	Set the voltage rating of the lighting output.
LightBrightness[LightControllerSelector]	O	IFloat	R/W	Percent	B	Set the brightness of the lighting output in percent.
LightConnectionStatus[LightControllerSelector]	O	IEnumeration	R	-	B	Status of a light connected to the controller's output Line.
LightCurrentMeasured[LightControllerSelector]	O	IFloat	R	Amp	B	The measured current applied to the lighting.
LightVoltageMeasured[LightControllerSelector]	O	IFloat	R	Volt	B	The measured voltage applied to the lighting.

2.21 Chunk Data Control

Contains the features related to the Chunk Data Control (See the [Chunk Data Control](#) chapter for details).

Table 2-21: Chunk Data Control Summary

Name	Level	Interface	Access	Unit	Visibility	Description
ChunkDataControl	R	ICategory	R	-	E	Category that contains the Chunk Data control features.
ChunkModeActive	R	IBoolean	R/W	-	E	Activates the inclusion of Chunk data in the payload of the image.
ChunkSelector	R	IEnumeration	R/W	-	E	Selects which Chunk to enable or control.
ChunkEnable[ChunkSelector]	R	IBoolean	R/W	-	E	Enables the inclusion of the selected Chunk data in the payload of the image.
ChunkRegionSelector	O	IEnumeration	R/W	-	E	Selects which Region to retrieve data from.
ChunkRegionID	O	IEnumeration	R	-	E	Returns the Identifier of Region that the image comes from.
ChunkRegionIDValue[ChunkRegionSelector]	R	IInteger	R	-	E	Returns the unique integer Identifier value of the Region that the image comes from.
ChunkComponentSelector	O	IEnumeration	R/W	-	E	Selects the Component from which to retrieve data from.
ChunkComponentID	O	IEnumeration	R	-	E	Returns the Component Identifier of the selected Component image.
ChunkComponentIDValue[ChunkComponentSelector]	O	IInteger	R	-	E	Returns a unique Identifier value that correspond to the selected chunk Component.
ChunkImageComponent	O	IEnumeration	R	-	I	This feature is deprecated (See ChunkComponentID).
ChunkPartSelector	O	IInteger	R/W	-	I	This feature is deprecated (See ChunkComponentSelector).
ChunkImage	R	IRegister	R	-	G	Returns the entire image data included in the payload.
ChunkOffsetX	R	IInteger	R	-	E	Returns the OffsetX of the image included in the payload.
ChunkOffsetY	R	IInteger	R	-	E	Returns the OffsetY of the image included in the payload.
ChunkWidth[ChunkRegionSelector]	R	IInteger	R	-	E	Returns the Width of the image included in the payload.
ChunkHeight[ChunkRegionSelector]	R	IInteger	R	-	E	Returns the Height of the image included in the payload.
ChunkPixelFormat	R	IEnumeration	R	-	E	Returns the PixelFormat of the image included in the payload.

ChunkPixelDynamicRangeMin	R	IInteger	R	-	E	Returns the minimum value of dynamic range of the image included in the payload.
ChunkPixelDynamicRangeMax	R	IInteger	R	-	E	Returns the maximum value of dynamic range of the image included in the payload.
ChunkTimestamp	R	IInteger	R	-	E	Returns the Timestamp of the image included in the payload at the time of the FrameStart internal event.
ChunkTimestampLatchValue	R	IInteger	R	ns	E	Returns the last Timestamp latched with the TimestampLatch command.
ChunkLineStatusAll	R	IInteger	R	-	E	Returns the status of all the I/O lines at the time of the FrameStart internal event.
ChunkCounterSelector	R	IEnumeration	R/W	-	E	Selects which counter to retrieve data from.
ChunkCounterValue[ChunkCounterSelector]	R	IInteger	R	-	E	Returns the value of the selected Chunk counter at the time of the FrameStart event.
ChunkTimerSelector	R	IEnumeration	R/W	-	E	Selects which Timer to retrieve data from.
ChunkTimerValue[ChunkTimerSelector]	R	IFloat	R	us	E	Returns the value of the selected Timer at the time of the FrameStart internal event.
ChunkScanLineSelector	O	IInteger	R/W	-	E	Index for vector representation of one chunk value per line in an image.
ChunkEncoderSelector	R	IEnumeration	R/W	-	E	Selects which Encoder to retrieve data from.
ChunkEncoderValue[ChunkEncoderSelector][ChunkScanLineSelector]	R	IInteger	R	-	E	Returns the counter's value of the selected Encoder at the time of the FrameStart in area scan mode or the counter's value at the time of the LineStart selected by ChunkScanLineSelector in Linescan mode.
ChunkEncoderStatus[ChunkEncoderSelector][ChunkScanLineSelector]	O	IEnumeration	R	-	E	Returns the motion status of the selected encoder.
ChunkExposureTimeSelector	O	IEnumeration	R/W	-	E	Selects which exposure time is read by the ChunkExposureTime feature.
ChunkExposureTime[ChunkExposureTimeSelector]	R	IFloat	R	us	E	Returns the exposure time used to capture the image.
ChunkGainSelector	R	IEnumeration	R/W	-	E	Selects which Gain to return.
ChunkGain[ChunkGainSelector]	R	IFloat	R	-	E	Returns the gain used to capture the image.

ChunkBlackLevelSelector	R	IEnumeration	R/W	-	E	Selects which Black Level to return.
ChunkBlackLevel[ChunkBlackLevelSelector]	R	IFloat	R	-	E	Returns the black level used to capture the image included in the payload.
ChunkLinePitch	R	IInteger	R	B	E	Returns the LinePitch of the image included in the payload.
ChunkFrameID	R	IInteger	R	-	E	Returns the unique Identifier of the frame (or image) included in the payload.
ChunkSourceSelector	O	IEnumeration	R/W	-	E	Selects which Source to retrieve data from.
ChunkSourceID	O	IEnumeration	R	-	E	Returns the Identifier of Source that the image comes from.
ChunkSourceIDValue[ChunkSourceSelector]	R	IInteger	R	-	E	Returns the unique integer Identifier value of the Source that the image comes from.
ChunkTransferBlockID	R	IInteger	R	-	E	Returns the unique identifier of the transfer block used to transport the payload.
ChunkTransferStreamID	R	IEnumeration	R	-	E	Returns identifier of the stream that generated this block.
ChunkTransferQueueCurrentBlockCount	O	IInteger	R	-	E	Returns the current number of blocks in the transfer queue.
ChunkStreamChannelID	R	IInteger	R	-	E	Returns identifier of the stream channel used to carry the block.
ChunkSequencerSetActive	R	IInteger	R	-	E	Return the index of the active set of the running sequencer included in the payload.
ChunkScan3dDistanceUnit	O	IEnumeration	R	-	E	Returns the Distance Unit of the payload image.
ChunkScan3dOutputMode	O	IEnumeration	R	-	E	Returns the Calibrated Mode of the payload image.
ChunkScan3dCoordinateSystem	O	IEnumeration	R	-	E	Returns the Coordinate System of the image included in the payload.
ChunkScan3dCoordinateSystemReference	O	IEnumeration	R	-	E	Returns the Coordinate System Position of the image included in the payload.
ChunkScan3dCoordinateSelector	O	IEnumeration	R/W	-	E	Selects which Coordinate to retrieve data from.
ChunkScan3dCoordinateScale[ChunkScan3dCoordinateSelector]	O	IFloat	R	-	E	Returns the Scale for the selected coordinate axis of the image included in the payload.
ChunkScan3dCoordinateOffset[ChunkScan3dCoordinateSelector]	O	IFloat	R	-	E	Returns the Offset for the selected coordinate axis of the image included in the payload.

ChunkScan3dInvalidDataFlag[ChunkScan3dCoordinateSelector]	O	IBoolean	R	-	E	Returns if a specific non-valid data flag is used in the data stream.
ChunkScan3dInvalidDataValue[ChunkScan3dCoordinateSelector]	O	IFloat	R	-	E	Returns the Invalid Data Value used for the image included in the payload.
ChunkScan3dAxisMin[ChunkScan3dCoordinateSelector]	O	IFloat	R	-	E	Returns the Minimum Axis value for the selected coordinate axis of the image included in the payload.
ChunkScan3dAxisMax[ChunkScan3dCoordinateSelector]	O	IFloat	R	-	E	Returns the Maximum Axis value for the selected coordinate axis of the image included in the payload.
ChunkScan3dCoordinateTransformSelector	O	IEnumeration	R/W	-	E	Selector for transform values.
ChunkScan3dTransformValue[ChunkScan3dCoordinateTransformSelector]	O	IFloat	R	-	E	Returns the transform value.
ChunkScan3dCoordinateReferenceSelector	O	IEnumeration	R/W	-	E	Selector to read a coordinate system reference value defining the transform of a point from one system to the other.
ChunkScan3dCoordinateReferenceValue[ChunkScan3dCoordinateReferenceSelector]	O	IFloat	R	-	E	Returns the value of a position or pose coordinate for the anchor or transformed coordinate systems relative to the reference point.
ChunkScan3dFocalLength	O	IFloat	R	Pixel	E	Returns the focal length of the camera in pixel.
ChunkScan3dBaseline	O	IFloat	R	m	E	Returns the baseline as the physical distance of two cameras in a stereo camera setup.
ChunkScan3dPrincipalPointU	O	IFloat	R	Pixel	E	Returns the value of this feature gives the horizontal position of the principal point, relative to the region origin, i.
ChunkScan3dPrincipalPointV	O	IFloat	R	Pixel	E	Returns the value of this feature gives the vertical position of the principal point, relative to the region origin, i.

2.22 Test Control

Contains the features related to the control of the test features (See the [Test Control](#) chapter for details).

Table 2-22: Test Control Summary

Name	Level	Interface	Access	Unit	Visibility	Description
TestControl	R	ICategory	R	-	G	Category for Test Control features.
TestPendingAck	O	IInteger	R/W	ms	G	Tests the device's pending acknowledge feature.
TestEventGenerate	O	ICommand	(R)/W	-	G	Generates a Test Event.
TestPayloadFormatMode	R	IEnumeration	R/W	-	G	This feature allows setting a device in test mode and to output a specific payload format for validation of data streaming.

2.23 GenICam Control

Contains the features related to GenICam control and access (See the [GenICam Control](#) chapter for details).

Table 2-23: GenICam Control Summary

Name	Level	Interface	Access	Unit	Visibility	Description
Root	M	ICategory	R	-	G	Provides the Root of the GenICam features tree.
Device	M	IPort	R/W	-	I	Provides the default GenICam port of the Device.

2.24 Transport Layer Control

Contains the features related to the Transport Layer Control (See the [Transport Layer Control](#) chapter for details).

Table 2-24: Transport Layer Control Summary

Name	Level	Interface	Access	Unit	Visibility	Description
TransportLayerControl	R	ICategory	R	-	B	Category that contains the transport Layer control features.
TLParamsLocked	M	IInteger	R/W	-	I	Used by the Transport Layer to prevent critical features from changing during acquisition.
TLParamsLockedSelector	O	IEnumeration	R/(W)	-	G	Selects the type of feature for which the locking behavior will be configured.

TLParamsLockedState[TLParamsLockedSelector]	O	IBoolean	R/(W)	-	G	Controls if the selected parameters are locked during acquisition.
PayloadSize	R	IInteger	R	B	E	Provides the number of bytes transferred for each image or chunk on the stream channel.
DeviceTapGeometry	R	IEnumeration	R/(W)	-	E	This device tap geometry feature describes the geometrical properties characterizing the taps of a camera as presented at the output of the device.

Name	Level	Interface	Access	Unit	Visibility	Description
PtpControl	O	ICategory	R	-	E	Category that contains the features related to the Precision Time Protocol (PTP) of the device.
PtpEnable	O	IBoolean	R/W	-	E	Enables the Precision Time Protocol (PTP).
PtpClockAccuracy	O	IEnumeration	R	-	E	Indicates the expected accuracy of the device PTP clock when it is the grandmaster, or in the event it becomes the grandmaster.
PtpDataSetLatch	O	ICommand	W	-	E	Latches the current values from the device's PTP clock data set.
PtpStatus	O	IEnumeration	R	-	E	Returns the latched state of the PTP clock.
PtpServoStatus	O	IEnumeration	R	-	E	Returns the latched state of the clock servo.
PtpOffsetFromMaster	O	IInteger	R	ns	E	Returns the latched offset from the PTP master clock in nanoseconds.
PtpClockId	O	IInteger	R	-	E	Returns the latched clock ID of the PTP device.
PtpParentClockId	O	IInteger	R	-	E	Returns the latched parent clock ID of the PTP device.
PtpGrandmasterClockID	O	IInteger	R	-	E	Returns the latched grandmaster clock ID of the PTP device.

Name	Level	Interface	Access	Unit	Visibility	Description
------	-------	-----------	--------	------	------------	-------------

GigEVision	O	ICategory	R	-	B	Category that contains the features pertaining to the GigE Vision transport layer of the device.
GevVersionMajor	R	IInteger	R	-	I	This feature is deprecated (See DeviceTLVersionMajor).
GevVersionMinor	R	IInteger	R	-	I	This feature is deprecated (See DeviceTLVersionMinor).
GevDeviceModeIsBigEndian	O	IBoolean	R	-	I	This feature is deprecated (See DeviceRegistersEndianness).
GevDeviceClass	O	IEnumeration	R	-	I	This feature is deprecated (See DeviceType).
GevDeviceModeCharacterSet	O	IEnumeration	R	-	I	This feature is deprecated (See DeviceCharacterSet).
GevPhysicalLinkConfiguration	O	IEnumeration	R/W	-	E	Controls the principal physical link configuration to use on next restart/power-up of the device.
GevCurrentPhysicalLinkConfiguration	O	IEnumeration	R	-	E	Indicates the current physical link configuration of the device.
GevActiveLinkCount	O	IInteger	R	-	I	Indicates the current number of active logical links.
GevSupportedOptionSelector	O	IEnumeration	R/W	-	E	Selects the GEV option to interrogate for existing support.
GevSupportedOption[GevSupportedOptionSelector]	O	IBoolean	R	-	E	Returns if the selected GEV option is supported.
GevInterfaceSelector	O	IInteger	R/W	-	B	Selects which logical link to control.
GevLinkSpeed[GevInterfaceSelector]	O	IInteger	R	Mbs	I	This feature is deprecated (See DeviceLinkSpeed).
GevMACAddress[GevInterfaceSelector]	O	IInteger	R	-	B	MAC address of the logical link.
GevPAUSEFrameReception[GevInterfaceSelector]	O	IBoolean	R/(W)	-	E	Controls whether incoming PAUSE Frames are handled on the given logical link.
GevPAUSEFrameTransmission[GevInterfaceSelector]	O	IBoolean	R/(W)	-	E	Controls whether PAUSE Frames can be generated on the given logical link.
GevCurrentIPConfigurationLLA[GevInterfaceSelector]	O	IBoolean	R/W	-	B	Controls whether the Link Local Address IP configuration scheme is activated on the given logical link.
GevCurrentIPConfigurationDHCP[GevInterfaceSelector]	O	IBoolean	R/W	-	B	Controls whether the DHCP IP configuration scheme is activated on the given logical link.
GevCurrentIPConfigurationPersistentIP[GevInterfaceSelector]	O	IBoolean	R/W	-	B	Controls whether the PersistentIP configuration scheme is activated on the given logical link.

GevCurrentIPAddress[GevInterfaceSelector]	O	IInteger	R	-	B	Reports the IP address for the given logical link.
GevCurrentSubnetMask[GevInterfaceSelector]	O	IInteger	R	-	B	Reports the subnet mask of the given logical link.
GevCurrentDefaultGateway[GevInterfaceSelector]	O	IInteger	R	-	B	Reports the default gateway IP address of the given logical link.
GevIPConfigurationStatus[GevInterfaceSelector]	O	IEnumeration	R	-	B	Reports the current IP configuration status.
GevFirstURL	O	IString	R	-	I	Indicates the first URL to the GenICam XML device description file.
GevSecondURL	O	IString	R	-	I	Indicates the second URL to the GenICam XML device description file.
GevNumberOfInterfaces	O	IInteger	R	-	I	This feature is deprecated (See DeviceLinkSelector).
GevPersistentIPAddress[GevInterfaceSelector]	O	IInteger	R/W	-	B	Controls the Persistent IP address for this logical link.
GevPersistentSubnetMask[GevInterfaceSelector]	O	IInteger	R/W	-	B	Controls the Persistent subnet mask associated with the Persistent IP address on this logical link.
GevPersistentDefaultGateway[GevInterfaceSelector]	O	IInteger	R/W	-	B	Controls the persistent default gateway for this logical link.
GevMessageChannelCount	O	IInteger	R	-	I	This feature is deprecated (See DeviceEventChannelCount).
GevStreamChannelCount	O	IInteger	R	-	I	This feature is deprecated (See DeviceStreamChannelCount).
GevHeartbeatTimeout	O	IInteger	R/W	ms	G	This feature is deprecated (See DeviceLinkHeartbeatTimeout).
GevTimestampTickFrequency	O	IInteger	R	Hz	I	This feature is deprecated (See the increment of the TimestampLatchValue feature).
GevTimestampControlLatch	O	ICommand	W	-	I	This feature is deprecated (See TimestampLatch).
GevTimestampControlReset	O	ICommand	W	-	I	This feature is deprecated (See TimestampReset).
GevTimestampValue	O	IInteger	R	-	I	This feature is deprecated (See TimestampLatchValue).
GevDiscoveryAckDelay	O	IInteger	R/(W)	ms	E	Indicates the maximum randomized delay the device will wait to acknowledge a discovery command.
GevIEEE1588	O	IBoolean	R/W	-	I	This feature is deprecated (See PtpEnable).

GevIEEE1588ClockAccuracy	O	IEnumeration	R/(W)	-	I	This feature is deprecated (See PtpClockAccuracy).
GevIEEE1588Status	O	IEnumeration	R	-	I	This feature is deprecated (See PtpStatus).
GevGVCPEExtendedStatusCodesSelector	O	IEnumeration	R/W	-	G	Selects the GigE Vision version to control extended status codes for.
GevGVCPEExtendedStatusCodes[GevGVCPEExtendedStatusCodesSelector]	O	IBoolean	R/W	-	G	Enables the generation of extended status codes.
GevGVCPPendingAck	O	IBoolean	R/W	-	G	Enables the generation of PENDING_ACK.
GevGVCPPHeartbeatDisable	O	IBoolean	R/W	-	I	This feature is deprecated (See DeviceLinkHeartbeatMode).
GevGVCPPendingTimeout	O	IInteger	R	-	I	This feature is deprecated (See DeviceLinkCommandTimeout).
GevPrimaryApplicationSwitchoverKey	O	IInteger	W-O	-	G	Controls the key to use to authenticate primary application switchover requests.
GevGVSPExtendedIDMode	O	IEnumeration	R/(W)	-	E	Enables the extended IDs mode.
GevCCP	O	IEnumeration	R/W	-	G	Controls the device access privilege of an application.
GevPrimaryApplicationSocket	O	IInteger	R	-	G	Returns the UDP source port of the primary application.
GevPrimaryApplicationIPAddress	O	IInteger	R	-	G	Returns the address of the primary application.
GevMCPHostPort	O	IInteger	R/W	-	G	Controls the port to which the device must send messages.
GevMCDA	O	IInteger	R/W	-	G	Controls the destination IP address for the message channel.
GevMCTT	O	IInteger	R/W	ms	G	Provides the transmission timeout value in milliseconds.
GevMCRC	O	IInteger	R/W	-	G	Controls the number of retransmissions allowed when a message channel message times out.
GevMCSP	O	IInteger	R	-	G	This feature indicates the source port for the message channel.
GevStreamChannelSelector	O	IInteger	R/W	-	E	Selects the stream channel to control.
GevSCCFGPacketResendDestination[GevStreamChannelSelector]	O	IBoolean	R/W	-	G	Enables the alternate IP destination for stream packets resent due to a packet resend request.
GevSCCFGAllInTransmission[GevStreamChannelSelector]	O	IBoolean	R/W	-	G	Enables the selected GVSP transmitter to use the single packet per data block All-in Transmission mode.
GevSCCFGUnconditionalStreaming[GevStreamChannelSelector]	O	IBoolean	R/W	-	G	Enables the camera to continue to stream, for this stream channel, if its control channel is closed or regardless of the reception of any ICMP

						messages (such as destination unreachable messages).
GevSCCFGExtendedChunkData[GevStreamChannelSelector]	O	IBoolean	R/W	-	G	Enables cameras to use the extended chunk data payload type for this stream channel.
GevSCPDDirection[GevStreamChannelSelector]	O	IEnumeration	R	-	I	This feature is deprecated (See DeviceStreamChannelType).
GevSCPIInterfaceIndex[GevStreamChannelSelector]	O	IInteger	R/(W)	-	G	Index of the logical link to use.
GevSCPHostPort[GevStreamChannelSelector]	O	IInteger	R/W	-	G	Controls the port of the selected channel to which a GVSP transmitter must send data stream or the port from which a GVSP receiver may receive data stream.
GevSCPSFireTestPacket[GevStreamChannelSelector]	O	IBoolean	R/W	-	G	Sends a test packet.
GevSCPSDoNotFragment[GevStreamChannelSelector]	O	IBoolean	R/W	-	G	The state of this feature is copied into the "do not fragment" bit of IP header of each stream packet.
GevSCPSBigEndian[GevStreamChannelSelector]	O	IBoolean	R/W	-	I	This feature is deprecated (See DeviceStreamChannelEndianness).
GevSCPSPacketSize[GevStreamChannelSelector]	R	IInteger	R/(W)	B	E	This GigE Vision specific feature corresponds to DeviceStreamChannelPacketSize and should be kept in sync with it.
GevSCPD[GevStreamChannelSelector]	R	IInteger	R/W		E	Controls the delay (in GEV timestamp counter unit) to insert between each packet for this stream channel.
GevSCDA[GevStreamChannelSelector]	O	IInteger	R/W	-	G	Controls the destination IP address of the selected stream channel to which a GVSP transmitter must send data stream or the destination IP address from which a GVSP receiver may receive data stream.
GevSCSP[GevStreamChannelSelector]	O	IInteger	R	-	G	Indicates the source port of the stream channel.
GevSCZoneCount[GevStreamChannelSelector]	O	IInteger	R	-	G	Reports the number of zones per block transmitted on the selected stream channel.
GevSCZoneDirectionAll[GevStreamChannelSelector]	O	IInteger	R	-	G	Reports the transmission direction of each zone transmitted on the selected stream channel.
GevSCZoneConfigurationLock[GevStreamChannelSelector]	O	IBoolean	R/W	-	G	Controls whether the selected stream channel multi-zone configuration is locked.

Name	Level	Interface	Access	Unit	Visibility	Description
NetworkStatistics	O	ICategory	R	-	G	Category that contains statistics pertaining to various modules of the GigE Vision transport layer.

Name	Level	Interface	Access	Unit	Visibility	Description
oMACControlFunctionEntity	O	ICategory	R	-	G	Category that contains statistics pertaining to the MAC control PAUSE function of the device.
aPAUSEMACCtrlFramesTransmitted[GevInterfaceSelector]	O	IInteger	R	-	G	Reports the number of transmitted PAUSE frames.
aPAUSEMACCtrlFramesReceived[GevInterfaceSelector]	O	IInteger	R	-	G	Reports the number of received PAUSE frames.

Name	Level	Interface	Access	Unit	Visibility	Description
CameraLink	O	ICategory	R	-	B	Category that contains the features pertaining to the Camera Link transport layer of the device.
ClConfiguration	R	IEnumeration	R/(W)	-	B	This Camera Link specific feature describes the configuration used by the camera.
ClTimeSlotsCount	O	IEnumeration	R/(W)	-	E	This Camera Link specific feature describes the time multiplexing of the camera link connection to transfer more than the configuration allows, in one single clock.

CoaXPress

Name	Level	Interface	Access	Unit	Visibility	Description
CoaXPress	O	ICategory	R	-	B	Category that contains the features pertaining to the CoaXPress transport layer of the device.

CxpLinkConfigurationStatus	R	IEnumeration	R	-	B	This feature indicates the current and active Link configuration used by the Device.
CxpLinkConfigurationPreferred	R	IEnumeration	R	-	E	Provides the Link configuration that allows the Transmitter Device to operate in its default mode.
CxpLinkConfiguration	R	IEnumeration	R/W	-	B	This feature allows specifying the Link configuration for the communication between the Receiver and Transmitter Device.
CxpConnectionSelector	R	IInteger	R/W	-	E	Selects the CoaXPress physical connection to control.
CxpConnectionTestMode[CxpConnectionSelector]	R	IEnumeration	R/W	-	E	Enables the test mode for an individual physical connection of the Device.
CxpConnectionTestErrorCount[CxpConnectionSelector]	R	IInteger	R/W	-	E	Reports the current connection error count for test packets received by the device on the connection selected by CxpConnectionSelector.
CxpConnectionTestPacketCount[CxpConnectionSelector]	R	IInteger	R/W	-	E	Reports the current count for test packets received by the device on the connection selected by CxpConnectionSelector.
CxpPoCxpAuto	O	ICommand	W	-	E	Activate automatic control of the Power over CoaXPress (PoCXP) for the Link.
CxpPoCxpTurnOff	O	ICommand	W	-	E	Disable Power over CoaXPress (PoCXP) for the Link.
CxpPoCxpTripReset	O	ICommand	W	-	E	Reset the Power over CoaXPress (PoCXP) Link after an over-current trip on the Device connection(s).
CxpPoCxpStatus	O	IEnumeration	R	-	E	Returns the Power over CoaXPress (PoCXP) status of the Device.

3 Device Control

Device control features provides general information and control for the device (camera) and its sensor. This is mainly used to identify the device during the enumeration process and to obtain information about the sensor resolution. Other information and controls pertaining to the general state of the device are also included in this category.

3.1 DeviceControl

Name	DeviceControl
Category	Root
Level	Recommended
Interface	ICategory
Access	Read
Unit	-
Visibility	Beginner
Values	-

Category for device information and control.

3.2 DeviceType

Name	DeviceType
Category	DeviceControl
Level	Optional
Interface	IEnumeration
Access	Read
Unit	-
Visibility	Guru
Values	Transmitter Receiver Transceiver Peripheral

Returns the device type.

Possible values are:

- **Transmitter:** Data stream transmitter device.
- **Receiver:** Data stream receiver device.
- **Transceiver:** Data stream receiver and transmitter device.
- **Peripheral:** Controllable device (with no data stream handling).

3.3 DeviceScanType

Name	DeviceScanType
Category	DeviceControl
Level	Recommended
Interface	IEnumeration
Access	Read/(Write)
Unit	-
Visibility	Expert
Values	Areascan Linescan Areascan3D Linescan3D

Scan type of the sensor of the device.

Typically, this feature is not writable. But some cameras might allow switching between linescan and areascan.

Possible values are:

- **Areascan**: 2D sensor.
- **Linescan**: 1D sensor.
- **Areascan3D**: device outputs 2D range image.
- **Linescan3D**: device outputs 1D range image.

3.4 DeviceVendorName

Name	DeviceVendorName
Category	DeviceControl
Level	Recommended
Interface	IString
Access	Read
Unit	-
Visibility	Beginner
Values	Any NULL-terminated string

Name of the manufacturer of the device.

3.5 DeviceModelName

Name	DeviceModelName
Category	DeviceControl
Level	Recommended
Interface	IString
Access	Read
Unit	-
Visibility	Beginner
Values	Any NULL-terminated string

Model of the device.

3.6 DeviceFamilyName

Name	DeviceFamilyName
Category	DeviceControl
Level	Optional
Interface	IString
Access	Read
Unit	-
Visibility	Beginner
Values	Any NULL-terminated string

Identifier of the product family of the device.

3.7 DeviceManufacturerInfo

Name	DeviceManufacturerInfo
Category	DeviceControl
Level	Recommended
Interface	IString
Access	Read
Unit	-
Visibility	Beginner
Values	Any NULL-terminated string

Manufacturer information about the device.

3.8 DeviceVersion

Name	DeviceVersion
Category	DeviceControl
Level	Recommended
Interface	IString
Access	Read
Unit	-
Visibility	Beginner
Values	Any NULL-terminated string

Version of the device.

3.9 DeviceFirmwareVersion

Name	DeviceFirmwareVersion
Category	DeviceControl
Level	Recommended
Interface	IString
Access	Read
Unit	-
Visibility	Beginner
Values	Any NULL-terminated string

Version of the firmware in the device.

3.10 DeviceSerialNumber

Name	DeviceSerialNumber
Category	DeviceControl
Level	Recommended
Interface	IString
Access	Read
Unit	-
Visibility	Expert
Values	Any NULL-terminated string

Device's serial number. This string is a unique identifier of the device.

3.11 DeviceID (Deprecated)

Name	DeviceID
Category	DeviceControl
Level	Recommended
Interface	IString
Access	Read
Unit	-
Visibility	Invisible
Values	Any NULL-terminated string

This feature is deprecated (See DeviceSerialNumber). It was representing the Device unique identifier (serial number).

To help backward compatibility, this feature can be included as Invisible in the device's XML.

3.12 DeviceUserID

Name	DeviceUserID
Category	DeviceControl
Level	Optional
Interface	IString
Access	Read/Write
Unit	-
Visibility	Beginner
Values	Any NULL-terminated string

User-programmable device identifier.

When this feature is present, it must be writable and should be persistent.

The recommended factory default value is an empty string.

3.13 DeviceSFNCVersionMajor

Name	DeviceSFNCVersionMajor
Category	DeviceControl
Level	Recommended
Interface	IInteger
Access	Read
Unit	-

Visibility	Beginner
Values	>0

Major version of the Standard Features Naming Convention that was used to create the device's GenICam XML.

3.14 DeviceSFNCVersionMinor

Name	DeviceSFNCVersionMinor
Category	DeviceControl
Level	Recommended
Interface	IInteger
Access	Read
Unit	-
Visibility	Beginner
Values	≥ 0

Minor version of the Standard Features Naming Convention that was used to create the device's GenICam XML.

3.15 DeviceSFNCVersionSubMinor

Name	DeviceSFNCVersionSubMinor
Category	DeviceControl
Level	Recommended
Interface	IInteger
Access	Read
Unit	-
Visibility	Beginner
Values	≥ 0

Sub minor version of Standard Features Naming Convention that was used to create the device's GenICam XML.

3.16 DeviceManifestEntrySelector

Name	DeviceManifestEntrySelector
-------------	-----------------------------

Category	DeviceControl
Level	Optional
Interface	IInteger
Access	Read/Write
Unit	-
Visibility	Guru
Values	≥ 1

Selects the manifest entry to reference.

3.17 DeviceManifestXMLMajorVersion

Name	DeviceManifestXMLMajorVersion [DeviceManifestEntrySelector]
Category	DeviceControl
Level	Optional
Interface	IInteger
Access	Read
Unit	-
Visibility	Guru
Values	≥ 0

Indicates the major version number of the GenICam XML file of the selected manifest entry.

3.18 DeviceManifestXMLMinorVersion

Name	DeviceManifestXMLMinorVersion [DeviceManifestEntrySelector]
Category	DeviceControl
Level	Optional
Interface	IInteger
Access	Read
Unit	-
Visibility	Guru
Values	≥ 0

Indicates the minor version number of the GenICam XML file of the selected manifest entry.

3.19 DeviceManifestXMLSubMinorVersion

Name	DeviceManifestXMLSubMinorVersion [DeviceManifestEntrySelector]
Category	DeviceControl
Level	Optional
Interface	IInteger
Access	Read
Unit	-
Visibility	Guru
Values	≥ 0

Indicates the subminor version number of the GenICam XML file of the selected manifest entry.

3.20 DeviceManifestSchemaMajorVersion

Name	DeviceManifestSchemaMajorVersion [DeviceManifestEntrySelector]
Category	DeviceControl
Level	Optional
Interface	IInteger
Access	Read
Unit	-
Visibility	Guru
Values	≥ 0

Indicates the major version number of the schema file of the selected manifest entry.

3.21 DeviceManifestSchemaMinorVersion

Name	DeviceManifestSchemaMinorVersion [DeviceManifestEntrySelector]
Category	DeviceControl
Level	Optional
Interface	IInteger
Access	Read
Unit	-
Visibility	Guru
Values	≥ 0

Indicates the minor version number of the schema file of the selected manifest entry.

3.22 DeviceManifestPrimaryURL

Name	DeviceManifestPrimaryURL [DeviceManifestEntrySelector]
Category	DeviceControl
Level	Optional
Interface	IString
Access	Read
Unit	-
Visibility	Guru
Values	-

Indicates the first URL to the GenICam XML device description file of the selected manifest entry.

3.23 DeviceManifestSecondaryURL

Name	DeviceManifestSecondaryURL [DeviceManifestEntrySelector]
Category	DeviceControl
Level	Optional
Interface	IString
Access	Read
Unit	-
Visibility	Guru
Values	-

Indicates the second URL to the GenICam XML device description file of the selected manifest entry.

3.24 DeviceTLType

Name	DeviceTLType
Category	DeviceControl
Level	Recommended
Interface	IEnumeration
Access	Read
Unit	-

Visibility	Beginner
Values	GigEVision CameraLink CameraLinkHS CoaXPress USB3Vision Custom

Transport Layer type of the device.

Possible values are:

- **GigEVision:** GigE Vision.
- **CameraLink:** Camera Link.
- **CameraLinkHS:** Camera Link High Speed.
- **CoaXPress:** CoaXPress.
- **USB3Vision:** USB3 Vision.
- **Custom:** Custom Transport Layer.

3.25 DeviceTLVersionMajor

Name	DeviceTLVersionMajor
Category	DeviceControl
Level	Recommended
Interface	IInteger
Access	Read
Unit	-
Visibility	Beginner
Values	>0

Major version of the Transport Layer of the device.

3.26 DeviceTLVersionMinor

Name	DeviceTLVersionMinor
Category	DeviceControl
Level	Recommended
Interface	IInteger
Access	Read

Unit	-
Visibility	Beginner
Values	≥ 0

Minor version of the Transport Layer of the device.

3.27 DeviceTLVersionSubMinor

Name	DeviceTLVersionSubMinor
Category	DeviceControl
Level	Recommended
Interface	IInteger
Access	Read
Unit	-
Visibility	Beginner
Values	≥ 0

Sub minor version of the Transport Layer of the device.

3.28 DeviceGenCPVersionMajor

Name	DeviceGenCPVersionMajor
Category	DeviceControl
Level	Recommended
Interface	IInteger
Access	Read
Unit	-
Visibility	Beginner
Values	> 0

Major version of the GenCP protocol supported by the device.

3.29 DeviceGenCPVersionMinor

Name	DeviceGenCPVersionMinor
Category	DeviceControl
Level	Recommended
Interface	IInteger

Access	Read
Unit	-
Visibility	Beginner
Values	≥ 0

Minor version of the GenCP protocol supported by the device.

3.30 DeviceMaxThroughput

Name	DeviceMaxThroughput
Category	DeviceControl
Level	Optional
Interface	IInteger
Access	Read
Unit	Bps
Visibility	Expert
Values	> 0

Maximum bandwidth of the data that can be streamed out of the device. This can be used to estimate if the physical connection(s) can sustain transfer of free-running images from the camera at its maximum speed.

3.31 DeviceConnectionSelector

Name	DeviceConnectionSelector
Category	DeviceControl
Level	Recommended
Interface	IInteger
Access	Read/(Write)
Unit	-
Visibility	Beginner
Values	≥ 0

Selects which Connection of the device to control.

3.32 DeviceConnectionSpeed

Name	DeviceConnectionSpeed [DeviceConnectionSelector]
Category	DeviceControl

Level	Optional
Interface	IInteger
Access	Read
Unit	Bps
Visibility	Expert
Values	>0

Indicates the speed of transmission of the specified Connection

3.33 DeviceConnectionStatus

Name	DeviceConnectionStatus [DeviceConnectionSelector]
Category	DeviceControl
Level	Optional
Interface	IEnumeration
Access	Read
Unit	-
Visibility	Expert
Values	Active Inactive

Indicates the status of the specified Connection.

Possible values are:

- **Active:** Connection is in use.
- **Inactive:** Connection is not in use.

3.34 DeviceLinkSelector

Name	DeviceLinkSelector
Category	DeviceControl
Level	Recommended
Interface	IInteger
Access	Read/(Write)
Unit	-
Visibility	Beginner
Values	≥0

Selects which Link of the device to control.

Generally, a device has only one Link that can be composed of one or many connections. But if there are many, this selector can be used to target a particular Link of the device with certain features.

3.35 DeviceLinkSpeed

Name	DeviceLinkSpeed [DeviceLinkSelector]
Category	DeviceControl
Level	Optional
Interface	IInteger
Access	Read
Unit	Bbs
Visibility	Expert
Values	≥ 0

Indicates the speed of transmission negotiated on the specified Link.

Note that this represents the total speed of all the connections of the Link.

3.36 DeviceLinkThroughputLimitMode

Name	DeviceLinkThroughputLimitMode [DeviceLinkSelector]
Category	DeviceControl
Level	Recommended
Interface	IEnumeration
Access	Read/Write
Unit	-
Visibility	Expert
Values	On Off

Controls if the **DeviceLinkThroughputLimit** is active. When disabled, lower level TL specific features are expected to control the throughput. When enabled, **DeviceLinkThroughputLimit** controls the overall throughput.

Possible values are:

- **On:** Enables the **DeviceLinkThroughputLimit** feature.
- **Off:** Disables the **DeviceLinkThroughputLimit** feature.

3.37 DeviceLinkThroughputLimit

Name	DeviceLinkThroughputLimit [DeviceLinkSelector]
Category	DeviceControl
Level	Recommended
Interface	IInteger
Access	Read/(Write)
Unit	Bps
Visibility	Expert
Values	≥ 0

Limits the maximum bandwidth of the data that will be streamed out by the device on the selected Link. If necessary, delays will be uniformly inserted between transport layer packets in order to control the peak bandwidth.

If the device uses many connections to transmit the data, the feature represents the sum of all the traffic and the bandwidth should be distributed uniformly on the various connections.

Any Transport Layer specific bandwidth controls should be kept in sync with this control as much as possible.

3.38 DeviceLinkConnectionCount

Name	DeviceLinkConnectionCount [DeviceLinkSelector]
Category	DeviceControl
Level	Optional
Interface	IInteger
Access	Read
Unit	-
Visibility	Beginner
Values	≥ 0

Returns the number of physical connection of the device used by a particular Link.

3.39 DeviceLinkHeartbeatMode

Name	DeviceLinkHeartbeatMode [DeviceLinkSelector]
-------------	---

Category	DeviceControl
Level	Optional
Interface	IEnumeration
Access	Read/Write
Unit	-
Visibility	Expert
Values	On Off

Activate or deactivate the Link's heartbeat.

Possible values are:

- **Off:** Disables the Link heartbeat.
- **On:** Enables the Link heartbeat.

3.40 DeviceLinkHeartbeatTimeout

Name	DeviceLinkHeartbeatTimeout [DeviceLinkSelector]
Category	DeviceControl
Level	Optional
Interface	IFloat
Access	Read/Write
Unit	us
Visibility	Guru
Values	>0

Controls the current heartbeat timeout of the specific Link.

3.41 DeviceLinkCommandTimeout

Name	DeviceLinkCommandTimeout [DeviceLinkSelector]
Category	DeviceControl
Level	Optional
Interface	IFloat
Access	Read
Unit	us
Visibility	Guru

Values	>0
---------------	----

Indicates the command timeout of the specified Link. This corresponds to the maximum response time of the device for a command sent on that link.

Note that some Transport Layer Protocols might support that the device responds (within the DeviceLinkCommandTimeout period) that the completion of a particularly long command will be delayed by a specific amount of time. This notion is generally known as a "Pending Acknowledge" command.

3.42 DeviceStreamChannelCount

Name	DeviceStreamChannelCount
Category	DeviceControl
Level	Optional
Interface	IInteger
Access	Read
Unit	-
Visibility	Expert
Values	≥0

Indicates the number of streaming channels supported by the device.

3.43 DeviceStreamChannelSelector

Name	DeviceStreamChannelSelector
Category	DeviceControl
Level	Optional
Interface	IInteger
Access	Read/Write
Unit	-
Visibility	Expert
Values	≥0

Selects the stream channel to control.

3.44 DeviceStreamChannelType

Name	DeviceStreamChannelType [DeviceStreamChannelSelector]
Category	DeviceControl

Level	Optional
Interface	IEnumeration
Access	Read
Unit	-
Visibility	Guru
Values	Transmitter Receiver

Reports the type of the stream channel.

Possible values are:

- **Transmitter:** Data stream transmitter channel.
- **Receiver:** Data stream receiver channel.

3.45 DeviceStreamChannelLink

Name	DeviceStreamChannelLink [DeviceStreamChannelSelector]
Category	DeviceControl
Level	Optional
Interface	IInteger
Access	Read/(Write)
Unit	-
Visibility	Guru
Values	≥ 0

Index of device's Link to use for streaming the specified stream channel.

3.46 DeviceStreamChannelEndianness

Name	DeviceStreamChannelEndianness [DeviceStreamChannelSelector]
Category	DeviceControl
Level	Optional
Interface	IEnumeration
Access	Read/(Write)
Unit	-
Visibility	Guru
Values	Big

	Little
--	--------

Endianness of multi-byte pixel data for this stream.

Possible values are:

- **Big:** Stream channel data is big Endian.
- **Little:** Stream channel data is little Endian.

3.47 DeviceStreamChannelPacketSize

Name	DeviceStreamChannelPacketSize [DeviceStreamChannelSelector]
Category	DeviceControl
Level	Recommended
Interface	IInteger
Access	Read/(Write)
Unit	B
Visibility	Expert
Values	>0

Specifies the stream packet size, in bytes, to send on the selected channel for a Transmitter or specifies the maximum packet size supported by a receiver.

3.48 DeviceEventChannelCount

Name	DeviceEventChannelCount
Category	DeviceControl
Level	Optional
Interface	IInteger
Access	Read
Unit	-
Visibility	Expert
Values	≥0

Indicates the number of event channels supported by the device.

3.49 DeviceMessageChannelCount (Deprecated)

Name	DeviceMessageChannelCount
Category	DeviceControl

Level	Optional
Interface	IInteger
Access	Read
Unit	-
Visibility	Invisible
Values	≥ 0

This feature is deprecated (See DeviceEventChannelCount). It indicates the number of message/event channels supported by the device.

3.50 DeviceCharacterSet

Name	DeviceCharacterSet
Category	DeviceControl
Level	Optional
Interface	IEnumeration
Access	Read
Unit	-
Visibility	Guru
Values	UTF8 ASCII

Character set used by the strings of the device's bootstrap registers.

Possible values are:

- **UTF8**: Device use UTF8 character set.
- **ASCII**: Device use ASCII character set.

3.51 DeviceReset

Name	DeviceReset
Category	DeviceControl
Level	Recommended
Interface	ICommand
Access	Write
Unit	-
Visibility	Guru
Values	-

Resets the device to its power up state. After reset, the device must be rediscovered.

Note that some Transport Layers require the acknowledgement of the DeviceReset command before starting the actual reset of the device.

3.52 DeviceIndicatorMode

Name	DeviceIndicatorMode
Category	DeviceControl
Level	Optional
Interface	IEnumeration
Access	Read/Write
Unit	-
Visibility	Expert
Values	Inactive Active ErrorStatus

Controls the behavior of the indicators (such as LEDs) showing the status of the Device.

Possible values are:

- **Inactive:** Device's indicators are inactive (Off).
- **Active:** Device's indicators are active showing their respective status.
- **ErrorStatus:** Device's indicators are inactive unless an error occurs.

3.53 DeviceFeaturePersistenceStart

Name	DeviceFeaturePersistenceStart
Level	Optional
Interface	ICommand
Access	(Read)/Write
Unit	-
Visibility	Guru
Values	-

Indicate to the device and GenICam XML to get ready for persisting of all streamable features.

Note that device persistence is done by reading the device features and saving them outside of the device.

3.54 DeviceFeaturePersistenceEnd

Name	DeviceFeaturePersistenceEnd
-------------	-----------------------------

Level	Optional
Interface	ICommand
Access	(Read)/Write
Unit	-
Visibility	Guru
Values	-

Indicate to the device the end of feature persistence.

3.55 DeviceRegistersStreamingStart

Name	DeviceRegistersStreamingStart
Category	DeviceControl
Level	Recommended
Interface	ICommand
Access	(Read)/Write
Unit	-
Visibility	Guru
Values	-

Prepare the device for registers streaming without checking for consistency.

If the camera implements this feature, GenApi guarantees using it to announce register streaming.

If the feature is present, but currently not writable (locked), the application must not start register streaming and must avoid switching the access mode and range verification off until the feature becomes writable again.

3.56 DeviceRegistersStreamingEnd

Name	DeviceRegistersStreamingEnd
Category	DeviceControl
Level	Recommended
Interface	ICommand
Access	(Read)/Write
Unit	-
Visibility	Guru
Values	-

Announce the end of registers streaming. This will do a register set validation for consistency and activate it. This will also update the **DeviceRegistersValid** flag.

3.57 DeviceRegistersCheck

Name	DeviceRegistersCheck
Category	DeviceControl
Level	Recommended
Interface	ICommand
Access	(Read)/Write
Unit	-
Visibility	Expert
Values	-

Perform the validation of the current register set for consistency. This will update the **DeviceRegistersValid** flag.

3.58 DeviceRegistersValid

Name	DeviceRegistersValid
Category	DeviceControl
Level	Recommended
Interface	IBoolean
Access	Read
Unit	-
Visibility	Expert
Values	True False

Returns if the current register set is valid and consistent.

3.59 DeviceRegistersEndianness

Name	DeviceRegistersEndianness
Category	DeviceControl
Level	Optional
Interface	IEnumeration
Access	Read/(Write)
Unit	-
Visibility	Guru

Values	Big Little
---------------	---------------

Endianness of the registers of the device.

Possible values are:

- **Big:** Device's registers are big Endian.
- **Little:** Device's registers are little Endian.

3.60 DeviceTemperatureSelector

Name	DeviceTemperatureSelector
Category	DeviceControl
Level	Optional
Interface	IEnumeration
Access	Read/Write
Unit	-
Visibility	Expert
Values	Sensor Mainboard Device-specific

Selects the location within the device, where the temperature will be measured.

Possible values are:

- **Sensor:** Temperature of the image sensor of the camera.
- **Mainboard:** Temperature of the device's mainboard.

3.61 DeviceTemperature

Name	DeviceTemperature [DeviceTemperatureSelector]
Category	DeviceControl
Level	Optional
Interface	IFloat
Access	Read
Unit	C
Visibility	Expert
Values	Device-specific

Device temperature in degrees Celsius (C). It is measured at the location selected by DeviceTemperatureSelector.

3.62 DeviceClockSelector

Name	DeviceClockSelector
Category	DeviceControl
Level	Optional
Interface	IEnumeration
Access	Read/(Write)
Unit	-
Visibility	Expert
Values	Sensor SensorDigitization CameraLink Device-specific

Selects the clock frequency to access from the device.

Possible values are:

- **Sensor:** Clock frequency of the image sensor of the camera.
- **SensorDigitization:** Clock frequency of the camera A/D conversion stage.
- **CameraLink:** Frequency of the Camera Link clock.

3.63 DeviceClockFrequency

Name	DeviceClockFrequency [DeviceClockSelector]
Category	DeviceControl
Level	Optional
Interface	IFloat
Access	Read/(Write)
Unit	Hz
Visibility	Expert
Values	≥ 0

Returns the frequency of the selected Clock.

3.64 DeviceSerialPortSelector

Name	DeviceSerialPortSelector
-------------	--------------------------

Category	DeviceControl
Level	Recommended
Interface	IEnumeration
Access	Read/(Write)
Unit	-
Visibility	Expert
Values	CameraLink Device-specific

Selects which serial port of the device to control.

Possible values are:

- **CameraLink**: Serial port associated to the Camera link connection.

3.65 DeviceSerialPortBaudRate

Name	DeviceSerialPortBaudRate [DeviceSerialPortSelector]
Category	DeviceControl
Level	Recommended
Interface	IEnumeration
Access	Read/(Write)
Unit	-
Visibility	Expert
Values	Baud9600 Baud19200 Baud38400 Baud57600 Baud115200 Baud230400 Baud460800 Baud921600 ...

This feature controls the baud rate used by the selected serial port.

Typical values listed should be used whenever possible. Arbitrary values can also be used by defining new enumeration entries.

Possible values are:

- **Baud9600**: Serial port speed of 9600 baud.

- **Baud19200**: Serial port speed of 19200 baud.
- **Baud38400**: Serial port speed of 38400 baud.
- **Baud57600**: Serial port speed of 57600 baud.
- **Baud115200**: Serial port speed of 115200 baud.
- **Baud230400**: Serial port speed of 230400 baud.
- **Baud460800**: Serial port speed of 460800 baud.
- **Baud921600**: Serial port speed of 921600 baud.

3.66 Timestamp

Name	Timestamp
Category	DeviceControl
Level	Recommended
Interface	IInteger
Access	Read
Unit	ns
Visibility	Expert
Values	≥ 0

Reports the current value of the device timestamp counter.

The same timestamp counter is used for tagging images, chunk and event data.

Note that the increment of the Timestamp feature must correspond to the resolution of the devices's timestamp in nanoseconds.

3.67 TimestampReset

Name	TimestampReset
Category	DeviceControl
Level	Optional
Interface	ICommand
Access	(Read)/Write
Unit	-
Visibility	Expert
Values	-

Resets the current value of the device timestamp counter.

After executing this command, the timestamp counter restarts automatically.

3.68 TimestampLatch

Name	TimestampLatch
Category	DeviceControl
Level	Optional
Interface	ICommand
Access	(Read)/Write
Unit	-
Visibility	Expert
Values	-

Latches the current timestamp counter into TimestampLatchValue.

3.69 TimestampLatchValue

Name	TimestampLatchValue
Category	DeviceControl
Level	Optional
Interface	IInteger
Access	Read
Unit	ns
Visibility	Expert
Values	≥ 0

Returns the latched value of the timestamp counter.

Note that the increment of the TimestampLatchValue feature must correspond to the resolution of the devices's timestamp in nanoseconds.

4 Image Format Control

This chapter describes how to influence and determine the image size and format. It also provides the necessary information to acquire and to display the image data. It assumes that the device has a Source of data that generates a single rectangular image. This image can be entirely or partially streamed out of the device using one or many Region of interest (ROI).

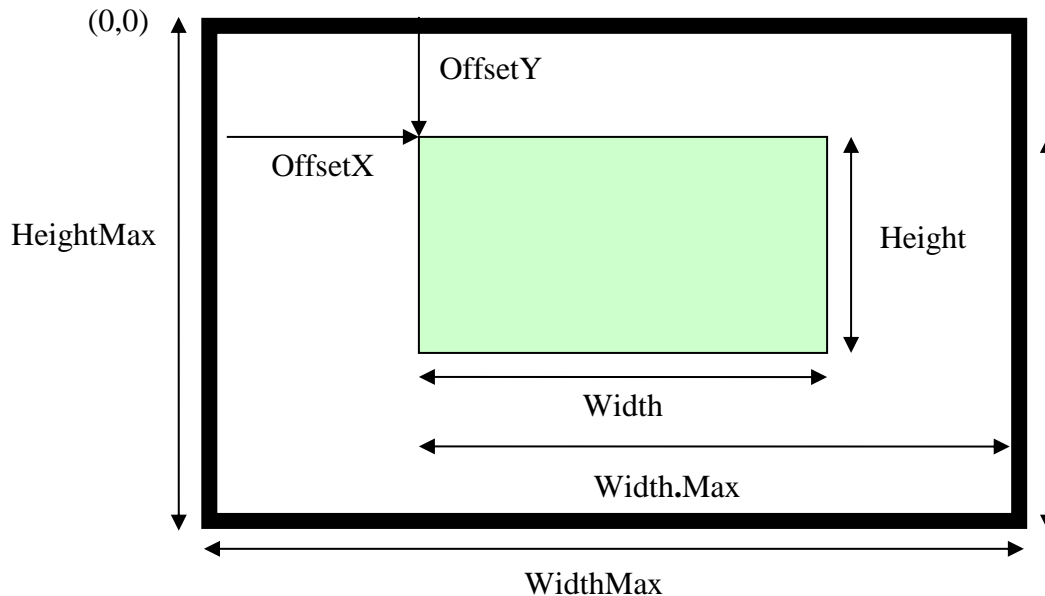

Figure 4-1: Image size and defining a Region of interest

The sensor provides **SensorWidth** times **SensorHeight** pixels.

Using **BinningHorizontal** and/or **BinningVertical** or **DecimationHorizontal** and/or **DecimationVertical** the image is shrunk to **WidthMax** times **HeightMax** pixels.

In addition the features **ReverseX** and **ReverseY** can be used to flip the image respectively along the X-axis or Y-axis. The flipping is done before the Region of interest is applied.

Within the shrunk image the user can set a Region of interest using the features **OffsetX**, **OffsetY**, **Width**, and **Height**. The resulting image generated by the device has **Width** time **Height** pixels. **OffsetX** and **OffsetY** are given with respect to the upper left corner of the image which has the coordinate (0, 0) (see Figure 4-1). If multiple Regions of interest are supported by the device, the **RegionSelector**, **RegionMode** and **RegionDestination** features can be used to select and control each Region individually. All measures are given in pixel. As a result the values should not change if the **PixelFormat** changes. For monochrome cameras each pixel corresponds to one gray value. For color camera in raw mode (Bayer pattern, etc.) each pixel corresponds to one pixel in the color mask. For color cameras in RGB mode each pixel corresponds to one RGB triplet. For color cameras in YUV mode each pixel corresponds to one Y value with the associated color information.

The feature **Height** describes the height of the image in lines. The pixels within a line are contiguous. The lines however may be not contiguous, e.g. in order to yield a DWORD alignment. **LinePitch** gives the number of bytes separating the starting pixels of two consecutive lines.

Each pixel in the image has a format defined by the **PixelFormat** feature. Only a subset of the possible pixel formats is presented in this document. The complete list of possible standard pixel formats and their layout can be found in the separate "GenICam Pixel Format Naming Convention (PFNC)" specification (See the [GenICam download page on the EMVA web site](#)). This web page also gives the list of the currently standardized Pixel Formats and their unique Identifier value (See the "GenICam Pixel Format Values" and "Reference header file for PFNC" documents).

Because the **PixelFormat** feature contains a mix of informations specified by the user and informations provided by the device, it is suitable for describing the whole pixel settings but might be less practical when individual setting must be set or inquired. Therefore a second set of features exists composed of the individual components of **PixelFormat**. Those features are **PixelSize**, **PixelColorFilter**, **PixelDynamicRangeMin** and **PixelDynamicRangeMax**.

Even if the **PixelFormat** might allow for, e.g. 16 bits per pixel, the real image data might provide only a certain range of value (e.g. 12 bits per pixel because the camera is equipped with a 12 bit analog to digital converter only). In that case, **PixelDynamicRangeMin** and **PixelDynamicRangeMax** specify the lower and upper limits of the pixel values in the image. In general, **PixelDynamicRangeMin** should be zero and **PixelDynamicRangeMax** should be a power of two ($[0, 2^{DataDepth} - 1]$). There should be no missing codes in the range.

4.1 ImageFormatControl

Name	ImageFormatControl
Category	Root
Level	Recommended
Interface	ICategory
Access	Read
Unit	-
Visibility	Beginner
Values	-

Category for Image Format Control features.

4.2 SensorWidth

Name	SensorWidth
Category	ImageFormatControl
Level	Recommended
Interface	IInteger
Access	Read
Unit	-
Visibility	Expert

Values	>0
---------------	----

Effective width of the sensor in pixels.

4.3 SensorHeight

Name	SensorHeight
Category	ImageFormatControl
Level	Recommended
Interface	IInteger
Access	Read
Unit	-
Visibility	Expert
Values	>0

Effective height of the sensor in pixels.

For linescan sensor, this value is 1.

4.4 SensorPixelWidth

Name	SensorPixelWidth
Category	ImageFormatControl
Level	Optional
Interface	IFloat
Access	Read
Unit	um
Visibility	Guru
Values	>0

Physical size (pitch) in the x direction of a photo sensitive pixel unit.

4.1 SensorPixelHeight

Name	SensorPixelHeight
Category	ImageFormatControl
Level	Optional
Interface	IFloat
Access	Read

Unit	um
Visibility	Guru
Values	>0

Physical size (pitch) in the y direction of a photo sensitive pixel unit.

4.1 SensorName

Name	SensorName
Category	ImageFormatControl
Level	Optional
Interface	IString
Access	Read
Unit	-
Visibility	Guru
Values	Any NULL-terminated string

Product name of the imaging Sensor.

4.2 SensorShutterMode

Name	SensorShutterMode
Category	ImageFormatControl
Level	Optional
Interface	IEnumeration
Access	Read/(Write)
Unit	-
Visibility	Guru
Values	Global Rolling GlobalReset

Specifies the shutter mode of the device.

Possible values are:

- **Global:** The shutter opens and closes at the same time for all pixels. All the pixels are exposed for the same length of time at the same time.

- **Rolling:** The shutter opens and closes sequentially for groups (typically lines) of pixels. All the pixels are exposed for the same length of time but not at the same time.
- **GlobalReset:** The shutter opens at the same time for all pixels but ends in a sequential manner. The pixels are exposed for different lengths of time.

Shutter modes diagrams:

Global:

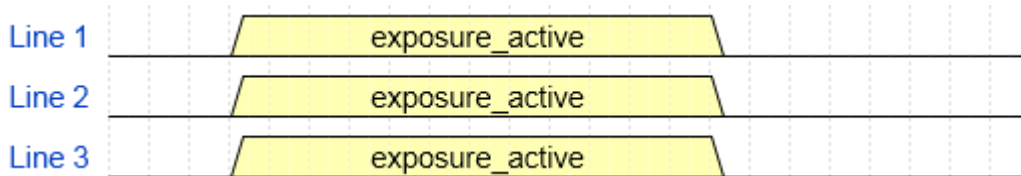

Rolling

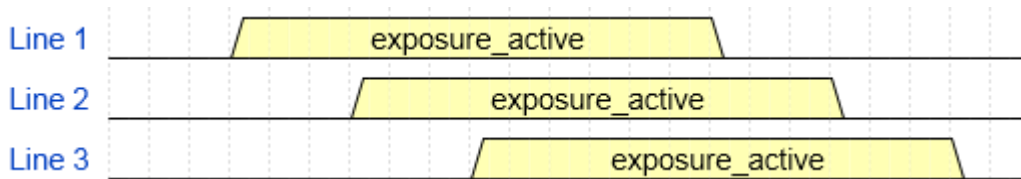

Global Reset:

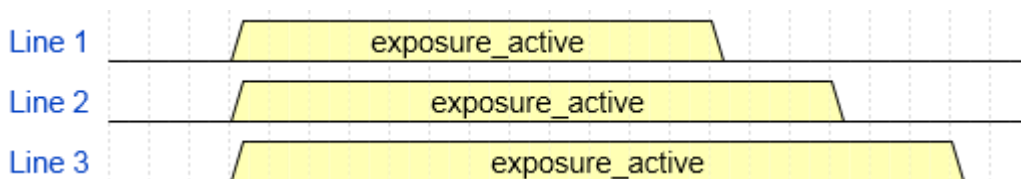

4.3 SensorTaps

Name	SensorTaps
Category	ImageFormatControl
Level	Optional
Interface	IEnumeration
Access	Read/(Write)
Unit	-
Visibility	Expert
Values	One Two Three Four Eight

	Ten ... Device-specific
--	-------------------------------

Number of taps of the camera sensor.

Possible values are:

- **One:** 1 tap.
- **Two:** 2 taps.
- **Three:** 3 taps.
- **Four:** 4 taps.
- **Eight:** 8 taps.
- **Ten:** 10 taps.

4.4 SensorDigitizationTaps

Name	SensorDigitizationTaps
Category	ImageFormatControl
Level	Optional
Interface	IEnumeration
Access	Read/(Write)
Unit	-
Visibility	Expert
Values	One Two Three Four Eight Ten ... Device-specific

Number of digitized samples outputted simultaneously by the camera A/D conversion stage.

Possible values are:

- **One:** 1 tap.
- **Two:** 2 taps.
- **Three:** 3 taps.
- **Four:** 4 taps.

- **Eight:** 8 taps.
- **Ten:** 10 taps.

4.5 WidthMax

Name	WidthMax
Category	ImageFormatControl
Level	Recommended
Interface	IInteger
Access	Read
Unit	-
Visibility	Expert
Values	>0

Maximum width of the image (in pixels). The dimension is calculated after horizontal binning, decimation or any other function changing the horizontal dimension of the image.

WidthMax does not take into account the current Region of interest (Width or OffsetX). Its value must be greater than 0 and less than or equal to SensorWidth (unless an oversampling feature is present).

4.6 HeightMax

Name	HeightMax
Category	ImageFormatControl
Level	Recommended
Interface	IInteger
Access	Read
Unit	-
Visibility	Expert
Values	>0

Maximum height of the image (in pixels). This dimension is calculated after vertical binning, decimation or any other function changing the vertical dimension of the image.

HeightMax does not take into account the current Region of interest (Height or OffsetY). Its value must be greater than 0 and for area scan devices, less than or equal to SensorHeight (unless an oversampling feature is present).

4.7 RegionSelector

Name	RegionSelector
-------------	----------------

Category	ImageFormatControl
Level	Optional
Interface	IEnumeration
Access	Read/(Write)
Unit	-
Visibility	Beginner
Values	Region0 (if 0 based) Region1 Region2 ... Scan3dExtraction0 (if 0 based) Scan3dExtraction1 Scan3dExtraction2 ... All

Selects the Region of interest to control. The RegionSelector feature allows devices that are able to extract multiple regions out of an image, to configure the features of those individual regions independently.

RegionX are generally used to configure Sensor’s regions extraction characteristics. Regions can overlap and can also be used to provide the data of the same region in various PixelFormat or data compression type.

For example to provide the RGB Uncompressed Intensity and the YUV JPEG compressed Intensity of a sensor region:

```

RegionSelector = Region0 // Select Region 0
RegionMode[Region0] = On // Instance 0 (default ON)
ComponentSelector = Intensity // Select Intensity
ComponentEnable[Region0][Intensity] = true // Enable instance 0 streaming (default).
PixelFormat[Region0][Intensity] = RGB8 // RGB 24 bit per pixel.
ImageCompressionMode[Region0][Intensity] = Off // Instance 0 Uncompressed.

RegionSelector = Region1 // Select Region 1
RegionMode[Region1] = On // Instance 1
ComponentSelector = Intensity // Select Intensity
Component[Intensity] = true // Enable instance 1 streaming.
PixelFormat[Region1][Intensity] = YUV422_8 // YUV 16 bit per pixel.
ImageCompressionMode[Region1][Intensity] = JPEG // Instance 1 Compressed
    
```

Other Processing module output Regions can be used to configure the size and characteristics of the processing modules’ output (See for example the "3D Device data output control" chapter). Those Processing Module output regions should take the name of the processing module itself followed by their index (such as Scan3dExtractionX).

Note that if multiple Regions of interest are supported by the device, the **RegionSelector** can be added to various features such as Width, Height,.. to specify the behavior of the selected Region. In order to simplify the standard text and feature descriptions (see above example), the optional **RegionSelector** is not explicitly propagated to all the features of the SFNC that it can potentially select.

Possible values are:

- **Region0**: Selected feature will control the region 0.
- **Region1**: Selected feature will control the region 1.
- **Region2**: Selected feature will control the region 2.
- ...
- **Scan3dExtraction0**: Selected feature will control the Scan3dExtraction0 output Region.
- **Scan3dExtraction1**: Selected feature will control the Scan3dExtraction1 output Region.
- **Scan3dExtraction2**: Selected feature will control the Scan3dExtraction2 output Region.
- ...
- **All**: Selected features will control all the regions at the same time.

4.8 RegionMode

Name	RegionMode[RegionSelector]
Category	ImageFormatControl
Level	Optional
Interface	IEnumeration
Access	Read/Write
sUnit	-
Visibility	Beginner
Values	Off On

Controls if the selected Region of interest is active and streaming.

Possible values are:

- **Off**: Disable the usage of the Region.
- **On**: Enable the usage of the Region.

4.9 RegionDestination

Name	RegionDestination[RegionSelector]
Category	ImageFormatControl
Level	Optional

Interface	IEnumeration
Access	Read/(Write)
Unit	-
Visibility	Expert
Values	Stream0 Stream1 Stream2 ...

Control the destination of the selected region.

Possible values are:

- **Stream0**: The destination of the region is the data stream 0.
- **Stream1**: The destination of the region is the data stream 1.
- **Stream2**: The destination of the region is the data stream 2.
- ...

4.10 RegionIDValue

Name	RegionIDValue[RegionSelector]
Category	ImageFormatControl
Level	Optional
Interface	IInteger
Access	Read
Unit	-
Visibility	Expert
Values	≥0

Returns a unique Identifier value that corresponds to the selected Region.

This value is typically used by the Transport Layer to specify the Region from which the transmitted data come from.

4.11 ComponentSelector

Name	ComponentSelector
Category	ImageFormatControl
Level	Optional
Interface	IEnumeration

Access	Read/Write
Unit	-
Visibility	Beginner
Values	Intensity Infrared Ultraviolet Range Reflectance Confidence Disparity Scatter Device-specific

Selects a component to activate/deactivate its data streaming.

The **ComponentSelector** determines which data acquisition component to control. In a standard (2D) Areascan or Linescan device, Intensity is the typical image component available and it can typically not be turned off. However, for 3D cameras it is often relevant to be able to enable and disable the acquisition of different components.

In a general case, different regions of the sensor can be used to acquire and transmit different content. A typical case is found in many linescan 3D cameras where a region is used to acquire 3D Components while another is used to acquire a different 2D Component. In that case, the ComponentEnable feature will be selected by a RegionSelector in addition to the usual ComponentSelector.

Note that this use case can also be addressed using a SourceSelector and defining multiple (virtual) sensors as described in the Source Control chapter.

Possible values are:

- **Intensity:** The acquisition of intensity (monochrome or color) of the visible reflected light is controlled.
- **Infrared:** The acquisition of non-visible infrared light is controlled.
- **Ultraviolet:** The acquisition of non-visible ultraviolet light is controlled.
- **Range:** The acquisition of range (distance) data is controlled. The data produced may be only range (2.5D) or a point cloud giving the 3D coordinates depending on the Scan3dControl.
- **Reflectance:** The reflected intensity acquired together with Range in a Linescan3D sensor acquiring a single linescan profile for each exposure of the sensor.
- **Confidence:** The acquisition of confidence map of the acquired image is controlled. Confidence data may be binary (0 - invalid) or an integer where 0 is invalid and increasing value is increased confidence in the data in the corresponding pixel. If floating point representation is used the confidence image is normalized to the range [0,1], for integer representation the maximum possible integer represents maximum confidence.

- **Disparity:** The acquisition of stereo camera disparity data is controlled. Disparity is a more specific range format approximately inversely proportional to distance. Disparity is typically given in pixel units.
- **Scatter:** The acquisition of data measuring how much light is scattered around the reflected light. In processing this is used as an additional intensity image, often together with the standard intensity or reflectance.

Multiple components from a region:

The ComponentSelector allows to control the multiple components of a single source region. In this case, all components are defined to be registered (i.e. For each pixel in all components, the data in all images refer to the same source region position. Moreover each component image is of the same size. Note that a single component can be composed of multiple image planes. Apart from the 3D case shown here, this is also true for the planar color components for example.

In the general case, each component can have a different data (pixel) type (e.g. floating point for Range data, unsigned integer for intensity and single bit for confidence).

Note that the transport layer and pixel format definitions in some GenICam-based standards may restrict the usage of multiple components.

Example of multiple components acquisition from a sensor.

```
// Setup for 3D Range+Confidence+Reflectance sent as calibrated Range map.
Scan3dOutputMode           = CalibratedABC_Grid; // XYZ Planar output.
ComponentSelector          = Range;
ComponentEnable[Range]     = True;
ComponentSelector          = Confidence;
ComponentEnable[Confidence] = True;
ComponentSelector          = Reflectance;
ComponentEnable[Reflectance] = True;
```

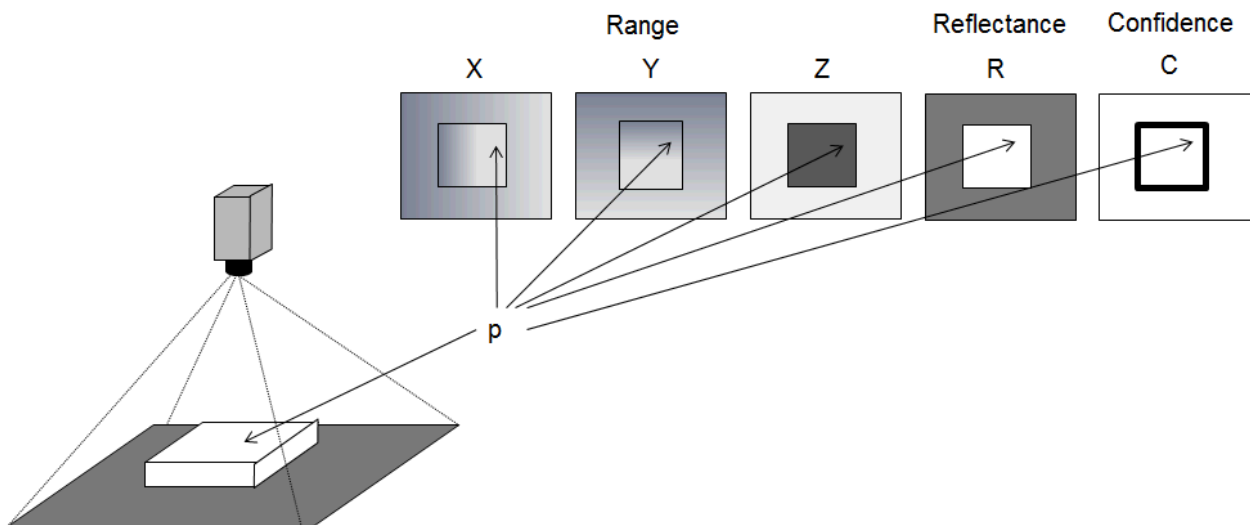

Figure 4-2: Multiple Image components from a full size image

4.12 ComponentEnable

Name	ComponentEnable[RegionSelector][ComponentSelector]
-------------	--

Category	ImageFormatControl
Level	Optional
Interface	IBoolean
Access	Read/(Write)
Unit	-
Visibility	Beginner
Values	True False

Controls if the selected component streaming is active.

Possible values are:

- **True:** Acquisition of component enabled.
- **False:** Acquisition of component disabled.

4.13 ComponentIDValue

Name	ComponentIDValue[ComponentSelector]
Category	ImageFormatControl
Level	Optional
Interface	IInteger
Access	Read
Unit	-
Visibility	Expert
Values	≥ 0

Returns a unique Identifier value that corresponds to the selected Component type.

This value is typically used by the Transport Layer to specify the type of information included in the transmitted Component data.

4.14 ImageComponentSelector (Deprecated)

Name	ImageComponentSelector
Category	ImageFormatControl
Level	Optional
Interface	IEnumeration
Access	Read/Write
Unit	-

Visibility	Invisible
Values	Intensity Color Infrared Ultraviolet Range Confidence Disparity Scatter Device-specific

This feature is deprecated (See **ComponentSelector**). It was used to select a component.

To help backward compatibility, this feature can be included as Invisible in the device's XML.

Possible values are:

- **Intensity:** The acquisition of intensity (monochrome or color) of the visible reflected light is controlled.
- **Color:** The acquisition of color of the reflected light is controlled
- **Infrared:** The acquisition of non-visible infrared light is controlled.
- **Ultraviolet:** The acquisition of non-visible ultraviolet light is controlled.
- **Range:** The acquisition of range (distance) data is controlled. The data produced may be only range (2.5D) or a point cloud 3D coordinates depending on the Scan3dControl.
- **Confidence:** The acquisition of confidence map of the acquired image is controlled. Confidence data may be binary (0 - invalid) or an integer where 0 is invalid and increasing value is increased confidence in the data in the corresponding pixel. If floating point representation is used the confidence image is normalized to the range [0,1], for integer representation the maximum possible integer represents maximum confidence.
- **Disparity:** The acquisition of stereo camera disparity data is controlled. Disparity is a more specific range format approximately inversely proportional to distance. Disparity is typically given in pixel units.
- **Scatter:** The acquisition of data measuring how much light is scattered around the reflected light. In processing this is used as an additional intensity image, often together with the standard intensity.

4.15 ImageComponentEnable (Deprecated)

Name	ImageComponentEnable[RegionSelector][ComponentSelector]
Category	ImageFormatControl
Level	Optional
Interface	IBoolean
Access	Read/(Write)

Unit	-
Visibility	Invisible
Values	True False

This feature is deprecated (See **ComponentEnable**). It was used to control if the selected component streaming is active.

To help backward compatibility, this feature can be included as Invisible in the device's XML.

4.16 Width

Name	Width[RegionSelector]
Category	ImageFormatControl
Level	Recommended
Interface	IInteger
Access	Read/(Write)
Unit	-
Visibility	Beginner
Values	>0

Width of the image provided by the device (in pixels).

This reflects the current Region of interest. The maximum value of this feature takes into account horizontal binning, decimation, or any other function changing the maximum horizontal dimensions of the image and is typically equal to WidthMax - OffsetX.

This feature is generally mandatory for transmitters and transceivers of most Transport Layers.

4.17 Height

Name	Height[RegionSelector]
Category	ImageFormatControl
Level	Recommended
Interface	IInteger
Access	Read/(Write)
Unit	-
Visibility	Beginner
Values	>0

Height of the image provided by the device (in pixels).

This reflects the current Region of interest. The maximum value of this feature takes into account vertical binning, decimation, or any other function changing the maximum vertical dimensions of the image and is typically equal to HeightMax - OffsetY.

This feature is generally mandatory for transmitters and transceivers of most Transport Layers.

4.18OffsetX

Name	OffsetX[RegionSelector]
Category	ImageFormatControl
Level	Recommended
Interface	IInteger
Access	Read/Write
Unit	-
Visibility	Beginner
Values	≥ 0

Horizontal offset from the origin to the region of interest (in pixels).

4.19OffsetY

Name	OffsetY[RegionSelector]
Category	ImageFormatControl
Level	Recommended
Interface	IInteger
Access	Read/Write
Unit	-
Visibility	Beginner
Values	≥ 0

Vertical offset from the origin to the region of interest (in pixels).

4.20LinePitchEnable

Name	LinePitchEnable[RegionSelector]
Category	ImageFormatControl
Level	Recommended
Interface	IBoolean
Access	Read/Write
Unit	-

Visibility	Expert
Values	True False

This feature controls whether the LinePitch feature is writable. Otherwise LinePitch is implicitly controlled by the combination of features like Width, PixelFormat, etc...

4.21 LinePitch

Name	LinePitch[RegionSelector]
Category	ImageFormatControl
Level	Recommended
Interface	IInteger
Access	Read/Write
Unit	B
Visibility	Expert
Values	≥ 0

Total number of bytes between the starts of 2 consecutive lines. This feature is used to facilitate alignment of image data.

This might be useful if the system has specific limitations, such as having the lines aligned on 32-bit boundaries.

4.22 BinningSelector

Name	BinningSelector
Category	ImageFormatControl
Level	Optional
Interface	IEnumeration
Access	Read/(Write)
Unit	-
Visibility	Expert
Values	Sensor Region0 (if 0 based) Region1 Region2 ...

Selects which binning engine is controlled by the BinningHorizontal and BinningVertical features.

Possible values are:

- **Sensor:** Selected features will control the sensor binning.
- **Region0:** Selected feature will control the region 0 binning.
- **Region1:** Selected feature will control the region 1 binning.
- **Region2:** Selected feature will control the region 2 binning.

4.23 BinningHorizontalMode

Name	BinningHorizontalMode[BinningSelector]
Level	Optional
Interface	IEnumeration
Access	Read/(Write)
Unit	-
Visibility	Expert
Values	Sum Average

Sets the mode to use to combine horizontal photo-sensitive cells together when **BinningHorizontal** is used.

Possible values are:

- **Sum:** The response from the combined cells will be added, resulting in increased sensitivity.
- **Average:** The response from the combined cells will be averaged, resulting in increased signal/noise ratio.

4.24 BinningHorizontal

Name	BinningHorizontal[BinningSelector]
Category	ImageFormatControl
Level	Optional
Interface	IInteger
Access	Read/Write
Unit	-
Visibility	Expert
Values	>0

Number of horizontal photo-sensitive cells to combine together. This reduces the horizontal resolution (width) of the image.

A value of 1 indicates that no horizontal binning is performed by the camera.

4.25 BinningVerticalMode

Name	BinningVerticalMode[BinningSelector]
Level	Optional
Interface	IEnumeration
Access	Read/(Write)
Unit	-
Visibility	Expert
Values	Sum Average

Sets the mode to use to combine vertical photo-sensitive cells together when **BinningVertical** is used.

Possible values are:

- **Sum:** The response from the combined cells will be added, resulting in increased sensitivity.
- **Average:** The response from the combined cells will be averaged, resulting in increased signal/noise ratio.

4.26 BinningVertical

Name	BinningVertical[BinningSelector]
Category	ImageFormatControl
Level	Optional
Interface	IInteger
Access	Read/Write
Unit	-
Visibility	Expert
Values	>0

Number of vertical photo-sensitive cells to combine together. This reduces the vertical resolution (height) of the image.

A value of 1 indicates that no vertical binning is performed by the camera.

4.27 DecimationHorizontalMode

Name	DecimationHorizontalMode
Level	Optional
Interface	IEnumeration
Access	Read/(Write)

Unit	-
Visibility	Expert
Values	Discard Average

Sets the mode used to reduce the horizontal resolution when **DecimationHorizontal** is used.

Possible values are:

- **Discard:** The value of every Nth pixel is kept, others are discarded.
- **Average:** The value of a group of N adjacent pixels are averaged.

4.28 DecimationHorizontal

Name	DecimationHorizontal
Category	ImageFormatControl
Level	Optional
Interface	IInteger
Access	Read/Write
Unit	-
Visibility	Expert
Values	>0

Horizontal sub-sampling of the image. This reduces the horizontal resolution (width) of the image by the specified horizontal decimation factor.

A value of 1 indicates that the camera performs no horizontal decimation.

4.29 DecimationVerticalMode

Name	DecimationVerticalMode
Level	Optional
Interface	IEnumeration
Access	Read/(Write)
Unit	-
Visibility	Expert
Values	Discard Average

Sets the mode used to reduce the Vertical resolution when **DecimationVertical** is used.

Possible values are:

- **Discard:** The value of every Nth pixel is kept, others are discarded.
- **Average:** The value of a group of N adjacents pixels are averaged.

4.30 DecimationVertical

Name	DecimationVertical
Category	ImageFormatControl
Level	Optional
Interface	IInteger
Access	Read/Write
Unit	-
Visibility	Expert
Values	>0

Vertical sub-sampling of the image. This reduces the vertical resolution (height) of the image by the specified vertical decimation factor.

A value of 1 indicates that the camera performs no vertical decimation.

4.31 ReverseX

Name	ReverseX
Category	ImageFormatControl
Level	Recommended
Interface	IBoolean
Access	Read/Write
Unit	-
Visibility	Expert
Values	True False

Flip horizontally the image sent by the device. The Region of interest is applied after the flipping.

4.32 ReverseY

Name	ReverseY
Category	ImageFormatControl
Level	Recommended
Interface	IBoolean
Access	Read/Write
Unit	-

Visibility	Expert
Values	True False

Flip vertically the image sent by the device. The Region of interest is applied after the flipping.

4.33 PixelFormat

Name	PixelFormat[ComponentSelector]
Category	ImageFormatControl
Level	Recommended
Interface	IEnumeration
Access	Read/(Write)
Unit	-
Visibility	Beginner
Values	Mono1p Mono2p Mono4p Mono8 Mono8s Mono10 Mono10p Mono12 Mono12p Mono14 Mono16 R8 G8 B8 RGB8 RGB8_Planar RGBa8 RGB10 RGB10_Planar RGB10p32 RGB12 RGB12_Planar RGB16 RGB16_Planar RGB565p BGR10 BGR12

BGR16
 BGR565p
 BGR8
 BGRa8

 YUV422_8

 YCbCr411_8
 YCbCr422_8
 YCbCr601_422_8
 YCbCr709_422_8
 YCbCr8

 BayerBG8
 BayerGB8
 BayerGR8
 BayerRG8
 BayerBG10
 BayerGB10
 BayerGR10
 BayerRG10
 BayerBG12
 BayerGB12
 BayerGR12
 BayerRG12
 BayerBG16
 BayerGB16
 BayerGR16
 BayerRG16

 Coord3D_A8
 Coord3D_B8
 Coord3D_C8
 Coord3D_ABC8
 Coord3D_ABC8_Planar
 Coord3D_A16
 Coord3D_B16
 Coord3D_C16
 Coord3D_ABC16
 Coord3D_ABC16_Planar
 Coord3D_A32f
 Coord3D_B32f
 Coord3D_C32f
 Coord3D_ABC32f
 Coord3D_ABC32f_Planar
 Confidence1
 Confidence1p
 Confidence8

Confidence16
Confidence32f

Raw8
Raw16

Device-specific

- GigE Vision Specific:

Mono12Packed
BayerGR10Packed
BayerRG10Packed
BayerGB10Packed
BayerBG10Packed
BayerGR12Packed
BayerRG12Packed
BayerGB12Packed
BayerBG12Packed
RGB10V1Packed
RGB12V1Packed

- Deprecated:

Mono8Signed (Deprecated, use Mono8s)
RGB8Packed (Deprecated, use RGB8)
BGR8Packed (Deprecated, use BGR8)
RGBA8Packed (Deprecated, use RGBa8)
BGRA8Packed (Deprecated, use BGRa8)
RGB10Packed (Deprecated, use RGB10)
BGR10Packed (Deprecated, use BGR10)
RGB12Packed (Deprecated, use RGB12)
BGR12Packed (Deprecated, use BGR12)
RGB16Packed (Deprecated, use RGB16)
BGR16Packed (Deprecated, use BGR16)
RGB10V2Packed (Deprecated, use RGB10p32)
BGR10V2Packed (Deprecated, use BGR10p32)
RGB565Packed (Deprecated, use RGB565p)
BGR565Packed (Deprecated, use BGR565p)
YUV411Packed (Deprecated, use YUV411_8_UYYVYY)
YUV422Packed (Deprecated, use YUV422_8_UYVY)
YUV444Packed (Deprecated, use YUV8_UYV)
YUYVPacked (Deprecated, use YUV422_8)
RGB8Planar (Deprecated, use RGB8_Planar)
RGB10Planar (Deprecated, use RGB10_Planar)
RGB12Planar (Deprecated, use RGB12_Planar)
RGB16Planar (Deprecated, use RGB16_Planar)

Format of the pixels provided by the device. It represents all the information provided by **PixelSize**, **PixelColorFilter** combined in a single feature.

Note that only a subset of the possible pixel formats is listed in this document. The complete list of currently standardized pixel formats and their assigned identifier value can be found in the "GenICam Pixel Format values" document or in the "Reference Header file for PFNC" on the [GenICam download page on the EMVA web site](#). See also the "GenICam Pixel Format Naming Convention" document for information on the detailed layout of those standard formats.

This feature is generally mandatory for transmitters and transceivers of most Transport Layers. You can refer to the appropriate transport layer specification for additional information.

Note: Transport Layer standards using frame grabbers on the receiver side may code the pixels differently than the PFNC on the link (to save bandwidth for example). In that case, the standard will define how the data is coded for each supported pixel format, and will define the requirements for the frame grabber to convert the data into a PFNC compliant pixel format.

Possible values are:

- **Mono1p**: Mono 1 bit packed.
- **Mono2p**: Mono 2 bit packed.
- **Mono4p**: Mono 4 bit packed.
- **Mono8**: Mono 8 bit packed.
- **Mono8s**: Mono 1 bit signed.
- **Mono10**: Mono 10 bit.
- **Mono10p**: Mono 10 bit packed.
- **Mono12**: Mono 12 bit.
- **Mono12p**: Mono 12 bit packed.
- **Mono14**: Mono 14 bit.
- **Mono16**: Mono 16 bit.
- **R8**: Red 8 bit.
- **G8**: Green 8 bit.
- **B8**: Blue 8 bit.
- **RGB8**: Red, Green, Blue 8 bit
- **RGB8_Planar**: Red, Green, Blue 8 bit planar.
- **RGBa8**: Red, Green, Blue 8 bit aligned on 8 bit
- **RGB10**: Red, Green, Blue 10 bit.
- **RGB10_Planar**: Red, Green, Blue 10 bit planar.
- **RGB10p32**: Red, Green, Blue 10 bit packed in 32 bit pixel.
- **RGB12**: Red, Green, Blue 12 bit.
- **RGB12_Planar**: Red, Green, Blue 12 bit planar.

- **RGB16:** Red, Green, Blue 16 bit.
- **RGB16_Planar:** Red, Green, Blue 16 bit planar.
- **RGB565p:** Red, Green, Blue 16 bit packet in 5, 6, 5 bits.
- **BGR10:** Blue, Green, Red, 10 bit.
- **BGR12:** Blue, Green, Red, 12 bit.
- **BGR16:** Blue, Green, Red, 16 bit.
- **BGR565p:** Blue, Green, Red, 16 bit packet in 5, 6, 5 bits.
- **BGR8:** Blue, Green, Red, 8 bit.
- **BGRa8:** Blue, Green, Red, Alpha 8 bit.
- **YUV422_8:** YUV 422 8 bit.
- **YCbCr411_8:** YCrCb 411 8 bit.
- **YCbCr422_8:** YCrCb 422 8 bit.
- **YCbCr601_422_8:** YCrCb 601 422 8 bit.
- **YCbCr709_422_8:** YCrCb 709 422 8 bit.
- **YCbCr8:** YCbCr 8 bit.
- **BayerBG8:** Bayer Blue Green 8 bit.
- **BayerGB8:** Bayer Green Blue 8 bit.
- **BayerGR8:** Bayer Green Red 8 bit.
- **BayerRG8:** Bayer Red Green 8 bit.
- **BayerBG10:** Bayer Blue Green 10 bit.
- **BayerGB10:** Bayer Green Blue 10 bit.
- **BayerGR10:** Bayer Green Red 10 bit.
- **BayerRG10:** Bayer Red Green 10 bit.
- **BayerBG12:** Bayer Blue Green 12 bit
- **BayerGB12:** Bayer Green Blue 12 bit
- **BayerGR12:** Bayer Green Red 12 bit.
- **BayerRG12:** Bayer Red Green 12 bit.
- **BayerBG16:** Bayer Blue Green 16 bit.
- **BayerGB16:** Bayer Green Blue 16 bit.
- **BayerGR16:** Bayer Green Red 16 bit.
- **BayerRG16:** Bayer Red Green 16 bit.
- **Coord3D_A8:** 3D coordinate, first component 8 bit.
- **Coord3D_B8:** 3D coordinate, second component 8 bit.

- **Coord3D_C8:** 3D coordinate, third component 8 bit.
- **Coord3D_ABC8:** 3D coordinates, 3 components 8 bit.
- **Coord3D_ABC8_Planar:** 3D coordinates, 3 components 8 bit planar.
- **Coord3D_A16:** 3D coordinate, first component 16 bit.
- **Coord3D_B16:** 3D coordinate, second component 16 bit.
- **Coord3D_C16:** 3D coordinate, third component 16 bit.
- **Coord3D_ABC16:** 3D coordinates, 3 components 16 bit.
- **Coord3D_ABC16_Planar:** 3D coordinates, 3 components 16 bit planar.
- **Coord3D_A32f:** 3D coordinate, first component 32 bit float.
- **Coord3D_B32f:** 3D coordinate, second component 32 bit float.
- **Coord3D_C32f:** 3D coordinate, third component 32 bit float.
- **Coord3D_ABC32f:** 3D coordinates, 3 components 32 bit float.
- **Coord3D_ABC32f_Planar:** 3D coordinates, 3 components 32 bit float planar.
- **Confidence1:** Confidence data 1 bit.
- **Confidence1p:** Confidence data 1 bit packed.
- **Confidence8:** Confidence data 8 bit.
- **Confidence16:** Confidence data 16 bit.
- **Confidence32f:** Confidence data 32 bit float.
- **Raw8:** Raw 8 bit.
- **Raw16:** Raw 16 bit.
- **Mono12Packed:** Mono 12 bit packed (GigE Vision Specific).
- **BayerGR10Packed:** Bayer GR 10 bit packed (GigE Vision Specific).
- **BayerRG10Packed:** Bayer RG 10 bit packed (GigE Vision Specific).
- **BayerGB10Packed:** Bayer GB 10 bit packed (GigE Vision Specific).
- **BayerBG10Packed:** Bayer BG 10 bit packed (GigE Vision Specific).
- **BayerGR12Packed:** Bayer GR 12 bit packed (GigE Vision Specific).
- **BayerRG12Packed:** Bayer RG 12 bit packed (GigE Vision Specific).
- **BayerGB12Packed:** Bayer GB 12 bit packed (GigE Vision Specific).
- **BayerBG12Packed:** Bayer BG 12 bit packed (GigE Vision Specific).
- **RGB10V1Packed:** RGB 10 bit packed (GigE Vision Specific).
- **RGB12V1Packed:** RGB 12 bit packed (GigE Vision Specific).
- ...

4.34 PixelFormatInfoSelector

Name	PixelFormatInfoSelector
Category	ImageFormatControl
Level	Recommended
Interface	IEnumeration
Access	Read/Write
Unit	-
Visibility	Guru
Values	Mono1p Mono2p Mono4p Mono8 Mono10 Mono10p ...

Select the pixel format for which the information will be returned.

The pixel format selected must be one of the values present in the **PixelFormat** feature.

Possible values are:

- **Mono1p**: Mono 1 bit packed.
- **Mono2p**: Mono 2 bit packed.
- **Mono4p**: Mono 4 bit packed.
- **Mono8**: Mono 8 bit packed.
- **Mono10**: Mono 10 bit.
- **Mono10p**: Mono 10 bit packed.
- ...

Note: This feature must be a floating node and should always be available.

4.35 PixelFormatInfoID

Name	PixelFormatInfoID[PixelFormatInfoSelector]
Category	ImageFormatControl
Level	Recommended
Interface	IInteger
Access	Read
Unit	-
Visibility	Guru

Values	-
---------------	---

Returns the value used by the streaming channels to identify the selected pixel format.

This value is generally equal to the standardized GenICam PFNC value for the selected **PixelFormat**.

To change the Pixel format of the data that will be sent by the device, the **PixelFormat** feature should be used.

Note: This feature must be a floating node and should always be available.

4.36 PixelCoding (Deprecated)

Name	PixelCoding
Category	ImageFormatControl
Level	Recommended
Interface	IEnumeration
Access	Read/(Write)
Unit	-
Visibility	Invisible
Values	Mono MonoSigned MonoPacked RGBPacked BGRPacked RGBAPacked BGRAPacked RGBPlanar YUV411Packed YUV422Packed YUV444Packed YUYVPacked Raw RawPacked

This feature is deprecated. It represents the coding of the pixels in the image. Raw gives the data in the native format of the sensor.

Possible values are:

- **Mono:** Mono.
- **MonoSigned:** Mono signed.
- **MonoPacked:** Mono packed.
- **RGBPacked:** RGB packed.
- **BGRPacked:** BGR packed.

- **RGBAPacked**: RGBA packed.
- **BGRAPacked**: BGRA packed.
- **RGBPlanar**: RGB planar.
- **YUV411Packed**: YUV 411 packed.
- **YUV422Packed**: YUV 422 packed.
- **YUV444Packed**: YUV 444 packed.
- **YUYVPacked**: YUYV packed.
- **Raw**: Raw.
- **RawPacked**: Raw packed.

Raw is mainly used for Bayer sensor. This value must always be coherent with the **PixelFormat** feature.

4.37 PixelSize

Name	PixelSize[ComponentSelector]
Category	ImageFormatControl
Level	Recommended
Interface	IEnumeration
Access	Read/(Write)
Unit	-
Visibility	Expert
Values	Bpp1 Bpp2 Bpp4 Bpp8 Bpp10 Bpp12 Bpp14 Bpp16 Bpp20 Bpp24 Bpp30 Bpp32 Bpp36 Bpp48 Bpp64 Bpp96

Total size in bits of a pixel of the image.

This value must always be coherent with the **PixelFormat** feature.

Possible values are:

- **Bpp1**: 1 bit per pixel.
- **Bpp2**: 2 bits per pixel.
- **Bpp4**: 4 bits per pixel.
- **Bpp8**: 8 bits per pixel.
- **Bpp10**: 10 bits per pixel.
- **Bpp12**: 12 bits per pixel.
- **Bpp14**: 14 bits per pixel.
- **Bpp16**: 16 bits per pixel.
- **Bpp20**: 20 bits per pixel.
- **Bpp24**: 24 bits per pixel.
- **Bpp30**: 30 bits per pixel.
- **Bpp32**: 32 bits per pixel.
- **Bpp36**: 36 bits per pixel.
- **Bpp48**: 48 bits per pixel.
- **Bpp64**: 64 bits per pixel.
- **Bpp96**: 96 bits per pixel.

4.38 PixelColorFilter

Name	PixelColorFilter[ComponentSelector]
Category	ImageFormatControl
Level	Recommended
Interface	IEnumeration
Access	Read/(Write)
Unit	-
Visibility	Expert
Values	None BayerRG BayerGB BayerGR BayerBG

Type of color filter that is applied to the image.

This value must always be coherent with the **PixelFormat** feature.

Possible values are:

- **None**: No color filter.
- **BayerRG**: Bayer Red Green filter.
- **BayerGB**: Bayer Green Blue filter.
- **BayerGR**: Bayer Green Red filter.
- **BayerBG**: Bayer Blue Green filter.

4.39 PixelDynamicRangeMin

Name	PixelDynamicRangeMin[ComponentSelector]
Category	ImageFormatControl
Level	Optional
Interface	IInteger
Access	Read/Write
Unit	-
Visibility	Expert
Values	Device-specific

Minimum value that can be returned during the digitization process. This corresponds to the darkest value of the camera. For color camera, this returns the smallest value that each color component can take.

4.40 PixelDynamicRangeMax

Name	PixelDynamicRangeMax[ComponentSelector]
Category	ImageFormatControl
Level	Optional
Interface	IInteger
Access	Read/Write
Unit	-
Visibility	Expert
Values	Device-specific

Maximum value that will be returned during the digitization process. This corresponds to the brightest value of the camera. For color camera, this returns the biggest value that each color component can take.

4.41 TestPatternGeneratorSelector

Name	TestPatternGeneratorSelector
Category	ImageFormatControl

Level	Optional
Interface	IEnumeration
Access	Read/(Write)
Unit	-
Visibility	Beginner
Values	Sensor Region0 (if 0 based) Region1 Region2 ...

Selects which test pattern generator is controlled by the TestPattern feature.

Possible values are:

- **Sensor:** TestPattern feature will control the sensor's test pattern generator.
- **Region0:** TestPattern feature will control the region 0 test pattern generator.
- **Region1:** TestPattern feature will control the region 1 test pattern generator.
- **Region2:** TestPattern feature will control the region 2 test pattern generator.
- ...

4.42 TestPattern

Name	TestPattern[TestPatternGeneratorSelector]
Category	ImageFormatControl
Level	Optional
Interface	IEnumeration
Access	Read/Write
Unit	-
Visibility	Beginner
Values	Off Black White GreyHorizontalRamp GreyVerticalRamp GreyHorizontalRampMoving GreyVerticalRampMoving HorizontalLineMoving VerticalLineMoving ColorBar FrameCounter

Device-specific

Selects the type of test pattern that is generated by the device as image source.

Possible values are:

- **Off:** Image is coming from the sensor.
- **Black:** Image is filled with the darkest possible image.
- **White:** Image is filled with the brightest possible image.
- **GreyHorizontalRamp:** Image is filled horizontally with an image that goes from the darkest possible value to the brightest.
- **GreyVerticalRamp:** Image is filled vertically with an image that goes from the darkest possible value to the brightest.
- **GreyHorizontalRampMoving:** Image is filled horizontally with an image that goes from the darkest possible value to the brightest and that moves horizontally from left to right at each frame.
- **GreyVerticalRampMoving:** Image is filled vertically with an image that goes from the darkest possible value to the brightest and that moves vertically from top to bottom at each frame.
- **HorizontalLineMoving:** A moving horizontal line is superimposed on the live image.
- **VerticalLineMoving:** A moving vertical line is superimposed on the live image.
- **ColorBar:** Image is filled with stripes of color including White, Black, Red, Green, Blue, Cyan, Magenta and Yellow.
- **FrameCounter:** A frame counter is superimposed on the live image.

Other values are device-specific and represent particular test images digitally generated by the camera.

4.43 TestImageSelector (Deprecated)

Name	TestImageSelector
Category	ImageFormatControl
Level	Optional
Interface	IEnumeration
Access	Read/Write
Unit	-
Visibility	Invisible
Values	Off Black White GreyHorizontalRamp

	<p>GreyVerticalRamp GreyHorizontalRampMoving GreyVerticalRampMoving HorizontalLineMoving VerticalLineMoving ColorBar FrameCounter Device-specific</p>
--	--

This feature is deprecated (See **TestPattern**). Selects the type of test image that is sent by the device.

To help backward compatibility, this feature can be included as Invisible in the device's XML.

Possible values are:

- **Off**: Image is coming from the sensor.
- **Black**: Image is filled with the darkest possible image.
- **White**: Image is filled with the brightest possible image.
- **GreyHorizontalRamp**: Image is filled horizontally with an image that goes from the darkest possible value to the brightest.
- **GreyVerticalRamp**: Image is filled vertically with an image that goes from the darkest possible value to the brightest.
- **GreyHorizontalRampMoving**: Image is filled horizontally with an image that goes from the darkest possible value to the brightest and that moves horizontally from left to right at each frame.
- **GreyVerticalRampMoving**: Image is filled vertically with an image that goes from the darkest possible value to the brightest and that moves vertically from top to bottom at each frame.
- **HorizontalLineMoving**: A moving horizontal line is superimposed on the live image.
- **VerticalLineMoving**: A moving vertical line is superimposed on the live image.
- **ColorBar**: Image is filled with stripes of color including White, Black, Red, Green, Blue, Cyan, Magenta and Yellow.
- **FrameCounter**: A frame counter is superimposed on the live image.

Other values are device-specific and represent particular test images digitally generated by the camera.

4.44 Deinterlacing

Name	Deinterlacing
Category	ImageFormatControl
Level	Optional
Interface	IEnumeration

Access	Read/Write
Unit	-
Visibility	Beginner
Values	Off LineDuplication Weave ... Device-specific

Controls how the device performs de-interlacing.

Possible values are:

- **Off:** The device doesn't perform de-interlacing.
- **LineDuplication:** The device performs de-interlacing by outputting each line of each field twice.
- **Weave:** The device performs de-interlacing by interleaving the lines of all fields.

4.45 Image Compression

This section describes the feature related to image compression.

4.45.1 ImageCompressionMode

Name	ImageCompressionMode
Category	ImageFormatControl
Level	Optional
Interface	IEnumeration
Access	Read/Write
Visibility	Beginner
Unit	-
Values	Off JPEG JPEG2000 H264 ... Device-specific

Enable a specific image compression mode as the base mode for image transfer. Optionally, chunk data can be appended to the compressed image (See the Chunk Data Control chapter).

Possible values are:

- **Off:** Default value. Image compression is disabled. Images are transmitted uncompressed.
- **JPEG:** JPEG compression is selected.
- **JPEG2000:** JPEG 2000 compression is selected.
- **H264:** H.264 compression is selected.

4.45.2 ImageCompressionRateOption

Name	ImageCompressionRateOption
Category	ImageFormatControl
Level	Optional
Interface	IEnumeration
Access	Read/Write
Unit	-
Visibility	Expert
Values	FixBitrate FixQuality ... Device-specific

Two rate controlling options are offered: fixed bit rate or fixed quality. The exact implementation to achieve one or the other is vendor-specific.

Note that not all compression techniques or implementations may support this feature.

Possible values are:

- **FixBitrate:** Output stream follows a constant bit rate. Allows easy bandwidth management on the link.
- **FixQuality:** Output stream has a constant image quality. Can be used when image processing algorithms are sensitive to image degradation caused by excessive data compression.

4.45.3 ImageCompressionQuality

Name	ImageCompressionQuality
Category	ImageFormatControl
Level	Optional
Interface	IInteger
Access	Read/(Write)
Unit	-
Visibility	Expert
Values	Device-specific

Control the quality of the produced compressed stream.
2018-6-26

This feature is available when ImageCompressionRateOption is equal to FixQuality or if the device only supports the FixQuality mode.

The list of valid values is device-specific. A higher value means a better quality for the produced compressed stream.

4.45.4 ImageCompressionBitrate

Name	ImageCompressionBitrate
Category	ImageFormatControl
Level	Optional
Interface	IFloat
Access	Read/(Write)
Unit	Mbps
Visibility	Expert
Values	Device-specific

Control the rate of the produced compressed stream.

This feature is available when ImageCompressionRateOption is equals to FixBitrate or if the device only supports the FixBitrate mode.

The list of valid values is device specific.

4.45.5 ImageCompressionJPEGFormatOption

Name	ImageCompressionJPEGFormatOption
Category	ImageFormatControl
Level	Optional
Interface	IEnumeration
Access	Read/Write
Unit	-
Visibility	Expert
Values	Lossless BaselineStandard BaselineOptimized Progressive ... Device-specific

When JPEG is selected as the compression format, a device might optionally offer better control over JPEG-specific options through this feature.

Possible values are:

- **Lossless:** Selects lossless JPEG compression based on a predictive coding model.
- **BaselineStandard:** Indicates this is a baseline sequential (single-scan) DCT-based JPEG.
- **BaselineOptimized:** Provides optimized color and slightly better compression than baseline standard by using custom Huffman tables optimized after statistical analysis of the image content.
- **Progressive:** Indicates this is a progressive (multi-scan) DCT-based JPEG.

5 Acquisition Control

The Acquisition Control chapter describes all features related to image acquisition, including the trigger and exposure control. It describes the basic model for acquisition and the typical behavior of the device.

5.1 Acquisition related vocabulary and signals

This section describes the vocabulary and terms used to describe and name the acquisition related features. It also defines the acquisition related signals and their position in time during the acquisition of images by a device.

An **Acquisition** is composed of one or many **Frames** made of **Line(s)**. The **Frames** of an **Acquisition** can optionally be grouped in smaller **Bursts** that are triggered individually. An **Acquisition** is defined as the capture of a sequence of one or many **Frame(s)** (See Figure 5-1).

The transfer of the frame(s) of an **Acquisition** starts with the beginning of the transfer of the first frame and ends with the completion of the transfer of the last one.

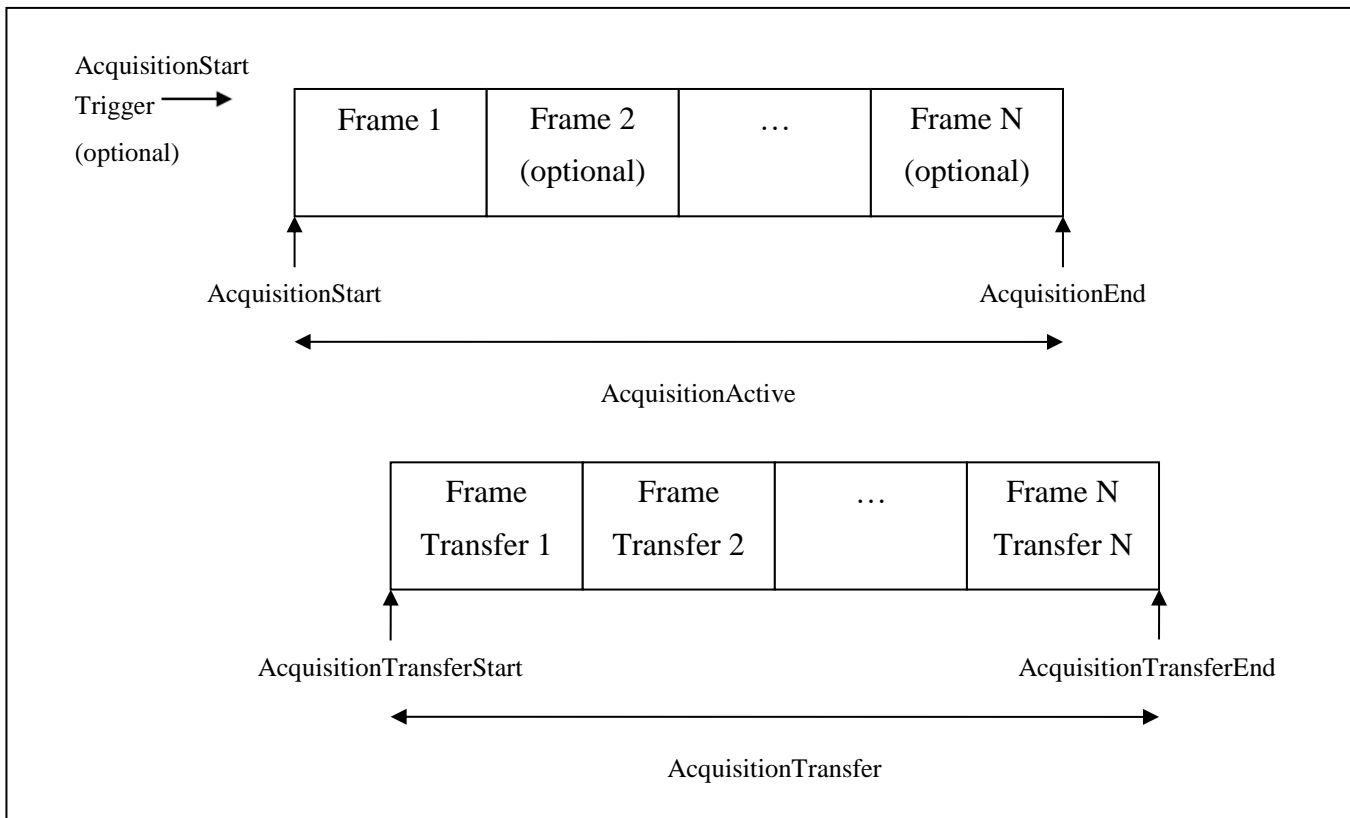

Figure 5-1: Acquisition signals definition

A **Burst** of **Frame(s)** is defined as the capture of a group of one or many **Frame(s)** within an **Acquisition** (See Figure 5-1). If a **FrameBurstStart** or **FrameBurstActive** trigger is enabled (its **TriggerMode=On**), an acquisition can be broken in many smaller **Bursts**. In this case, each **Burst** has its own trigger. If only the **FrameBurstStart** trigger is enabled, **AcquisitionBurstFrameCount** determines the length of each burst. If the **FrameBurstStart** and **FrameBurstEnd** triggers are enabled, they are used to delimit the length of every single burst. If the **FrameBurstActive** trigger is enabled, it determines the length of each individual burst (the burst lasts as long as the trigger is asserted).

The transfer of the frame(s) of a burst starts with the beginning of the transfer of the first frame of the burst and end with the completion of the transfer of the last one.

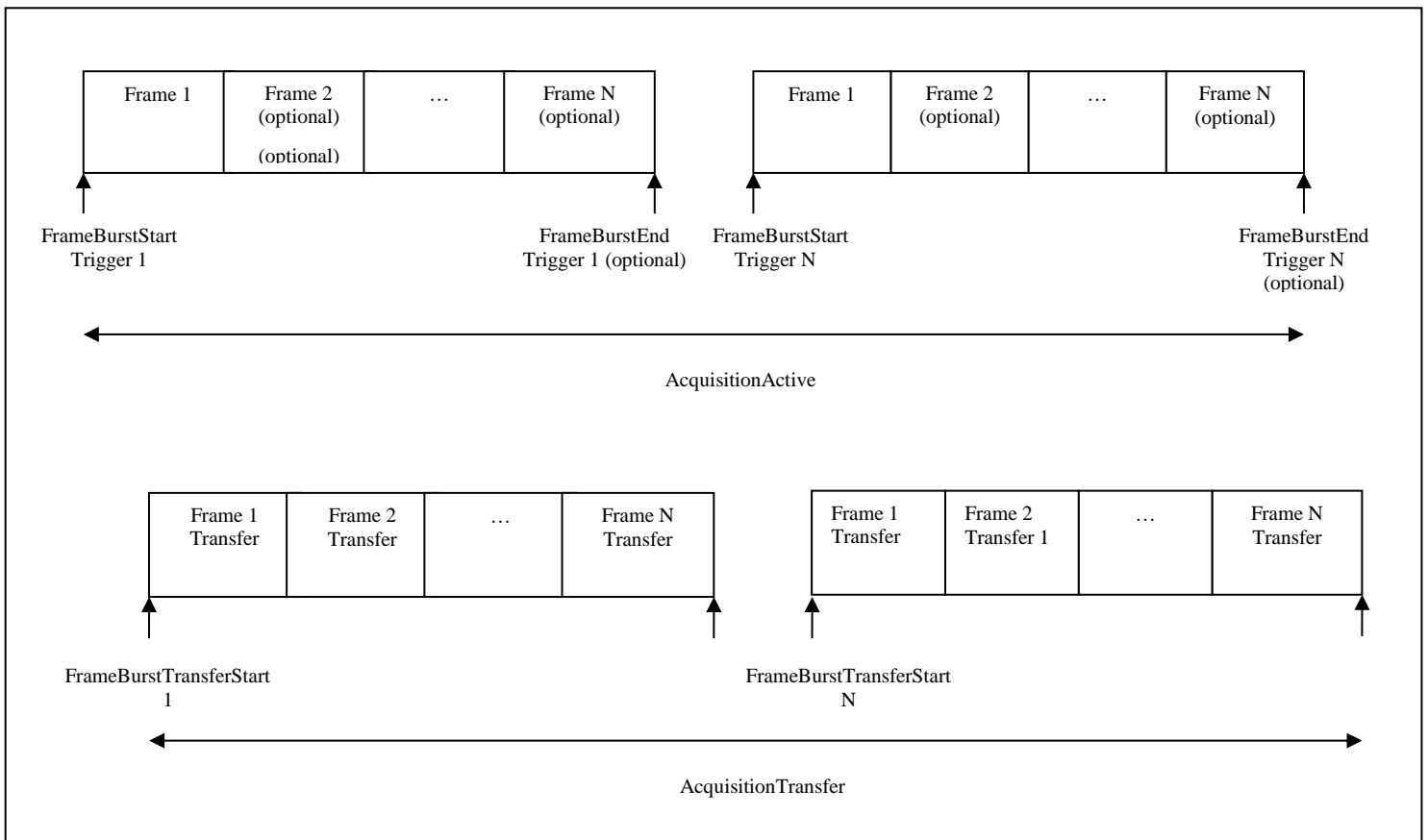

Figure 5-2: Burst signals definition

A **Frame** is defined as the capture of **Width** pixels x **Height** lines. A **Frame** starts with an optional **Exposure** period and ends with the completion of the sensor read out. Generally, a transfer period will start during the sensor read out and will finish sometime after it but it is not considered as part of the Frame.

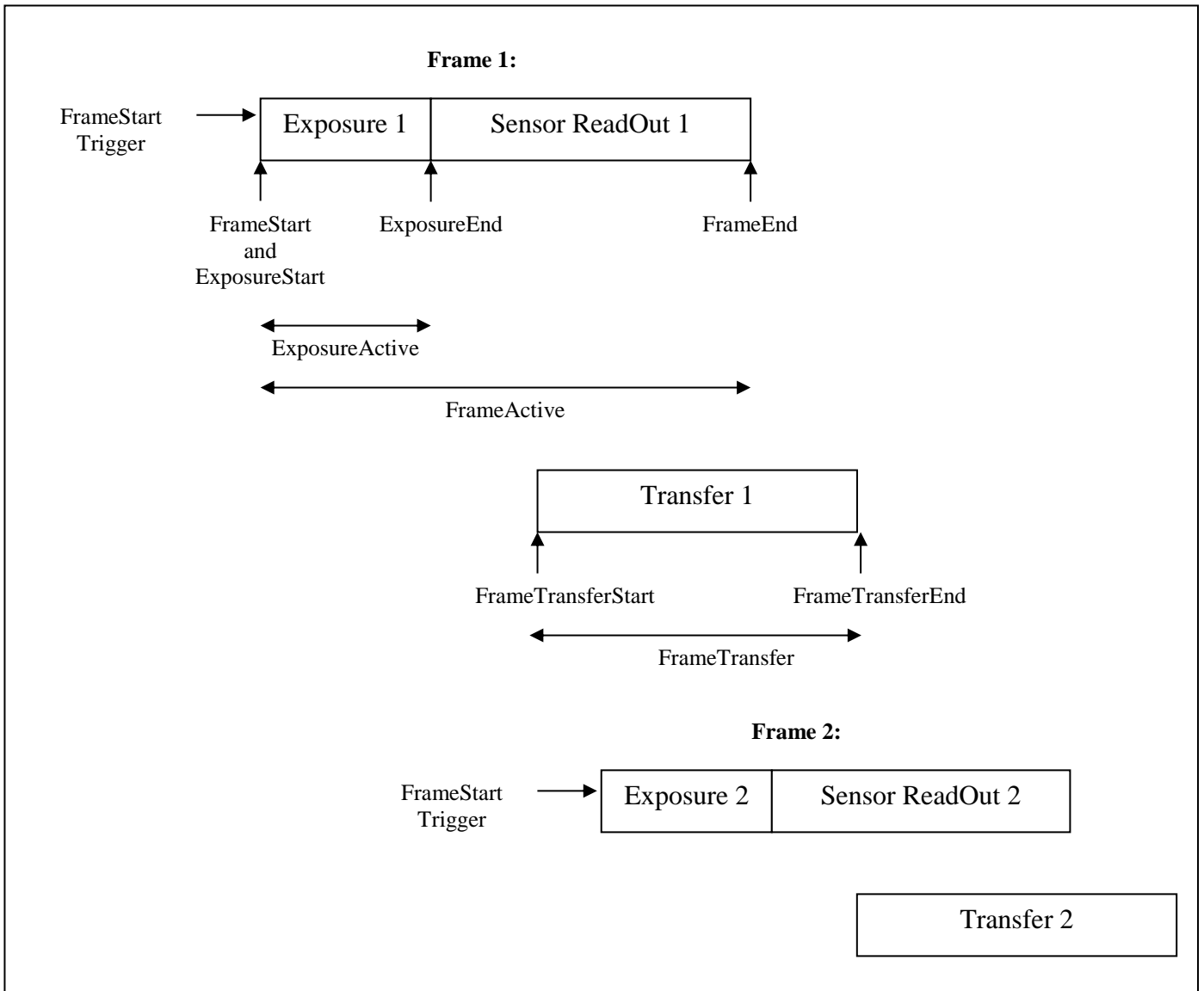

Figure 5-3: Frame signals definition

For Linescan acquisition, the definition of **Frame** stays the same but the exposure and read out are done for each line of the virtual Frame

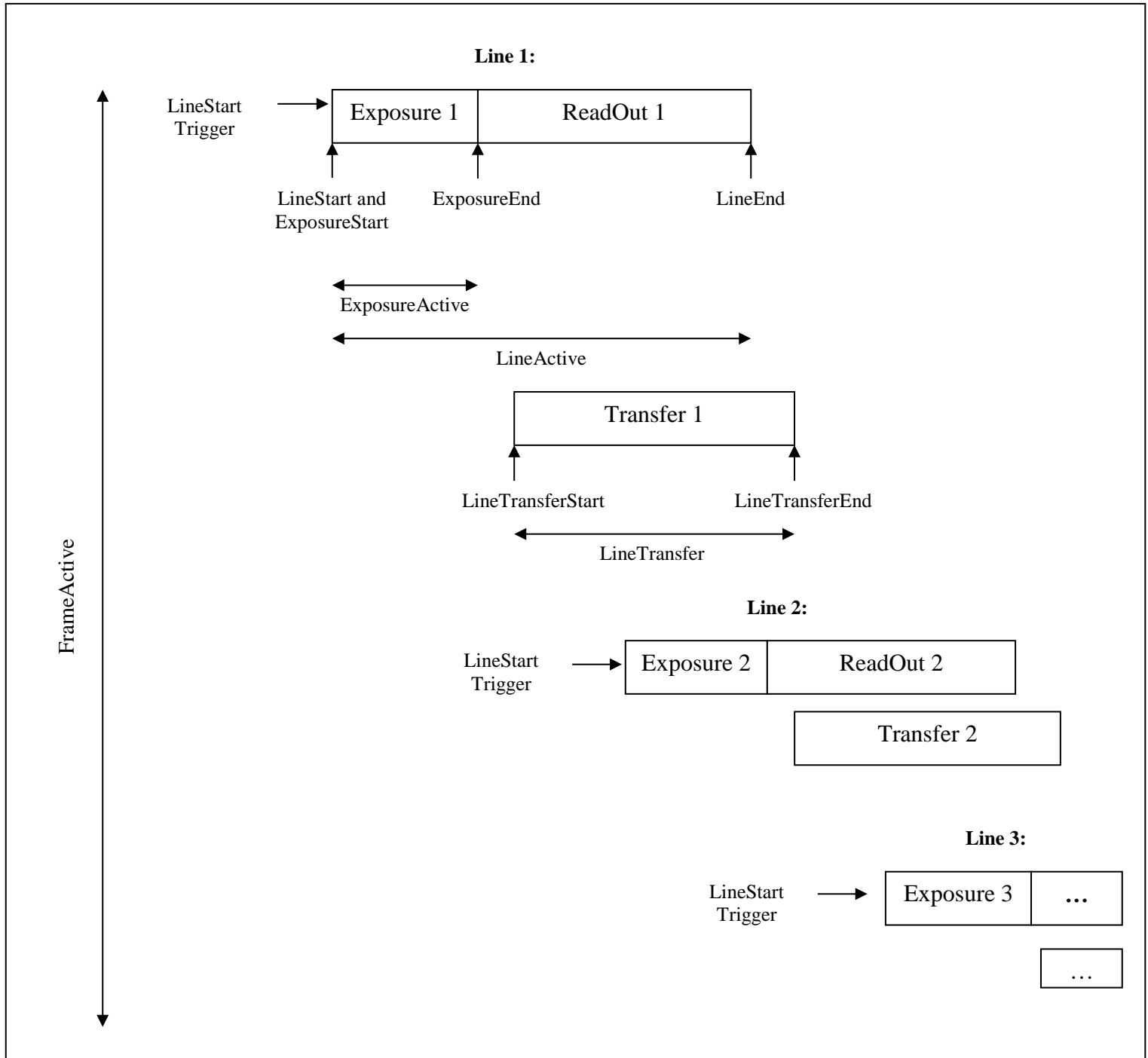

Figure 5-4: Frame signals definition in Linescan mode

5.2 Acquisition features usage model

The **AcquisitionMode** controls the mode of acquisition for the device. This mainly affects the number of frames captured in the Acquisition (**SingleFrame**, **MultiFrame** or **Continuous**).

The optional **AcquisitionArm** command is used to verify and freeze all parameters relevant for the image data capture. It prepares the device for the **AcquisitionStart**.

The **AcquisitionStart** command is used to start the Acquisition.

The **AcquisitionStop** command will stop the Acquisition at the end of the current Frame. It can be used in any acquisition mode and if the camera is waiting for a trigger, the pending Frame will be cancelled.

The **AcquisitionAbort** command can be used to abort an Acquisition at any time. This will end the capture immediately without completing the current Frame.

AcquisitionFrameCount controls the number of frames that will be captured when **AcquisitionMode** is **MultiFrame**.

AcquisitionBurstFrameCount determines the length of each burst to capture if the **FrameBurstStart** trigger is enabled and the **FrameBurstEnd** trigger is disabled.

AcquisitionFrameRate controls the rate at which the Frames are captured when **TriggerMode** is **Off**.

AcquisitionLineRate controls the rate at which the Lines in each Frame are captured when **TriggerMode** is **Off**. This is generally useful for linescan cameras.

AcquisitionStatusSelector and **AcquisitionStatus** can be used to read the status of the internal acquisition signals. The standard acquisition signals Status are: **AcquisitionTriggerWait**, **AcquisitionActive**, **AcquisitionTransfer**, **FrameTriggerWait**, **FrameActive**, **ExposureActive** (See Figure 5-1 and Figure 5-3).

5.3 Acquisition timing diagrams

This section gives the timing diagrams and features setting order for the most common acquisition scenarios.

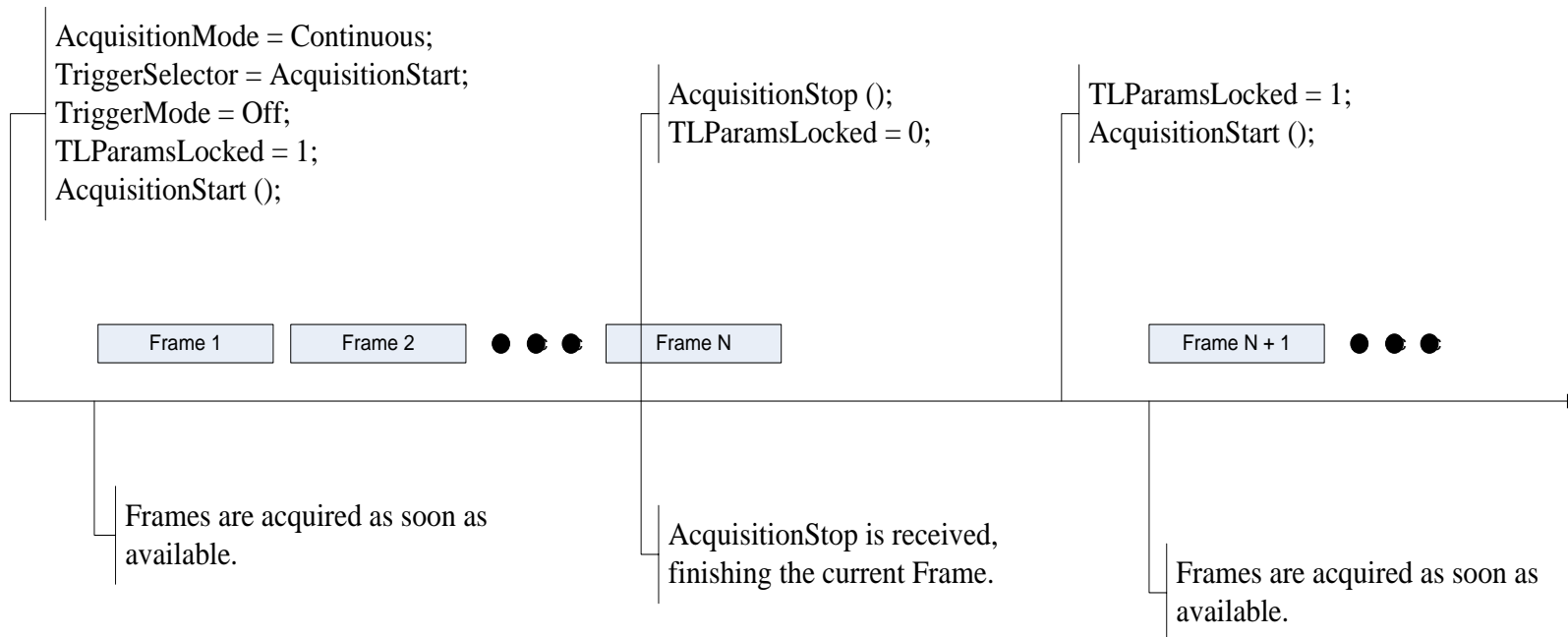

Figure 5-5: Continuous Acquisition

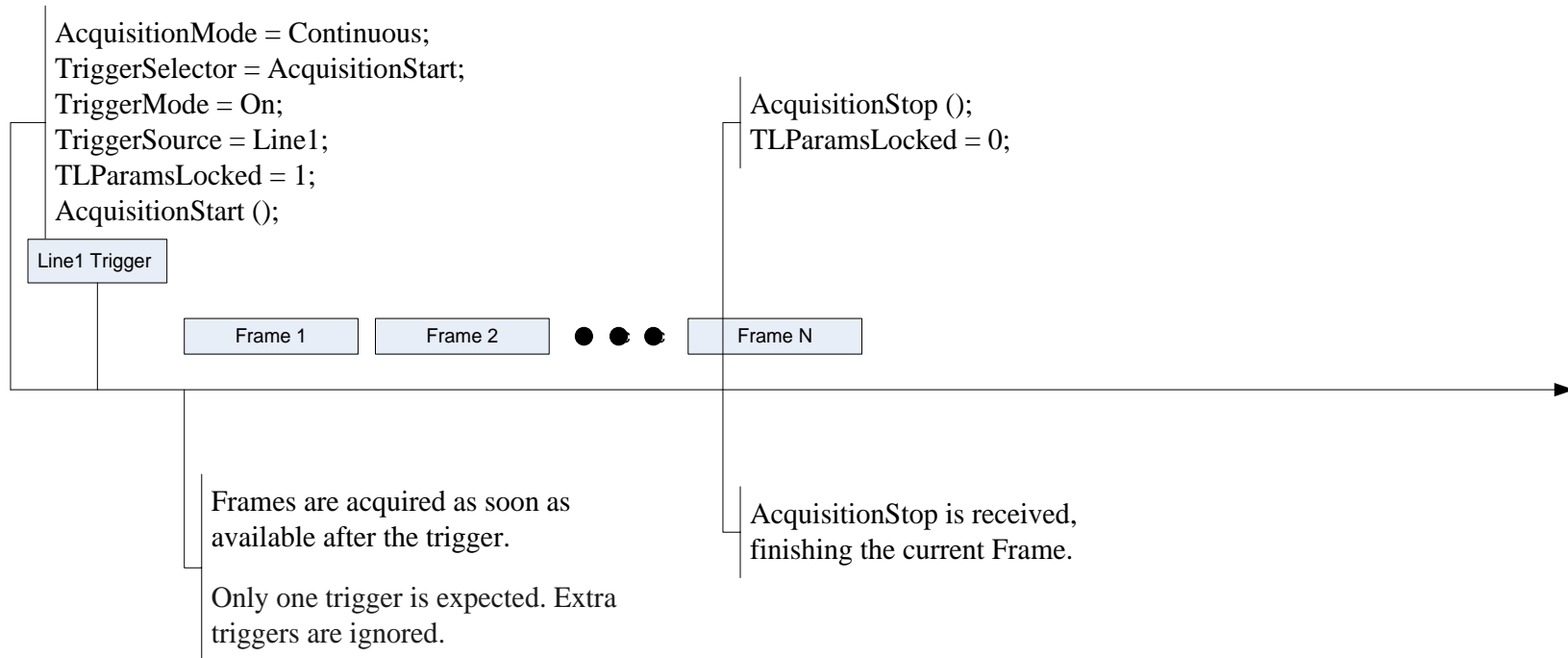

Figure 5-6: Continuous Acquisition with AcquisitionStart trigger

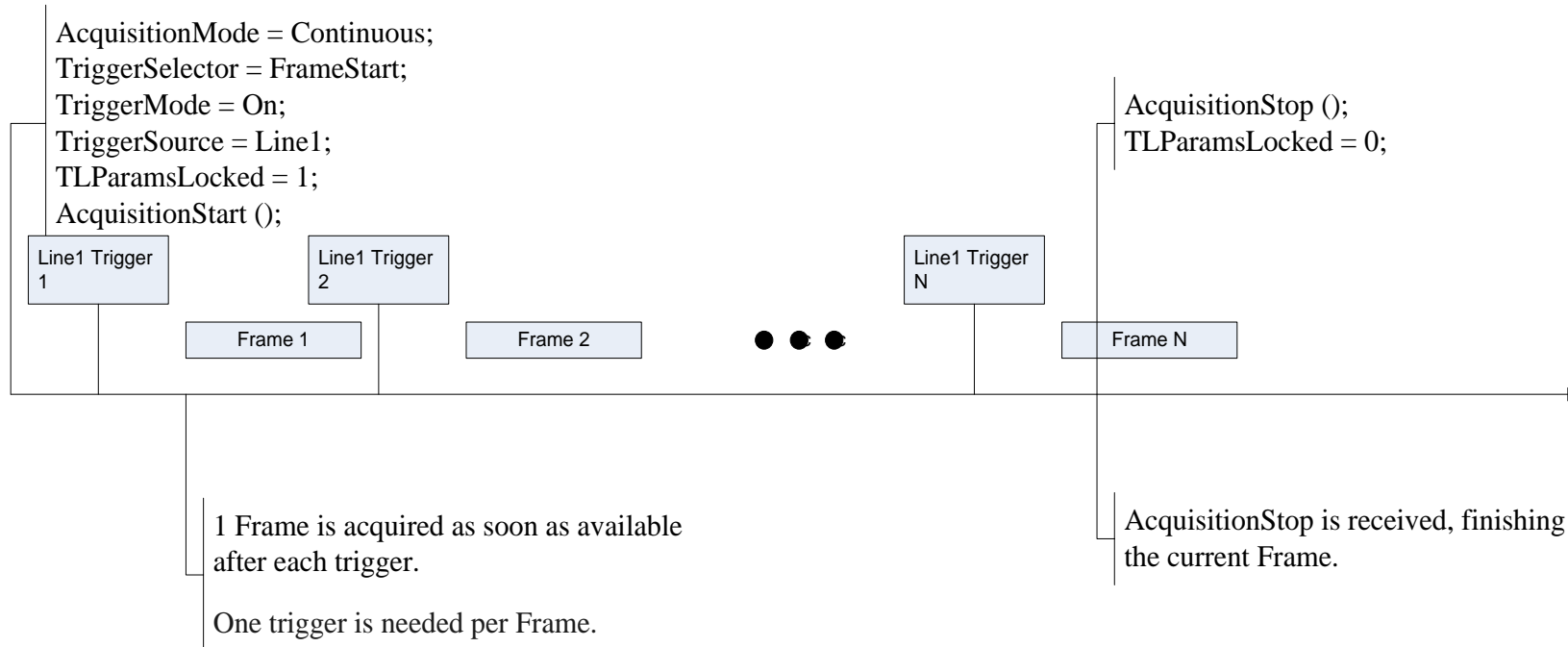

Figure 5-7: Continuous Acquisition with FrameStart trigger

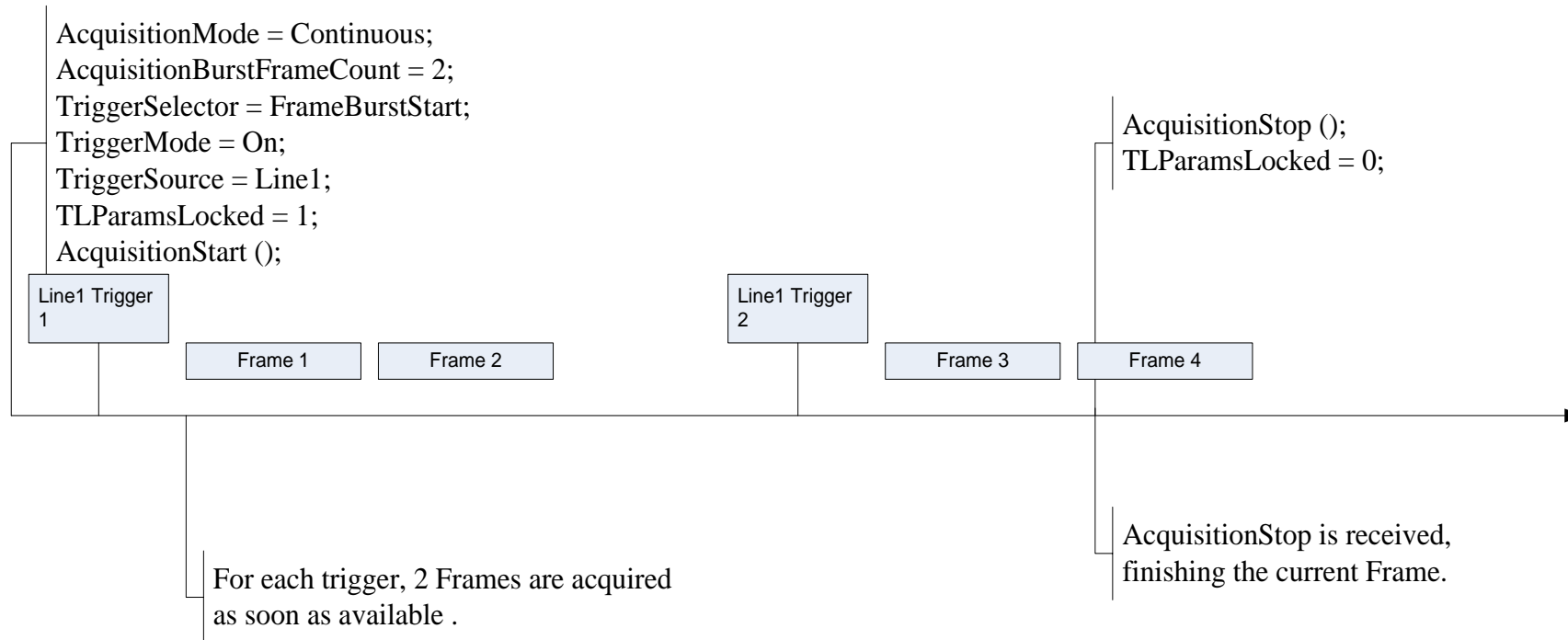

Figure 5-8: Continuous Acquisition with FrameBurstStart trigger

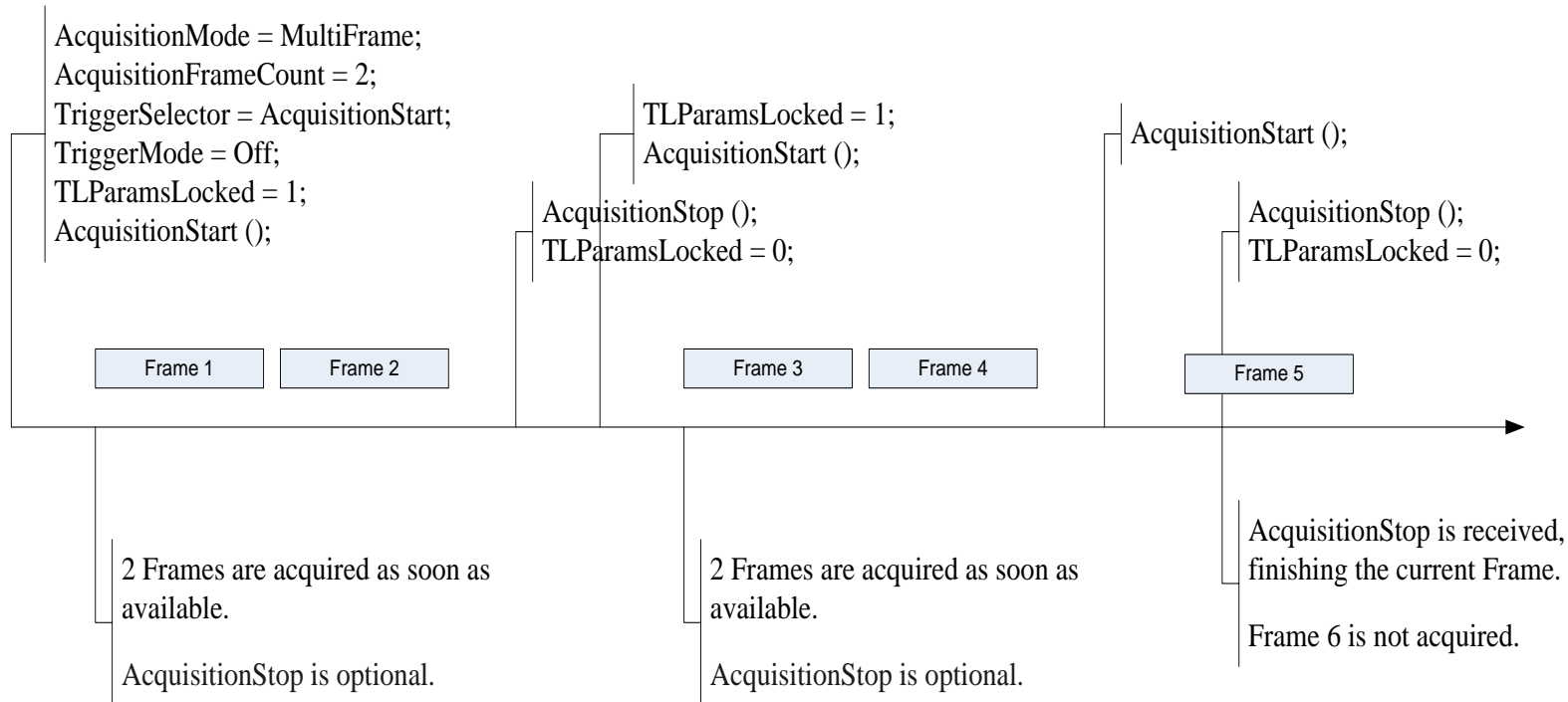

Figure 5-9: MultiFrame Acquisition

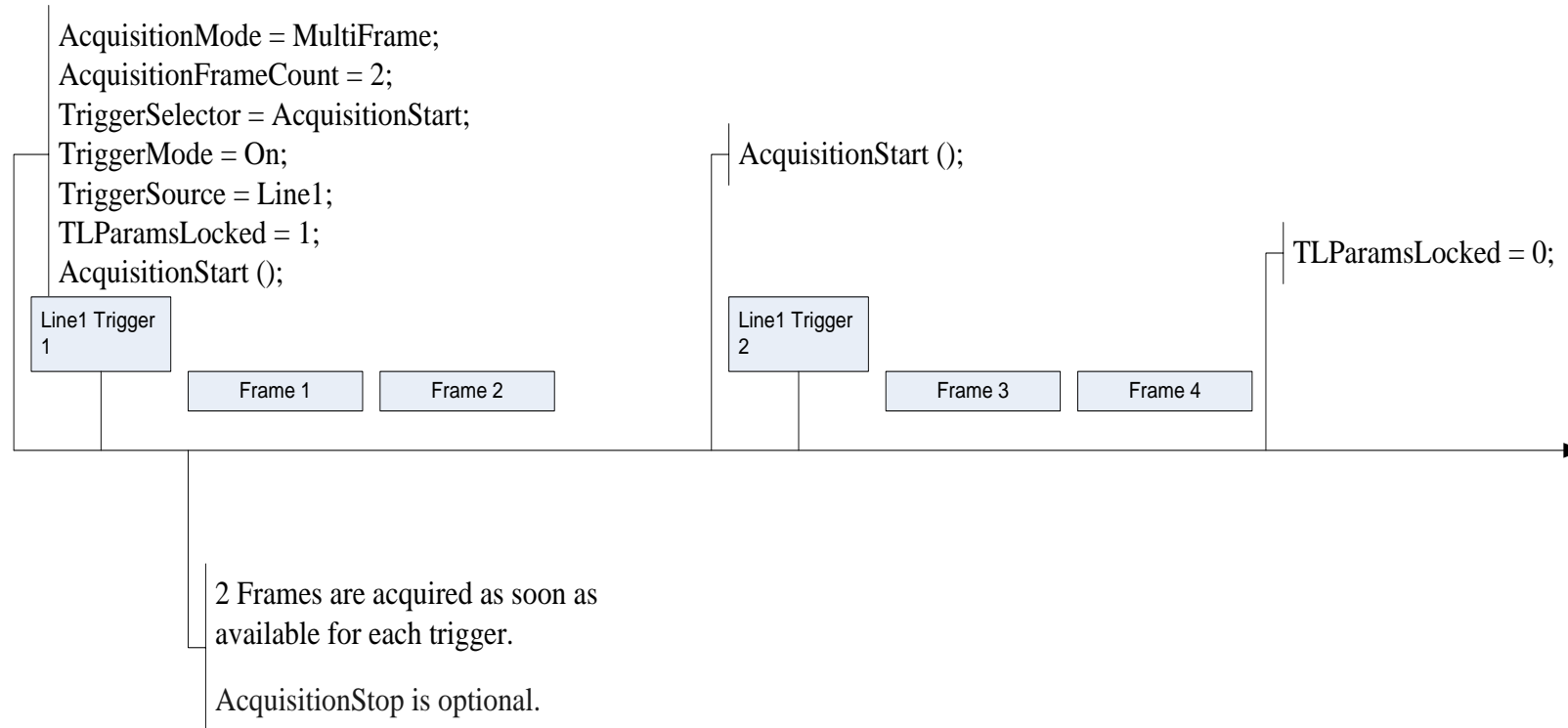

Figure 5-10: Multi Frame Acquisition with AcquisitionStart trigger

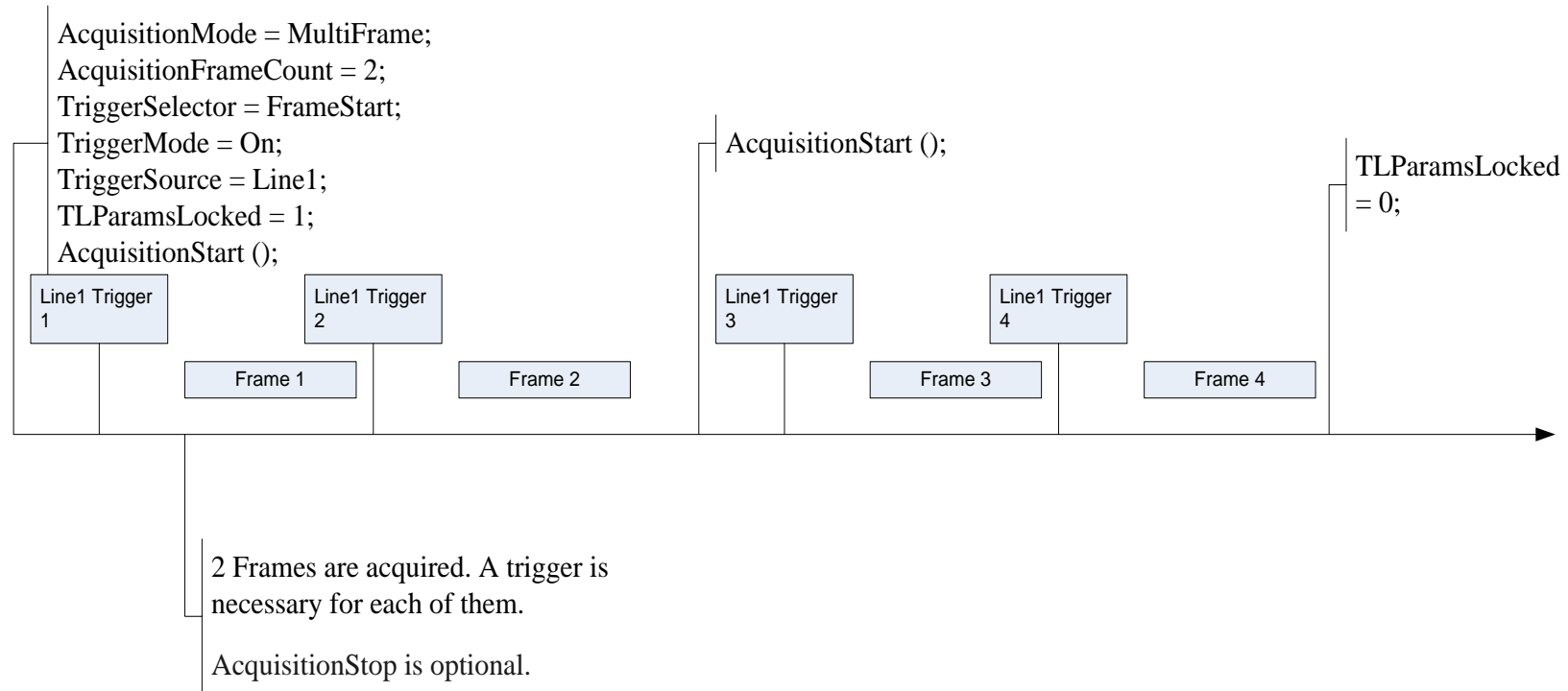

Figure 5-11: Multi Frame Acquisition with FrameStart trigger

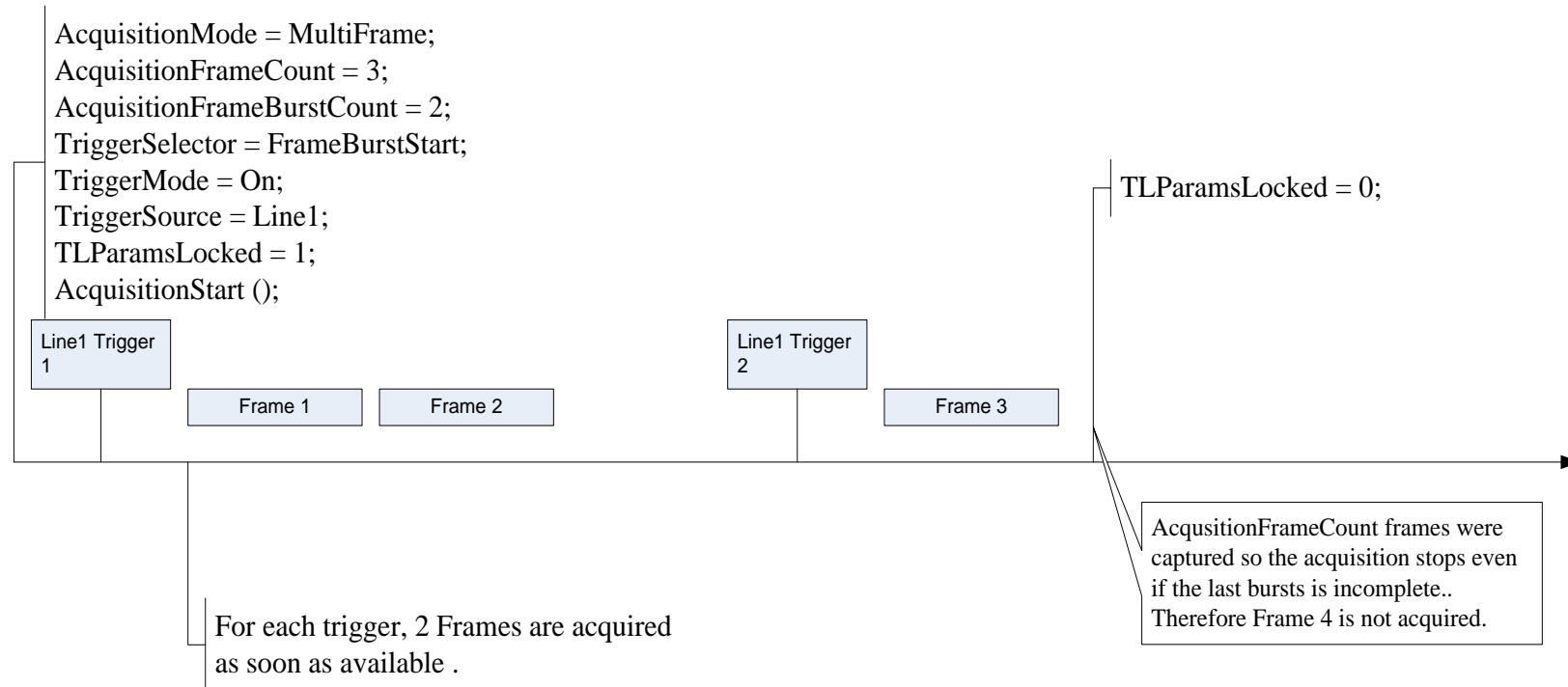

Figure 5-12: Multi Frame Acquisition with FrameBurstStart trigger

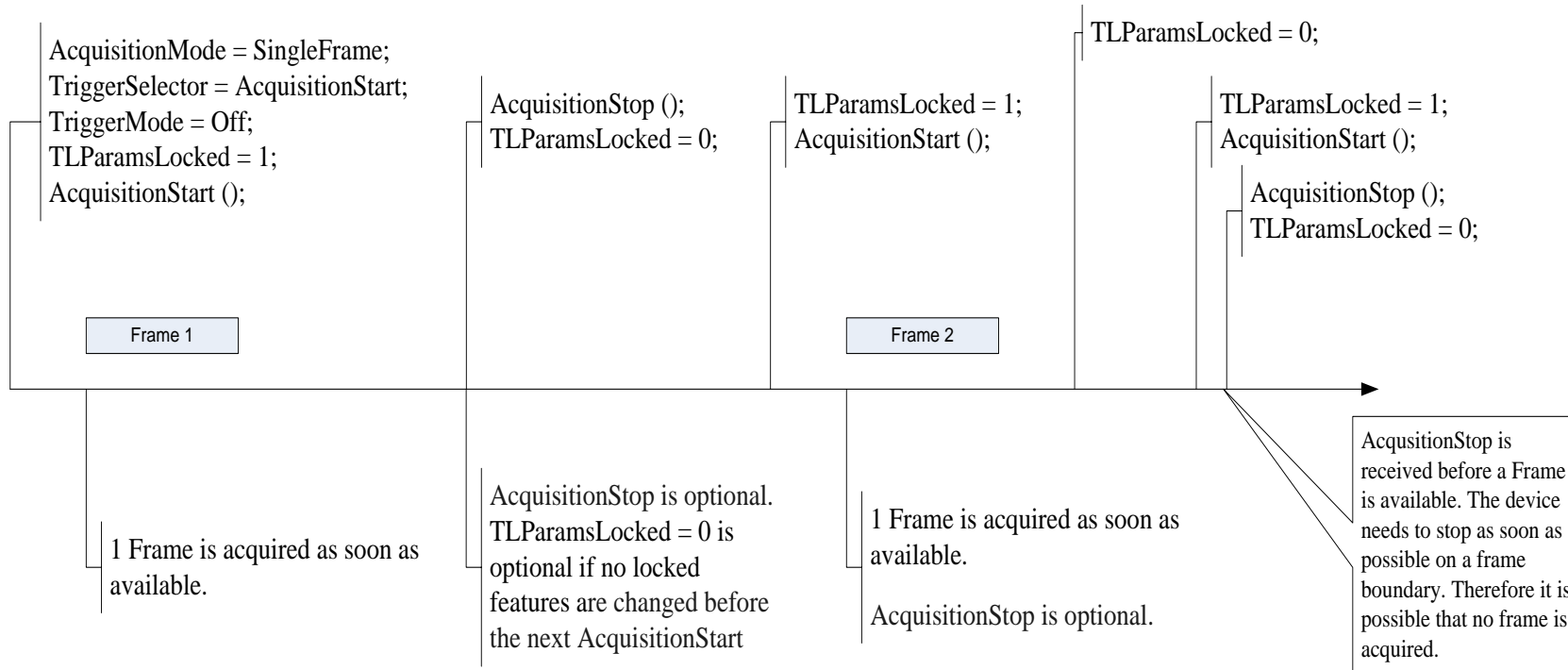

Figure 5-13: Single Frame Acquisition

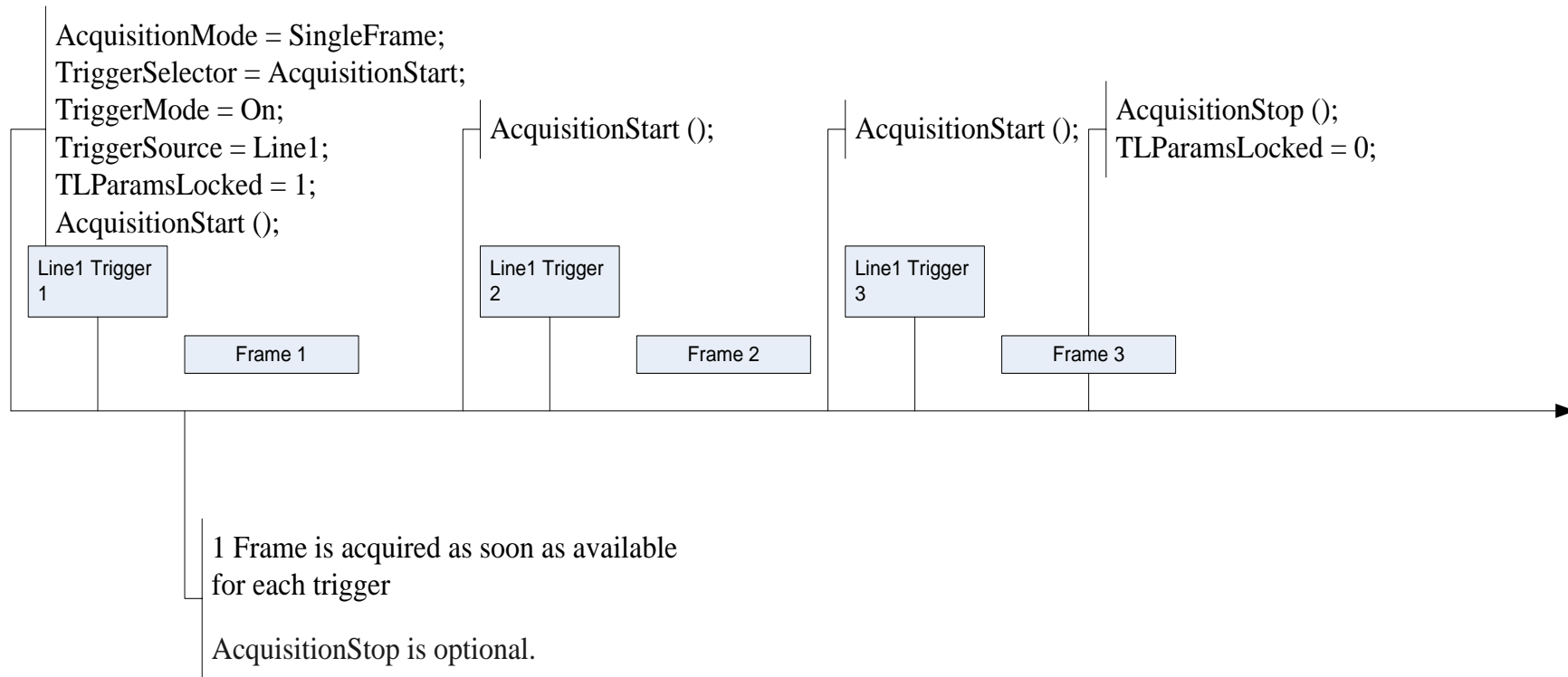

Figure 5-14: Single Frame Acquisition with AcquisitionStart trigger

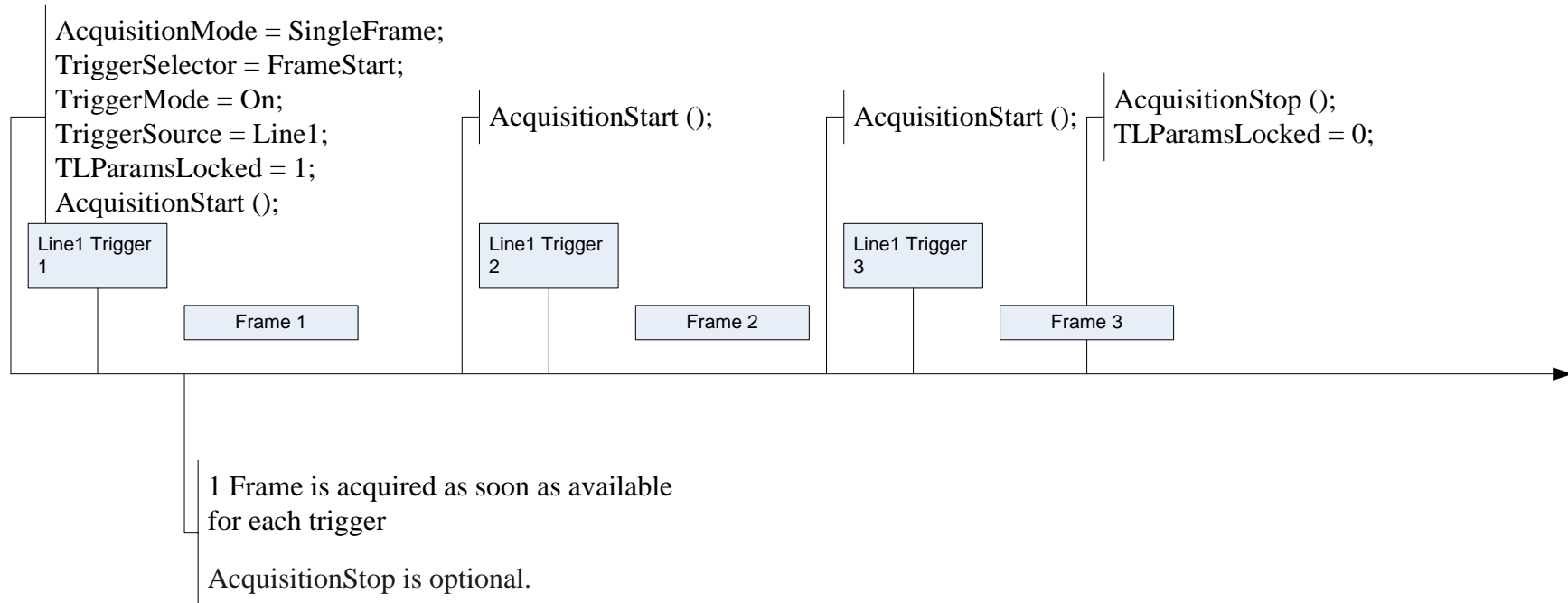

Figure 5-15: Single Frame Acquisition with FrameStart trigger

5.4 Acquisition and Trigger features usage examples

This section shows examples of typical use cases of acquisition and control of the SFNC features in C/C++ pseudo-code.

For simplicity, the object name is omitted (e.g., **AcquisitionStart()** instead of **Camera.AcquisitionStart()**) and the default state of the camera is assumed (e.g. Ready for a continuous acquisition start without trigger).

/ Continuous acquisition when the camera is in its reset state. */*

```
AcquisitionMode = Continuous;
AcquisitionStart();
...
AcquisitionStop();
```

/ Single Frame acquisition in Hardware trigger mode using the external I/O Line 3. */*

```
AcquisitionMode    = SingleFrame;
TriggerSelector    = FrameStart;
TriggerMode        = On;
TriggerActivation  = RisingEdge;
TriggerSource      = Line3;
AcquisitionStart();
```

/* Multi-Frame acquisition started by a single Software trigger delayed by 1 millisecond.
The Trigger starts the whole sequence acquisition. The Exposure time for each frame is set to 500 us.

*/

```
AcquisitionMode      = MultiFrame;
AcquisitionFrameCount = 20;
TriggerSelector      = AcquisitionStart;
TriggerMode          = On;
TriggerSource         = Software;
TriggerDelay         = 1000;

ExposureMode         = Timed;
ExposureTime         = 500;

AcquisitionStart();
TriggerSoftware();
```

/* Continuous acquisition in Hardware trigger mode. The Frame triggers are Rising Edge signals coming from the physical Line 2. The Exposure time is 500us. An exposure end event is also sent to the Host application after the exposure of each frame to signal that the inspected part can be moved. The timestamp of the event is also read.

*/

```
AcquisitionMode      = Continuous;
TriggerSelector      = FrameStart;
TriggerMode          = On;
TriggerActivation    = RisingEdge;
TriggerSource         = Line2;

ExposureMode         = Timed;
ExposureTime         = 500;

Register(Camera.EventExposureEnd, CallbackDataObject, CallbackFunctionPtr)
EventSelector        = ExposureEnd;
EventNotification    = On;

AcquisitionStart();

...

// In the callback of the ExposureEnd event, get the event timestamp:
Timestamp = EventExposureEndTimestamp;

...

AcquisitionStop();
```

/* Multi-Frame acquisition with each frame triggered by a Hardware trigger on Line 1.
A negative pulse of the exposure signal duration (500us) is also sent to the physical

output line 2 to activate a light during the exposure time of each frame. The end of the sequence capture is signalled to the host with an acquisition end event.

*/

```
AcquisitionMode      = MultiFrame;
AcquisitionFrameCount = 20;

TriggerSelector      = FrameStart;
TriggerMode          = On;
TriggerActivation    = RisingEdge;
TriggerSource        = Line1;

ExposureMode         = Timed;
ExposureTime         = 500;

LineSelector         = Line2;
LineMode             = Output;
LineInverter         = True;
LineSource           = ExposureActive

Register(Camera.EventAcquisitionEnd, CallbackDataObject, CallbackFunctionPtr)
EventSelector        = AcquisitionEnd;
EventNotification    = On;
AcquisitionStart();
```

/* Continuous Acquisition of frames in bursts of 10 frames. Each burst is triggered by a Hardware trigger on Line 1. The end of each burst capture is signalled to the host with a FrameBurstEnd event.

*/

```
AcquisitionMode          = Continuous;
AcquisitionBurstFrameCount = 10;

TriggerSelector          = FrameBurstStart;
TriggerMode              = On;
TriggerActivation        = RisingEdge;
TriggerSource            = Line1;

Register (Camera.EventFrameBurstEnd, CallbackDataObject, CallbackFunctionPtr)

EventSelector            = FrameBurstEnd;
EventNotification        = On;

AcquisitionStart();

...

// In the callback of the end of burst event, get the event timestamp:
Timestamp = EventExposureEndTimestamp;

...

AcquisitionStop();
```

/* Multi-Frame Acquisition of 50 frames in 5 bursts of 10 frames. Each burst is triggered by a Hardware trigger on Line 1.

*/

```
AcquisitionMode          = MultiFrame;
AcquisitionFrameCount    = 50;
AcquisitionBurstFrameCount = 10;

TriggerSelector          = FrameBurstStart;
TriggerMode              = On;
TriggerActivation        = RisingEdge;
TriggerSource            = Line1;

AcquisitionStart();
```

```
/* Linescan continuous acquisition with Hardware Frame and Line trigger. */
```

```
AcquisitionMode      = Continuous;
TriggerSelector      = FrameStart;
TriggerMode          = On;
TriggerActivation    = RisingEdge;
TriggerSource        = Line1;
TriggerSelector      = LineStart;
TriggerMode          = On;
TriggerActivation    = RisingEdge;
TriggerSource        = Line2;

AcquisitionStart();
...
AcquisitionStop();
```

```
/* Framescan continuous acquisition with Hardware Frame trigger and the
   Exposure duration controlled by the Trigger pulse width.
```

```
*/
```

```
AcquisitionMode      = Continuous;
TriggerSelector      = FrameStart;
TriggerMode          = On;
TriggerActivation    = RisingEdge;
TriggerSource        = Line1;

ExposureMode         = TriggerWidth;

AcquisitionStart();
...
AcquisitionStop();
```

/* Framescan continuous acquisition with 1 Hardware trigger controlling the start of the acquisition and 2 others hardware triggers to start and stop the exposure of each frame.

*/

```
AcquisitionMode = Continuous;
TriggerSelector = AcquisitionStart;
TriggerMode     = On;
TriggerSource   = Line1;

ExposureMode    = TriggerControlled;
TriggerSelector = ExposureStart;

TriggerMode     = On;
TriggerSource   = Line3;
TriggerSelector = ExposureStop;
TriggerMode     = On;
TriggerSource   = Line4;

AcquisitionStart();
...
AcquisitionStop();
```

5.5 Acquisition Control features

This section gives the detailed description of all the Acquisition related features.

5.5.1 AcquisitionControl

Name	AcquisitionControl
Category	Root
Level	Recommended
Interface	ICategory
Access	Read
Unit	-
Visibility	Beginner
Values	-

Category for the acquisition and trigger control features.

5.5.2 AcquisitionMode

Name	AcquisitionMode
Category	AcquisitionControl
Level	Recommended
Interface	IEnumeration
Access	Read/(Write)
Unit	-
Visibility	Beginner
Values	SingleFrame MultiFrame Continuous

Sets the acquisition mode of the device. It defines mainly the number of frames to capture during an acquisition and the way the acquisition stops.

Possible values are:

- **SingleFrame**: One frame is captured.
- **MultiFrame**: The number of frames specified by **AcquisitionFrameCount** is captured.
- **Continuous**: Frames are captured continuously until stopped with the **AcquisitionStop** command.

This feature is generally mandatory for transmitters and transceivers of most Transport Layers.

5.5.3 AcquisitionStart

Name	AcquisitionStart
Category	AcquisitionControl
Level	Recommended
Interface	ICommand
Access	(Read)/Write
Unit	-
Visibility	Beginner
Values	-

Starts the Acquisition of the device. The number of frames captured is specified by **AcquisitionMode**.

The Acquisition might be conditioned by various triggers (See the **Trigger...** features). An AcquisitionStart command must be sent to the device before the acquisition related triggers become effective.

Note that unless the **AcquisitionArm** was executed since the last feature change, the **AcquisitionStart** command must validate all the current features for consistency before starting the Acquisition. This validation will not be repeated for the subsequent acquisitions unless a feature is changed in the device.

If the AcquisitionStart feature is currently not writable (locked), the application must not start the acquisition and must avoid using the feature until the feature becomes writable again.

This feature is generally mandatory for transmitters and transceivers of most Transport Layers.

5.5.4 AcquisitionStop

Name	AcquisitionStop
Category	AcquisitionControl
Level	Recommended
Interface	ICommand
Access	(Read)/Write
Unit	-
Visibility	Beginner
Values	-

Stops the Acquisition of the device at the end of the current Frame. It is mainly used when **AcquisitionMode** is **Continuous** but can be used in any acquisition mode.

If the camera is waiting for a trigger, the pending Frame will be cancelled. If no Acquisition is in progress, the command is ignored.

This feature is generally mandatory for transmitters and transceivers of most Transport Layers.

5.5.1 AcquisitionStopMode

Name	AcquisitionStopMode
Category	AcquisitionControl
Level	Optional
Interface	IEnum
Access	Read/Write
Unit	-
Visibility	Expert
Values	Complete Immediate

ImmediateWithPadding

Controls how the AcquisitionStop command and the acquisition stopped using a trigger (e.g. AcquisitionActive, FrameBurstActive, FrameActive or FrameEnd trigger), ends an ongoing frame. This feature is mainly used in Linescan devices where each line in a frame is acquired sequentially.

- Complete:** When stopped during a frame, the device will continue acquisition of lines until the specified Height is reached to deliver a complete default size frame.
Note that if each line is triggered from an external source and this line trigger stops no frame is delivered, and an AcquisitionAbort is needed.
- Immediate:** Acquisition stops immediately even during a frame and only the lines acquired at the time are delivered.
- ImmediateWithPadding:** Acquisition stops immediately even during a frame but the remaining of the frame will be padded with data to deliver a complete default Height frame.
Note: How the receiver knows which data is valid is beyond the scope of this feature, it can for example be done using chunk information.

5.5.2 AcquisitionAbort

Name	AcquisitionAbort
Category	AcquisitionControl
Level	Recommended
Interface	ICommand
Access	(Read)/Write
Unit	-
Visibility	Expert
Values	-

Aborts the Acquisition immediately. This will end the capture without completing the current Frame or waiting on a trigger. If no Acquisition is in progress, the command is ignored.

5.5.3 AcquisitionArm

Name	AcquisitionArm
Category	AcquisitionControl
Level	Optional
Interface	ICommand
Access	(Read)/Write

Unit	-
Visibility	Expert
Values	-

Arms the device before an **AcquisitionStart** command. This optional command validates all the current features for consistency and prepares the device for a fast start of the Acquisition.

If not used explicitly, this command will be automatically executed at the first **AcquisitionStart** but will not be repeated for the subsequent ones unless a feature is changed in the device.

5.5.4 AcquisitionFrameCount

Name	AcquisitionFrameCount
Category	AcquisitionControl
Level	Recommended
Interface	IInteger
Access	Read/Write
Unit	-
Visibility	Beginner
Values	≥ 1

Number of frames to acquire in MultiFrame Acquisition mode.

5.5.5 AcquisitionBurstFrameCount

Name	AcquisitionBurstFrameCount
Category	AcquisitionControl
Level	Optional
Interface	IInteger
Access	Read/Write
Unit	-
Visibility	Beginner
Values	≥ 1

Number of frames to acquire for each FrameBurstStart trigger.

This feature is used only if the FrameBurstStart trigger is enabled and the FrameBurstEnd trigger is disabled. Note that the total number of frames captured is also conditioned by AcquisitionFrameCount if AcquisitionMode is MultiFrame and ignored if AcquisitionMode is Single.

5.5.6 AcquisitionFrameRate

Name	AcquisitionFrameRate
Category	AcquisitionControl
Level	Recommended
Interface	IFloat
Access	Read/Write
Unit	Hz
Visibility	Beginner
Values	Device-specific

Controls the acquisition rate (in Hertz) at which the frames are captured.

TriggerMode must be **Off** for the Frame trigger.

5.5.7 AcquisitionFrameRateEnable

Name	AcquisitionFrameRateEnable
Category	AcquisitionControl
Level	Recommended
Interface	IBoolean
Access	Read/Write
Unit	-
Visibility	Expert
Values	True False

Controls if the AcquisitionFrameRate feature is writable and used to control the acquisition rate. Otherwise, the acquisition rate is implicitly controlled by the combination of other features like ExposureTime, etc...

5.5.8 AcquisitionLineRate

Name	AcquisitionLineRate
-------------	---------------------

Category	AcquisitionControl
Level	Recommended
Interface	IFloat
Access	Read/Write
Unit	Hz
Visibility	Beginner
Values	Device-specific

Controls the rate (in Hertz) at which the Lines in a Frame are captured.

TriggerMode must be **Off** for the Line trigger.

This is generally useful for linescan camera only.

5.5.9 AcquisitionLineRateEnable

Name	AcquisitionLineRateEnable
Category	AcquisitionControl
Level	Recommended
Interface	IBoolean
Access	Read/Write
Unit	-
Visibility	Expert
Values	True False

Controls if the AcquisitionLineRate feature is writable and used to control the acquisition rate. Otherwise, the acquisition rate is implicitly controlled by the combination of other features like ExposureTime, etc...

5.5.10 AcquisitionStatusSelector

Name	AcquisitionStatusSelector
Category	AcquisitionControl
Level	Recommended
Interface	IEnumeration

Access	Read/Write
Unit	-
Visibility	Expert
Values	AcquisitionTriggerWait AcquisitionActive AcquisitionTransfer FrameTriggerWait FrameActive ExposureActive FrameTransfer (Deprecated)

Selects the internal acquisition signal to read using AcquisitionStatus.

See Figure 5-1 and Figure 5-3 for details.

Possible values are:

- **AcquisitionTriggerWait:** Device is currently waiting for a trigger for the capture of one or many frames.
- **AcquisitionActive:** Device is currently doing an acquisition of one or many frames.
- **AcquisitionTransfer:** Device is currently transferring an acquisition of one or many frames.
- **FrameTriggerWait:** Device is currently waiting for a frame start trigger.
- **FrameActive:** Device is currently doing the capture of a frame.
- **ExposureActive:** Device is doing the exposure of a frame.
- **FrameTransfer (Deprecated):** See TransferStatus.

5.5.11 AcquisitionStatus

Name	AcquisitionStatus[AcquisitionStatusSelector]
Category	AcquisitionControl
Level	Recommended
Interface	IBoolean
Access	Read
Unit	-
Visibility	Expert
Values	True False

Reads the state of the internal acquisition signal selected using **AcquisitionStatusSelector**.

5.6 Trigger Control features

The Trigger Control section describes all features related to image acquisition using trigger(s).

One or many **Trigger**(s) can be used to control the start of an **Acquisition** (Figure 5-1), of a **Burst of Frames** (Figure 5-2), of individual **Frames** (Figure 5-3) or of each **Line** of a Frame for a device (Figure 5-4). **Triggers** can also be used to control the exposure duration at the beginning of a frame.

TriggerSelector is used to select which type of trigger to configure. The standard trigger types are: **AcquisitionStart**, **AcquisitionEnd**, **AcquisitionActive**, **FrameBurstStart**, **FrameBurstEnd**, **FrameBurstActive**, **FrameStart**, **FrameEnd**, **FrameActive**, **LineStart**, **ExposureStart**, **ExposureEnd** and **ExposureActive**.

TriggerMode activate/deactivate trigger operation. It can be **On** or **Off**.

TriggerSource specifies the physical input **Line** or internal signal to use for the selected trigger. Standard trigger sources are: **Software**, **Line0**, **Line1**, ..., **UserOutput0**, **UserOutput1**, ..., **Counter0Start**, **Counter0End**, ..., **Timer0Start**, **Timer0End**, , ..., **Encoder0**, **Encoder1**, ..., **LogicBlock0**, **LogicBlock1**, ..., **Action0**, **Action1**, ... , **LinkTrigger0**, **LinkTrigger1**, ...

With a **Software** trigger source, the **TriggerSoftware** command can be used by an application to generate an internal trigger signal.

With the hardware trigger sources, **TriggerActivation** specifies the activation mode of the trigger. This can be a **RisingEdge**, **FallingEdge**, **AnyEdge**, **LevelHigh** or **LevelLow**.

TriggerOverlap specifies the type of trigger overlap permitted with the previous frame/ line. This defines when a valid trigger will be accepted (or latched) for a new frame/line. This can be **Off** for no overlap, **ReadOut** to accept a trigger immediately after the exposure period or **PreviousFrame/PreviousLine** to accept (latch) a trigger that happened at any time after the start of the previous frame/Line. If a trigger is discarded based on the trigger overlap control and the current sensor state, it becomes a missed trigger. This represents an over-triggering situation and is typically considered as an error which can be connected to an Event.

TriggerDelay specifies the delay to apply after the trigger signal reception before effectively activating it.

TriggerDivider and **TriggerMultiplier** are used to control the ratio of triggers that are accepted.

Note that, a trigger is considered valid after the Dividers, Multipliers, Delay, ...

For example to setup a hardware triggered acquisition that will start the capture of each frame on the rising edge of the signal coming from the physical input Line 1, the following pseudo-code can be used:

```
Camera.TriggerSelector    = FrameStart;
Camera.TriggerMode       = On;
Camera.TriggerActivation  = RisingEdge;
Camera.TriggerSource     = Line1;
```

The drawing below shows the functional model of the trigger generation in SFNC.

It shows the order and the stages that an input signal received on an external line may pass to become a valid trigger (Ex: a FrameTrigger).

Note that the signal received on an external line or generated from an internal circuit is considered a valid trigger for the Acquisition section only after passing all those stages (if they re implemented).

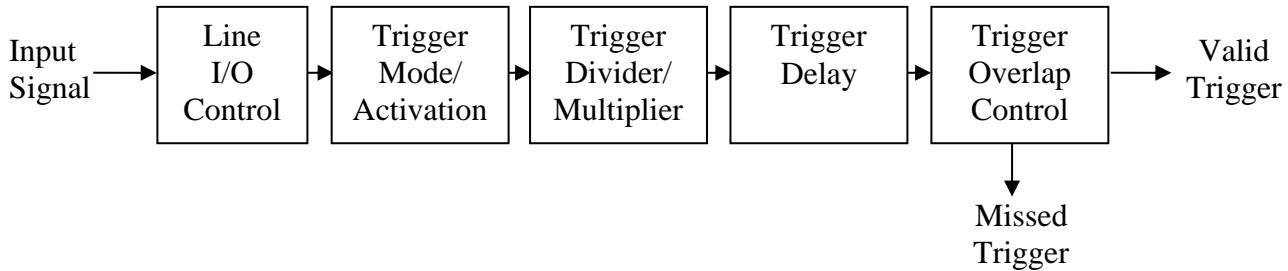

Figure 5-16: Trigger generation functional model.

- **Input Signal** represents an electrical signal received on an external Line or an internal signal.
- **Line I/O Control** represents the Line Control Block as described in the Figure 6-1.
- **Trigger Mode/Activation** represents the effect of the TriggerMode and TriggerActivation features.
- **Trigger Divider/Multiplier** represents the effect of the TriggerDivider and TriggerMultiplier features.
- **Trigger Delay** represents the effect of the TriggerDelay feature
- **Trigger Overlap Control** represents the effect of the TriggerOverlap feature.
- **Valid Trigger** represents when an incoming signal becomes a valid Trigger.
- **Missed Trigger** represents when an incoming signal does not become a valid Trigger.

5.6.1 TriggerSelector

Name	TriggerSelector
Category	AcquisitionControl
Level	Recommended
Interface	IEnumeration
Access	Read/Write
Unit	-
Visibility	Beginner
Values	AcquisitionStart AcquisitionEnd AcquisitionActive FrameStart FrameEnd

	FrameActive FrameBurstStart FrameBurstEnd FrameBurstActive LineStart ExposureStart ExposureEnd ExposureActive MultiSlopeExposureLimit1
--	--

Selects the type of trigger to configure.

See Figure 5-1 and Figure 5-3 for details.

Possible values are:

- **AcquisitionStart:** Selects a trigger that starts the Acquisition of one or many frames according to **AcquisitionMode**.
- **AcquisitionEnd:** Selects a trigger that ends the Acquisition of one or many frames according to **AcquisitionMode**.
- **AcquisitionActive:** Selects a trigger that controls the duration of the Acquisition of one or many frames. The Acquisition is activated when the trigger signal becomes active and terminated when it goes back to the inactive state.
- **FrameStart:** Selects a trigger starting the capture of one frame.
- **FrameEnd:** Selects a trigger ending the capture of one frame (mainly used in linescan mode).
- **FrameActive:** Selects a trigger controlling the duration of one frame (mainly used in linescan mode).
- **FrameBurstStart:** Selects a trigger starting the capture of the bursts of frames in an acquisition. **AcquisitionBurstFrameCount** controls the length of each burst unless a **FrameBurstEnd** trigger is active. The total number of frames captured is also conditioned by **AcquisitionFrameCount** if **AcquisitionMode** is **MultiFrame**.
- **FrameBurstEnd:** Selects a trigger ending the capture of the bursts of frames in an acquisition.
- **FrameBurstActive:** Selects a trigger controlling the duration of the capture of the bursts of frames in an acquisition.
- **LineStart:** Selects a trigger starting the capture of one Line of a Frame (mainly used in linescan mode).
- **ExposureStart:** Selects a trigger controlling the start of the exposure of one Frame (or Line).
- **ExposureEnd:** Selects a trigger controlling the end of the exposure of one Frame (or Line).
- **ExposureActive:** Selects a trigger controlling the duration of the exposure of one frame (or Line).
- **MultiSlopeExposureLimit1:** Selects a trigger controlling the first duration of a multi-slope exposure. Exposure is continued according to the pre-defined multi-slope settings.

5.6.2 TriggerMode

Name	TriggerMode[TriggerSelector]
Category	AcquisitionControl
Level	Recommended
Interface	IEnumeration
Access	Read/Write
Unit	-
Visibility	Beginner
Values	Off On

Controls if the selected trigger is active.

Possible values are:

- **Off:** Disables the selected trigger.
- **On:** Enable the selected trigger.

5.6.3 TriggerSoftware

Name	TriggerSoftware[TriggerSelector]
Category	AcquisitionControl
Level	Recommended
Interface	ICommand
Access	(Read)/Write
Unit	-
Visibility	Beginner
Values	-

Generates an internal trigger. **TriggerSource** must be set to **Software**.

5.6.4 TriggerSource

Name	TriggerSource[TriggerSelector]
Category	AcquisitionControl
Level	Recommended
Interface	IEnumeration

Access	Read/Write
Unit	-
Visibility	Beginner
Values	<p>Software SoftwareSignal0 (If 0 based), SoftwareSignal1, SoftwareSignal2, ... Line0 (If 0 based), Line1, Line2, ... UserOutput0, UserOutput1, UserOutput2, ... Counter0Start (If 0 based), Counter1Start, Counter2Start, ... Counter0End (If 0 based), Counter1End, Counter2End, ... Timer0Start (If 0 based), Timer1Start, Timer2Start, ... Timer0End (If 0 based), Timer1End, Timer2End, ... Encoder0 (If 0 based), Encoder1 , Encoder2, ... LogicBlock0 (If 0 based), LogicBlock1, LogicBlock2, ... Action0 (If 0 based), Action1, Action2, ... LinkTrigger0 (If 0 based), LinkTrigger1, LinkTrigger2, ... CC1, CC2, CC3, CC4, ...</p>

Specifies the internal signal or physical input **Line** to use as the trigger source. The selected trigger must have its **TriggerMode** set to **On**.

Possible values are:

- **Software**: Specifies that the trigger source will be generated by software using the **TriggerSoftware** command.
- **SoftwareSignal0, SoftwareSignal1, SoftwareSignal2, ...**: Specifies that the trigger source will be a signal generated by software using the **SoftwareSignalPulse** command.
- **Line0, Line1, Line2, ...**: Specifies which physical line (or pin) and associated I/O control block to use as external source for the trigger signal.
- **UserOutput0, UserOutput1, UserOutput2, ...**: Specifies which User Output bit signal to use as internal source for the trigger.

- **Counter0Start, Counter1Start, Counter2Start, ..., Counter0End, Counter1End, Counter2End, ...:** Specifies which of the Counter signal to use as internal source for the trigger.
- **Timer0Start, Timer1Start, Timer2Start, ..., Timer0End, Timer1End, Timer2End, ...:** Specifies which Timer signal to use as internal source for the trigger.
- **Encoder0, Encoder1, Encoder2, ...:** Specifies which Encoder signal to use as internal source for the trigger.
- **LogicBlock0, LogicBlock1, LogicBlock2, ...:** Specifies which Logic Block signal to use as internal source for the trigger.
- **Action0, Action1, Action2, ...:** Specifies which Action command to use as internal source for the trigger.
- **LinkTrigger0, LinkTrigger1, LinkTrigger2, ...:** Specifies which Link Trigger to use as source for the trigger (received from the transport layer).
- **CC1, CC2, CC3, CC4:** Index of the Camera Link physical line and associated I/O control block to use. This ensures a direct mapping between the lines on the frame grabber and on the camera. Applicable to CameraLink products only.

5.6.5 TriggerActivation

Name	TriggerActivation[TriggerSelector]
Category	AcquisitionControl
Level	Recommended
Interface	IEnumeration
Access	Read/Write
Unit	-
Visibility	Beginner
Values	RisingEdge FallingEdge AnyEdge LevelHigh LevelLow

Specifies the activation mode of the trigger.

Possible values are:

- **RisingEdge:** Specifies that the trigger is considered valid on the rising edge of the source signal.
- **FallingEdge:** Specifies that the trigger is considered valid on the falling edge of the source signal.
- **AnyEdge:** Specifies that the trigger is considered valid on the falling or rising edge of the source signal.

- **LevelHigh**: Specifies that the trigger is considered valid as long as the level of the source signal is high.
- **LevelLow**: Specifies that the trigger is considered valid as long as the level of the source signal is low.

5.6.6 TriggerOverlap

Name	TriggerOverlap[TriggerSelector]
Category	AcquisitionControl
Level	Recommended
Interface	IEnumeration
Access	Read/Write
Unit	-
Visibility	Expert
Values	Off ReadOut PreviousFrame PreviousLine

Specifies the type trigger overlap permitted with the previous frame or line. This defines when a valid trigger will be accepted (or latched) for a new frame or a new line.

Possible values are:

- **Off**: No trigger overlap is permitted.
- **ReadOut**: Trigger is accepted immediately after the exposure period.
- **PreviousFrame**: Trigger is accepted (latched) at any time during the capture of the previous frame.
- **PreviousLine**: Trigger is accepted (latched) at any time during the capture of the previous line.

5.6.7 TriggerDelay

Name	TriggerDelay[TriggerSelector]
Category	AcquisitionControl
Level	Recommended
Interface	IFloat
Access	Read/Write
Unit	us
Visibility	Expert
Values	Device-specific

Specifies the delay in microseconds (us) to apply after the trigger reception before activating it.

5.6.8 TriggerDivider

Name	TriggerDivider[TriggerSelector]
Category	AcquisitionControl
Level	Recommended
Interface	IInteger
Access	Read/Write
Unit	-
Visibility	Expert
Values	Device-specific

Specifies a division factor for the incoming trigger pulses.

5.6.9 TriggerMultiplier

Name	TriggerMultiplier[TriggerSelector]
Category	AcquisitionControl
Level	Recommended
Interface	IInteger
Access	Read/Write
Unit	-
Visibility	Expert
Values	Device-specific

Specifies a multiplication factor for the incoming trigger pulses. It is used generally used in conjunction with **TriggerDivider** to control the ratio of triggers that are accepted.

5.7 Exposure Control features

The Exposure Control section describes all features related to the exposure of the photosensitive cells (shutter control) during image acquisition.

The Exposure of the photosensitive cells during Frame or Line acquisition can be in 3 different modes.

- **ExposureMode** can be **Off** to disable the Shutter and let it open.

- **ExposureMode** can be **Timed** to have a timed exposure and allow programming the duration using the **ExposureTime** or **ExposureAuto** features.

For example to have a fixed exposure time of 1 millisecond, use the following pseudo code:

```
Camera.ExposureMode = Timed;
Camera.ExposureTime = 1000;
```

- **ExposureMode** can be **TriggerWidth** to use the width of the current Frame or Line trigger signal(s) to control exposure duration.
- **ExposureMode** can be **TriggerControlled** to use one or more trigger signal(s) to control the exposure duration independently from the current Frame or Line triggers (See **ExposureStart**, **ExposureEnd** and **ExposureActive** of the **TriggerSelector** feature).

For example: To use 2 hardware triggers respectively starting and stopping the Exposure, use the following pseudo code:

```
Camera.ExposureMode      = TriggerControlled;
Camera.TriggerSelector   = ExposureStart;
Camera.TriggerMode       = On;
Camera.TriggerSource     = Line1;
Camera.TriggerSelector   = ExposureEnd;
Camera.TriggerMode       = On;
Camera.TriggerSource     = Line2;
```

5.7.1 ExposureMode

Name	ExposureMode
Category	AcquisitionControl
Level	Recommended
Interface	IEnumeration
Access	Read/Write
Unit	-
Visibility	Beginner
Values	Off Timed TriggerWidth TriggerControlled

Sets the operation mode of the Exposure.

Possible values are:

- **Off:** Disables the Exposure and let the shutter open.
- **Timed:** Timed exposure. The exposure duration time is set using the `ExposureTime` or `ExposureAuto` features and the exposure starts with the `FrameStart` or `LineStart`.
- **TriggerWidth:** Uses the width of the current Frame or Line trigger signal(s) pulse to control the exposure duration. Note that if the Frame or Line **TriggerActivation** is `RisingEdge` or `LevelHigh`, the exposure duration will be the time the trigger stays High. If **TriggerActivation** is `FallingEdge` or `LevelLow`, the exposure time will last as long as the trigger stays Low.
- **TriggerControlled:** Uses one or more trigger signal(s) to control the exposure duration independently from the current Frame or Line triggers. See **ExposureStart**, **ExposureEnd** and **ExposureActive** of the **TriggerSelector** feature.

Note also that **ExposureMode** has priority over the Exposure Trigger settings defined using **TriggerSelector=Exposure...** and defines which trigger (if any) is active.

For example, if:

```
ExposureMode = Timed;
ExposureTime = 200;
```

Then the Exposure will be controlled using the **ExposureTime** Feature, even if the following code is done:

```
TriggerSelector = ExposureActive;
TriggerMode     = On;
TriggerActivation = LevelHigh;
TriggerSource   = Line1;
```

But simply by adding:

```
ExposureMode = TriggerControlled;
```

The Exposure duration will become controlled by the length of the positive pulse on physical Line 1.

5.7.2 ExposureTimeMode

Name	ExposureTimeMode
Category	AcquisitionControl
Level	Optional

Interface	IEnumeration
Access	Read/Write
Unit	-
Visibility	Beginner
Values	Common Individual

Sets the configuration mode of the **ExposureTime** feature.

The possible values for **ExposureTimeMode** are:

- **Common:** The exposure time is common to all the color components. The common **ExposureTime** value to use can be set selecting it with **ExposureTimeSelector[Common]**.
- **Individual:** The exposure time is individual for each color component. Each individual **ExposureTime** values to use can be set by selecting them with **ExposureTimeSelector**.

5.7.3 ExposureTimeSelector

Name	ExposureTimeSelector
Category	AcquisitionControl
Level	Optional
Interface	IEnumeration
Access	Read/Write
Unit	-
Visibility	Beginner
Values	Common Red Green Blue Cyan Magenta Yellow Infrared Ultraviolet Stage1 Stage2 ...

Selects which exposure time is controlled by the **ExposureTime** feature. This allows for independent control over the exposure components.

The possible values for **ExposureTimeSelector** are:

- **Common:** Selects the common ExposureTime.
- **Red:** Selects the red common ExposureTime.
- **Green:** Selects the green ExposureTime.
- **Blue:** Selects the blue ExposureTime.
- **Cyan:** Selects the cyan common ExposureTime.
- **Magenta:** Selects the magenta ExposureTime.
- **Yellow:** Selects the yellow ExposureTime.
- **Infrared:** Selects the infrared ExposureTime.
- **Ultraviolet:** Selects the ultraviolet ExposureTime.
- **Stage1:** Selects the first stage ExposureTime.
- **Stage2:** Selects the second stage ExposureTime.
- ...

5.7.4 ExposureTime

Name	ExposureTime[ExposureTimeSelector]
Category	AcquisitionControl
Level	Recommended
Interface	IFloat
Access	Read/Write
Unit	us
Visibility	Beginner
Values	≥ 0

Sets the Exposure time when **ExposureMode** is **Timed** and ExposureAuto is Off. This controls the duration where the photosensitive cells are exposed to light.

5.7.5 ExposureAuto

Name	ExposureAuto
Category	AcquisitionControl
Level	Optional
Interface	IEnumeration
Access	Read/Write

Unit	-
Visibility	Beginner
Values	Off Once Continuous Device-specific

Sets the automatic exposure mode when **ExposureMode** is **Timed**. The exact algorithm used to implement this control is device-specific.

Some other device-specific features might be used to allow the selection of the algorithm.

Possible values are:

- **Off**: Exposure duration is user controlled using **ExposureTime**.
- **Once**: Exposure duration is adapted once by the device. Once it has converged, it returns to the **Off** state.
- **Continuous**: Exposure duration is constantly adapted by the device to maximize the dynamic range.

On top of the previous standard values, a device might also provide device-specific values.

5.8 Multi-slope Exposure Control features

The Multi-slope exposure control section describes all features related to controlling the multiple phases of the exposure of the photosensitive cells during image acquisition.

To define a generic interface to an HDR feature also known as multi-slope or multi-knee-point or piecewise linear response, two slightly different models are considered:

- The pixels are reset to a specific level at a certain point in time.
- The pixel capacity is controlled and can be changed at a certain point in time.

Additionally, in both implementations, partial exposure times may be controlled separately.

Both models result in one image with a non-linear exposure characteristic composed of multiple, piecewise linear slopes. The points in graphs where the linear segments meet are generally named "knee-points".

To convert the parameters of the sensors to features, the following was considered:

- The number of knee-points differs from sensor to sensor.
- The number of used knee-points may be configured.
- All sensors allow adjusting the partial exposure times, but not necessarily the levels/capacities.
- Multi-slope exposure for HDR-like images requires different times for each part of the whole exposure.

- As a generalization, the threshold for a knee-point is determined in "percent" (of the currently available pixel capacity or of the currently available reset voltage - The currently available values might be influenced by the camera gain settings).
- As a further generalization, the unit for the sub-exposures is also "percent" (of the current exposure time).

For an explanation of the parameters involved in multi-slope exposure, two knee-points are assumed:

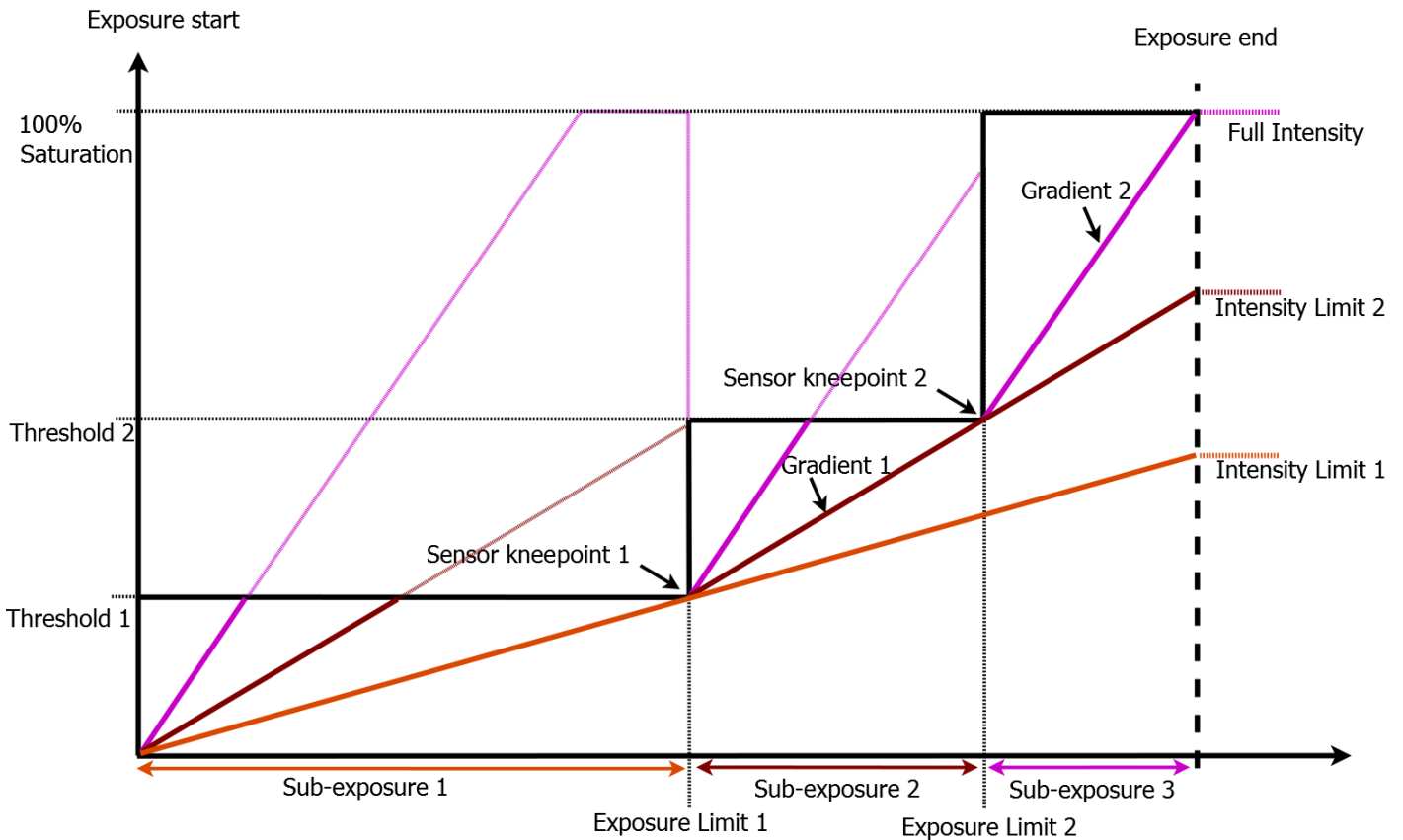

Figure 5-17: Multi-slope exposure model.

Exposure starts at a level of 0 percent saturation. After the first sub-exposure time, the pixels are only filled by $\langle \text{Threshold1} \rangle$ percent of the whole capacity. After the second sub-exposure time, the pixels are filled by $\langle \text{Threshold2} \rangle$ percent of the whole capacity. After the third sub-exposure time (which sums up to the total exposure time), exposure is stopped. To maintain the original meaning and behavior of feature **ExposureTime**, only the n limits between sub-exposures are used and not the $n+1$ sub-exposure times themselves; the last one results from **ExposureTime** and the other multi-slope exposure durations.

The result of this kind of exposure is shown in the next diagram:

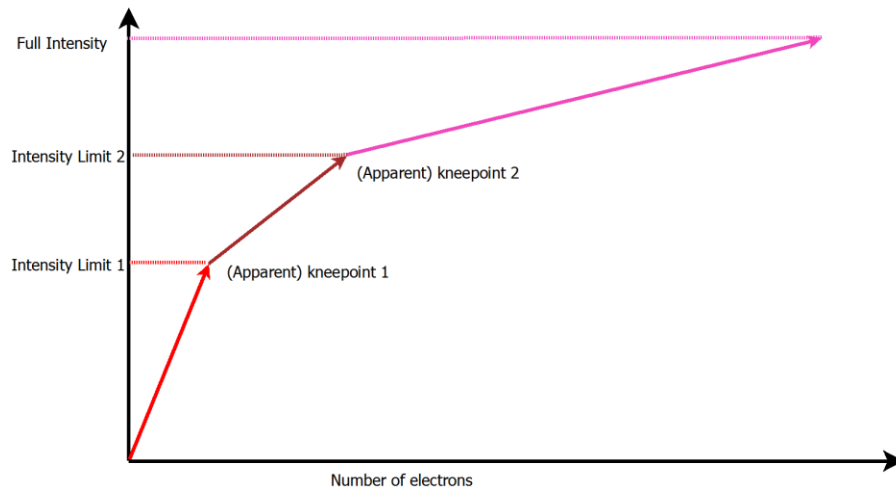

Figure 5-18: Multi-slope Intensity Limits.

The term "knee-point" can be found for either diagram and is determined by different parameters. Nevertheless, the sensor configuration for both knee-points is identical.

Triggering

Triggering is limited during multi-slope exposure since most of the functionality is handled in the sensor which must usually be pre-configured. Consequently, using **TriggerControlled** and **TriggerWidth ExposureMode** is not possible, and using **...End** triggers neither. Using **...Start** triggers is mainly possible.

Nevertheless, an additional trigger may be provided. A **MultiSlopeExposureLimit1** trigger invokes the first change in multi-slope exposure, using all the pre-defined knee-point settings and scaling them to the current length of the first sub-exposure.

Features

The number of knee-points for multi-slope exposure can be controlled with feature **MultiSlopeKneePointCount**.

Enabling multi-slope exposure is possible by setting feature **MultiSlopeMode** to either **Manual** or to one of the presets.

For **Manual** configuration, two parameters are necessary for each knee-point, selected by **MultiSlopeKneePointSelector**. The most obvious parameters are **MultiSlopeExposureLimit** for controlling the limits between the sub-exposure times, and **MultiSlopeSaturationThreshold** for the levels/capacities, if allowed by the sensor.

By controlling **MultiSlopeExposureLimit** in percent of the current **ExposureTime**, the concrete sub-exposure times adjacent to the selected knee-point are adjusted. Using percentage values allows changes of **ExposureTime** without changing the proportions of multi-slope exposure.

With the additional feature **MultiSlopeIntensityLimit**, you may directly observe or even control the limit between slopes in your intensity histogram, as will be shown in the next chapter.

With the additional feature **MultiSlopeExposureGradient**, you may directly observe or even control the gradient of an additional slope as seen in the Figure 5-17: Multi-slope exposure model.

Automatic configuration is also possible by selecting one of three values for **MultiSlopeMode**, **PresetSoft**, **PresetMedium**, and **PresetAggressive**.

Example

For illustration of the effects of multi-slope exposure, let's look at the consequences in an artificial illumination scene resulting in the following intensity histogram:



In this histogram (taken at an exemplary ExposureTime of 2000µs), many intensity values are not filled at all, and the ones that are filled are clustered around some spots. The goal of multi-slope exposure is a histogram that allows better segmentation of objects according to their intensity, while still keeping gradations in the bulk of intensities. In this case, two additional exposure slopes are chosen.

For defining multi-slope exposure, start with an exposure time that shows all the low-key intensities (in this example 10000µs), but with enough spare intensities to the right side to accommodate the high-key values that should now appear as top-value intensities like in the left diagram. This is the ExposureTime that you need for your result image.

Then define the parameters for the next slope to get the next intensities into the histogram, again leaving some space to the right (as can be seen in the right diagram).

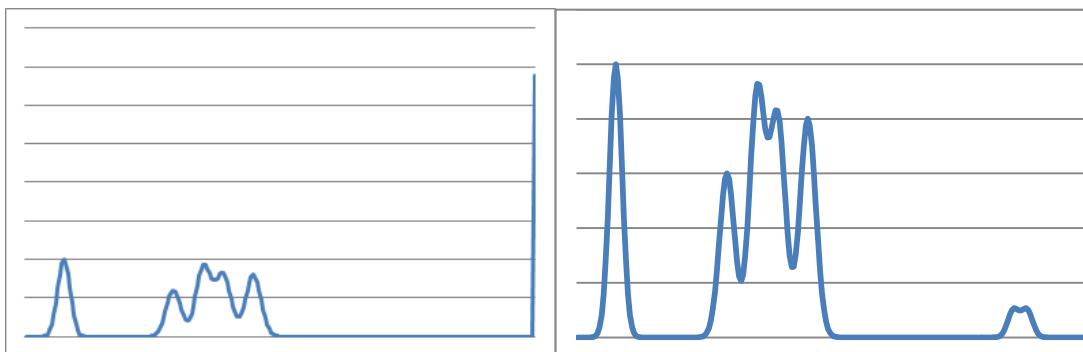

Finally, define the last slope to get also the highest keys into the histogram like in the following diagram :

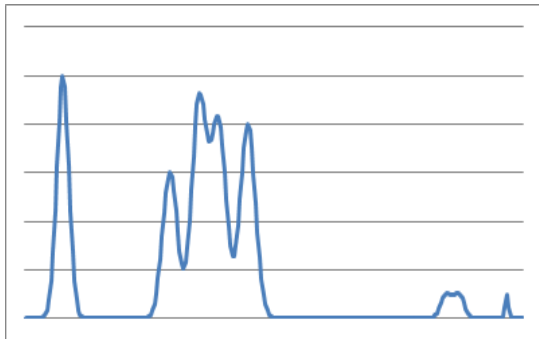

The overall effect may be summarized by the following transformation:

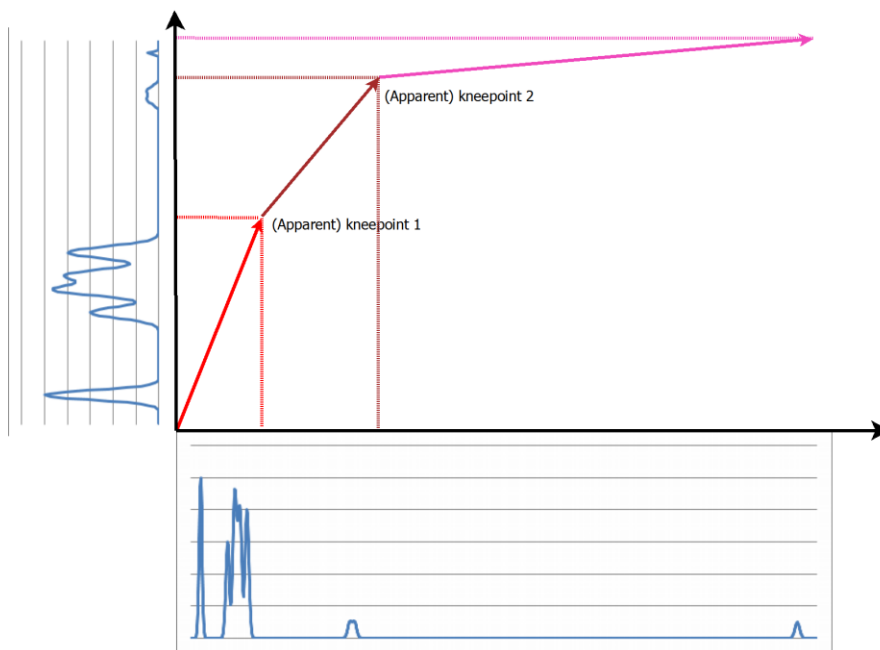

Figure 5-19: Multi-slope exposure example.

For the transformation of the shown diagrams, the following approximate parameters would apply:

MultiSlopeExposureLimit[1]=53,9%, MultiSlopeExposureLimit[2]=97,8%,

MultiSlopeSaturationThreshold[1]=28%, MultiSlopeSaturationThreshold[2]=88,9%.

This results in MultiSlopeIntensityLimit[1] of 52% and MultiSlopeIntensityLimit[2] of 92%, and an MultiSlopeExposureGradient[1] of 1.4 and MultiSlopeExposureGradient[2] of 5.

5.8.1 MultiSlopeMode

Name	MultiSlopeMode
Category	AcquisitionControl
Level	Optional
Interface	IEnumeration
Access	Read/Write
Unit	-
Visibility	Beginner
Values	Off Manual PresetSoft PresetMedium PresetAggressive

Controls multi-slope exposure state.

Possible values are:

- **Off:** Multi-slope exposure is disabled.
- **Manual:** Multi-slope exposure is enabled. Control is possible per knee-point with two of the features MultiSlopeExposureLimit, MultiSlopeSaturationThreshold, MultiSlopeIntensityLimit or MultiSlopeExposureGradient.
- **PresetSoft:** Multi-slope exposure is enabled. A predefined parameter set resulting in a soft effect is selected.
- **PresetMedium:** Multi-slope exposure is enabled. A predefined parameter set resulting in a medium effect is selected.
- **PresetAggressive:** Multi-slope exposure is enabled. A predefined parameter set resulting in an aggressive effect is selected.

5.8.2 MultiSlopeKneePointCount

Name	MultiSlopeKneePointCount
Category	AcquisitionControl
Level	Optional
Interface	IInteger
Access	Read/Write
Unit	-
Visibility	Expert

Values	1..n
---------------	------

The number of knee-points as well as the number of additional exposure slopes used for multi-slope exposure.

5.8.3 MultiSlopeKneePointSelector

Name	MultiSlopeKneePointSelector
Category	AcquisitionControl
Level	Optional
Interface	IInteger
Access	Read/Write
Unit	-
Visibility	Expert
Values	1..n

Selects the parameters for controlling an additional slope in multi-slope exposure.

5.8.4 MultiSlopeExposureLimit

Name	MultiSlopeExposureLimit[MultiSlopeKneePointSelector]
Category	AcquisitionControl
Level	Optional
Interface	IFloat
Access	Read/Write
Unit	%
Visibility	Expert
Values	0..100

Percent of the ExposureTime at a certain knee-point of multi-slope exposure.

5.8.5 MultiSlopeSaturationThreshold

Name	MultiSlopeSaturationThreshold[MultiSlopeKneePointSelector]
Category	AcquisitionControl
Level	Optional
Interface	IFloat
Access	Read/(Write)

Unit	%
Visibility	Expert
Values	0..100

The percentage of the full saturation that is applied at a certain knee-point of a multi-slope exposure.

The limits are sensor-specific and might not span the whole range of 0..100%.

In principle, setting this value to 100% would effectively disable this knee-point, while setting this value to 0% would effectively start exposure at this knee-point.

5.8.6 MultiSlopeIntensityLimit

Name	MultiSlopeIntensityLimit[MultiSlopeKneePointSelector]
Category	AcquisitionControl
Level	Optional
Interface	IFloat
Access	Read/(Write)
Unit	%
Visibility	Expert
Values	0..100

The relative intensity which divides intensities influenced by different exposure slopes.

5.8.7 MultiSlopeExposureGradient

Name	MultiSlopeExposureGradient[MultiSlopeKneePointSelector]
Category	AcquisitionControl
Level	Optional
Interface	IFloat
Access	Read/(Write)
Unit	-
Visibility	Expert
Values	>0

The gradient of the additional slope that is defined by this knee-point.

This gradient is computed by $(\text{MultiSlopeSaturationThreshold}[n+1] - \text{MultiSlopeSaturationTheshold}[n]) / (\text{MultiSlopeExposureLimit}[n+1] - \text{MultiSlopeExposureLimit}[n])$.

In case of a writable MultiSlopeExposureGradient, only MultiSlopeSaturationThreshold and MultiSlopeExposureLimit of the related knee-point should be changed.

6 Analog Control

Features in this chapter describes how to influence the analog features of an image, such as gain, black level, white clip and gamma.

The **Gain**, **BlackLevel** and **Gamma** features will transform the original pixel value Y to a new value Y' according to the following formula:

$$Y' = [(Y + BlackLevel) \cdot Gain]^{Gamma}$$

For some color cameras in Raw or RGB mode, the red/blue channel can be white balanced with respect to the green channel using the Red and blue **BalanceRatio** gain. For cameras in YUV mode the U/V channel can be balanced with respect to the Y channel using the U and V **BalanceRatio**, according to:

$$B' = B(BlueBalanceRatio \cdot Gain)$$

Other color camera controls each color channel gain independently, in which case, the Red, Green and Blue **Gain** features can be used for white balancing.

The automatic functions **GainAuto**, **BlackLevelAuto**, **BalanceWhiteAuto**, **GainAutoTapBalance** and **BlackLevelAutoTapBalance** can be used to auto-adjust a device once or continuously and to turn the function on and off.

Most of the automatic functions have 3 possible values: {**Off**, **Once**, **Continuous**}.

- **Off**: The automatic adjustment is disabled (ie. User control).
- **Once**: The automatic adjustment is performed once by the device. The affected features report the effective values. If necessary, the feature is automatically set to "Off" after the adjustment.
- **Continuous**: The automatic adjustment is continuously done by the device. The affected features report their effective values.

When a device has a specific auto-adjustment capability, it should have a corresponding feature allowing the necessary enumerations.

6.1 AnalogControl

Name	AnalogControl
Category	Root
Level	Optional
Interface	ICategory
Access	Read
Unit	-
Visibility	Beginner
Values	-

Category that contains the Analog control features.

6.2 GainSelector

Name	GainSelector
Category	AnalogControl
Level	Optional
Interface	IEnumeration
Access	Read/Write
Unit	-
Visibility	Beginner
Values	All Red Green Blue Y U V Tap1, Tap2, ... AnalogAll AnalogRed AnalogGreen AnalogBlue AnalogY AnalogU AnalogV AnalogTap1, AnalogTap2, ... DigitalAll

	DigitalRed DigitalGreen DigitalBlue DigitalY DigitalU DigitalV DigitalTap1, DigitalTap2, ...
--	--

Selects which Gain is controlled by the various Gain features.

In general, there are 2 types of gain that can exist in a camera, analog or digital. Some camera will implement one or other or both. This is why there are 3 possible sets of gain.

The first one, without the **Analog** or **Digital** prefix, is to be used when only one type of gain is implemented. This permits to have an implementation independent way to set the gain.

The second and the third, with the **Analog** and **Digital** prefix, is to be used when both types of gain are implemented. This permits to have independent control over each one.

The All gain are intended to be a pre or post stage amplification across all channels or taps, rather than a convenient way to set all the channels or tap gains in a single step.

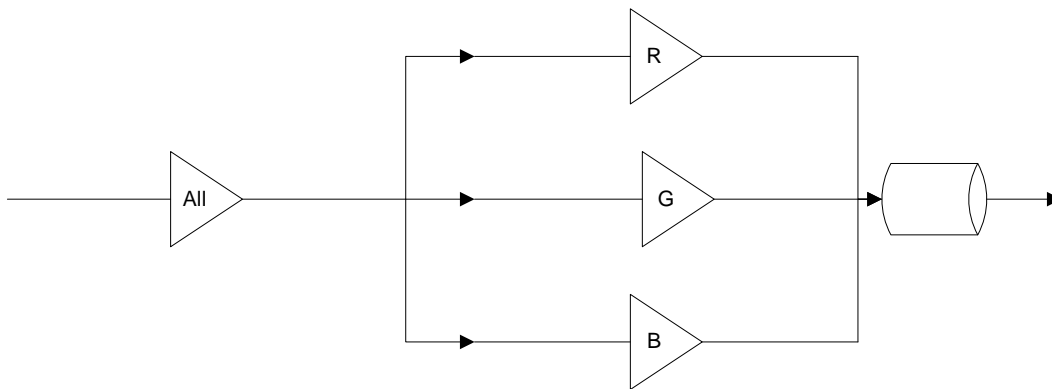

Figure 6-1: Gain All pre amplification

or

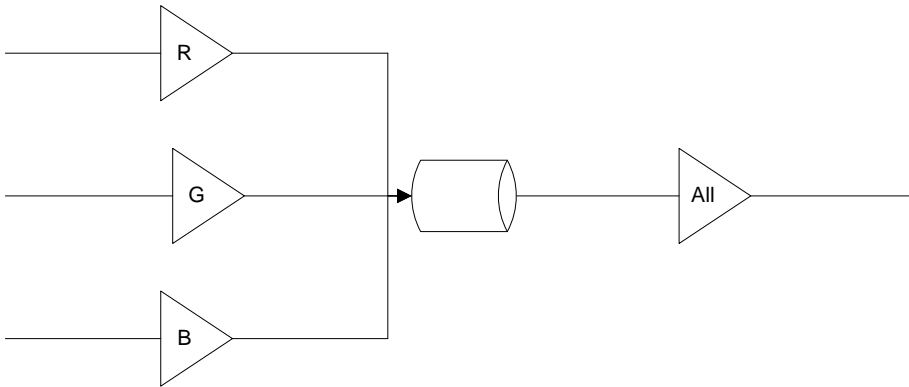

Figure 6-2: Gain All post amplification

By following this rule, the value read for the All gains remains valid even when the channel/tap gains are not all equal.

Possible values are:

- **All:** Gain will be applied to all channels or taps.
- **Red:** Gain will be applied to the red channel.
- **Green:** Gain will be applied to the green channel.
- **Blue:** Gain will be applied to the blue channel.
- **Y:** Gain will be applied to Y channel.
- **U:** Gain will be applied to U channel.
- **V:** Gain will be applied to V channel.
- **Tap1:** Gain will be applied to Tap 1.
- **Tap2:** Gain will be applied to Tap 2.
- ...
- **AnalogAll:** Gain will be applied to all analog channels or taps.
- **AnalogRed:** Gain will be applied to the red analog channel.
- **AnalogGreen:** Gain will be applied to the green analog channel.
- **AnalogBlue:** Gain will be applied to the blue analog channel.
- **AnalogY:** Gain will be applied to Y analog channel.
- **AnalogU:** Gain will be applied to U analog channel.
- **AnalogV:** Gain will be applied to V analog channel.
- **AnalogTap1:** Analog gain will be applied to Tap 1.
- **AnalogTap2:** Analog gain will be applied to Tap 2.

- ...
- **DigitalAll**: Gain will be applied to all digital channels or taps.
- **DigitalRed**: Gain will be applied to the red digital channel.
- **DigitalGreen**: Gain will be applied to the green digital channel.
- **DigitalBlue**: Gain will be applied to the blue digital channel.
- **DigitalY**: Gain will be applied to Y digital channel.
- **DigitalU**: Gain will be applied to U digital channel.
- **DigitalV**: Gain will be applied to V digital channel.
- **DigitalTap1**: Digital gain will be applied to Tap 1.
- **DigitalTap2**: Digital gain will be applied to Tap 2.
- ...

6.3 Gain

Name	Gain[GainSelector]
Category	AnalogControl
Level	Optional
Interface	IFloat
Access	Read/Write
Unit	-
Visibility	Beginner
Values	Device-specific

Controls the selected gain as an absolute physical value. This is an amplification factor applied to the video signal.

The unit and values of this feature are specific to the device and must be defined in the GenICam XML device description file.

For color or multi-tap cameras, **GainSelector** indicates the color channel or tap to control.

6.4 GainAuto

Name	GainAuto[GainSelector]
Category	AnalogControl
Level	Optional

Interface	IEnumeration
Access	Read/Write
Unit	-
Visibility	Beginner
Values	Off Once Continuous Device-specific

Sets the automatic gain control (AGC) mode. The exact algorithm used to implement AGC is device-specific. Some other device-specific features might be used to allow the selection of the algorithm.

Possible values are:

- **Off:** Gain is User controlled using **Gain**.
- **Once:** Gain is automatically adjusted once by the device. Once it has converged, it automatically returns to the **Off** state.
- **Continuous:** Gain is constantly adjusted by the device.

On top of the previous standard values, a device might also provide device-specific values.

6.5 GainAutoBalance

Name	GainAutoBalance
Category	AnalogControl
Level	Optional
Interface	IEnumeration
Access	Read/Write
Unit	-
Visibility	Beginner
Values	Off Once Continuous Device-specific

Sets the mode for automatic gain balancing between the sensor color channels or taps. The gain coefficients of each channel or tap are adjusted so they are matched.

Possible values are:

- **Off:** Gain tap balancing is user controlled using **Gain** .
- **Once:** Gain tap balancing is automatically adjusted once by the device. Once it has converged, it automatically returns to the **Off** state.
- **Continuous:** Gain tap balancing is constantly adjusted by the device.

On top of the previous standard values, a device might also provide device-specific values.

6.6 BlackLevelSelector

Name	BlackLevelSelector
Category	AnalogControl
Level	Optional
Interface	IEnumeration
Access	Read/Write
Unit	-
Visibility	Expert
Values	All Red Green Blue Y U V Tap1, Tap2, ...

Selects which Black Level is controlled by the various Black Level features.

The All Black Level selection is intended to be across all channels or taps, rather than a convenient way to set all the individual channels or taps black levels in a single step. By following this rule, the value read for the All black level remains valid even when the channel/tap black levels are not all equal.

Possible values are:

- **All:** Black Level will be applied to all channels or taps.
- **Red:** Black Level will be applied to the red channel.
- **Green:** Black Level will be applied to the green channel.
- **Blue:** Black Level will be applied to the blue channel.
- **Y:** Black Level will be applied to Y channel.
- **U:** Black Level will be applied to U channel.

- **V**: Black Level will be applied to V channel.
- **Tap1**: Black Level will be applied to Tap 1.
- **Tap2**: Black Level will be applied to Tap 2.
- ...

6.7 BlackLevel

Name	BlackLevel[BlackLevelSelector]
Category	AnalogControl
Level	Optional
Interface	IFloat
Access	Read/Write
Unit	-
Visibility	Expert
Values	Device-specific

Controls the analog black level as an absolute physical value. This represents a DC offset applied to the video signal.

The unit and values of this feature are specific to the device and must be defined in the GenICam XML device description file.

For color or multi-tap cameras, **BlackLevelSelector** indicates which channel access.

6.8 BlackLevelAuto

Name	BlackLevelAuto[BlackLevelSelector]
Category	AnalogControl
Level	Optional
Interface	IEnumeration
Access	Read/Write
Unit	-
Visibility	Expert
Values	Off Once Continuous Device-specific

Controls the mode for automatic black level adjustment. The exact algorithm used to implement this adjustment is device-specific.

Some other device-specific features might be used to allow the selection of the algorithm.

Possible values are:

- **Off:** Analog black level is user controlled using **BlackLevel**.
- **Once:** Analog black level is automatically adjusted once by the device. Once it has converged, it automatically returns to the **Off** state.
- **Continuous:** Analog black level is constantly adjusted by the device.

On top of the previous standard values, a device might also provide device-specific values.

6.9 BlackLevelAutoBalance

Name	BlackLevelAutoBalance
Category	AnalogControl
Level	Optional
Interface	IEnumeration
Access	Read/Write
Unit	-
Visibility	Expert
Values	Off Once Continuous Device-specific

Controls the mode for automatic black level balancing between the sensor color channels or taps. The black level coefficients of each channel are adjusted so they are matched.

Possible values are:

- **Off:** Black level tap balancing is user controlled using **BlackLevel**.
- **Once:** Black level tap balancing is automatically adjusted once by the device. Once it has converged, it automatically returns to the **Off** state.
- **Continuous:** Black level tap balancing is constantly adjusted by the device.

On top of the previous standard values, a device might also provide device-specific values.

6.10 WhiteClipSelector

Name	WhiteClipSelector
Category	AnalogControl
Level	Optional
Interface	IEnumeration
Access	Read/Write
Unit	-
Visibility	Expert
Values	All Red Green Blue Y U V Tap1, Tap2, ...

Selects which White Clip to control.

The **All** White Clip selection is intended to be across all channels or taps, rather than a convenient way to set all the individual channels or tap white clip in a single step. By following this rule, the value read for the All white clip remains valid even when the channel/tap white clips are not all equal.

Possible values are:

- **All:** White Clip will be applied to all channels or taps.
- **Red:** White Clip will be applied to the red channel.
- **Green:** White Clip will be applied to the green channel.
- **Blue:** White Clip will be applied to the blue channel.
- **Y:** White Clip will be applied to Y channel.
- **U:** White Clip will be applied to U channel.
- **V:** White Clip will be applied to V channel.
- **Tap1:** White Clip will be applied to Tap 1.
- **Tap2:** White Clip will be applied to Tap 2.
- ...

6.11 WhiteClip

Name	WhiteClip[WhiteClipSelector]
Category	AnalogControl
Level	Optional
Interface	IFloat
Access	Read/Write
Unit	-
Visibility	Expert
Values	Device-specific

Controls the maximal intensity taken by the video signal before being clipped as an absolute physical value. The video signal will never exceed the white clipping point: it will saturate at that level.

The unit and values of this feature are specific to the device and must be defined in the GenICam XML device description file.

For color or multi-tap cameras, **WhiteClipTapSelector** indicates the channel to control.

6.12 BalanceRatioSelector

Name	BalanceRatioSelector
Category	AnalogControl
Level	Optional
Interface	IEnumeration
Access	Read/Write
Unit	-
Visibility	Expert
Values	All Red Green Blue Y U V Tap1, Tap2, ...

Selects which Balance ratio to control.

Possible values are:

- **All:** Balance Ratio will be applied to all channels or taps.
- **Red:** Balance Ratio will be applied to the red channel.
- **Green:** Balance Ratio will be applied to the green channel.
- **Blue:** Balance Ratio will be applied to the blue channel.
- **Y:** Balance Ratio will be applied to Y channel.
- **U:** Balance Ratio will be applied to U channel.
- **V:** Balance Ratio will be applied to V channel.
- **Tap1:** Balance Ratio will be applied to Tap 1.
- **Tap2:** Balance Ratio will be applied to Tap 2.
- ...

6.13 BalanceRatio

Name	BalanceRatio[BalanceRatioSelector]
Category	AnalogControl
Level	Optional
Interface	IFloat
Access	Read/Write
Unit	-
Visibility	Expert
Values	>0.0

Controls ratio of the selected color component to a reference color component. It is used for white balancing. For example, the Color balance is realized by the following formula:

$$C_w = \text{BalanceRatio} \times C$$

where

C_w is the intensity of selected color component after white balancing.

BalanceRatio is the white balance coefficient.

C is the intensity of the color component before white balancing.

6.14 BalanceWhiteAuto

Name	BalanceWhiteAuto
-------------	------------------

Category	AnalogControl
Level	Optional
Interface	IEnumeration
Access	Read/Write
Unit	-
Visibility	Expert
Values	Off Once Continuous Device-specific

Controls the mode for automatic white balancing between the color channels. The white balancing ratios are automatically adjusted.

Possible values are:

- **Off:** White balancing is user controlled using **BalanceRatioSelector** and **BalanceRatio**.
- **Once:** White balancing is automatically adjusted once by the device. Once it has converged, it automatically returns to the **Off** state.
- **Continuous:** White balancing is constantly adjusted by the device.

On top of the previous standard values, a device might also provide device-specific values.

6.15 Gamma

Name	Gamma
Category	AnalogControl
Level	Optional
Interface	IFloat
Access	Read/Write
Unit	-
Visibility	Beginner
Values	>0.0

Controls the gamma correction of pixel intensity. This is typically used to compensate for non-linearity of the display system (such as CRT).

Gamma correction is realized by the following formula:

$$Y' = Y^{\text{Gamma}}$$

where

Y' is the new pixel intensity

Y is the original pixel intensity

Gamma is the correction factor

The realization of the gamma correction can be implemented using a LUT. Therefore, it is possible that some LUT functionality is not available when gamma correction is activated.

7 LUT Control

Features in this chapter describe the Look-up table (LUT) related features.

7.1 LUTControl

Name	LUTControl
Category	Root
Level	Optional
Interface	ICategory
Access	Read
Unit	-
Visibility	Expert
Values	-

Category that includes the LUT control features.

7.2 LUTSelector

Name	LUTSelector
Category	LUTControl
Level	Optional
Interface	IEnumeration
Access	Read/Write
Unit	-
Visibility	Expert
Values	Luminance Red Green Blue Device-specific

Selects which LUT to control.

Possible values are:

- **Luminance:** Selects the Luminance LUT.
- **Red:** Selects the Red LUT.

- **Green:** Selects the Green LUT.
- **Blue:** Selects the Blue LUT.

This feature is typically not available when only a single LUT is supported.

7.3 LUTEnable

Name	LUTEnable[LUTSelector]
Category	LUTControl
Level	Optional
Interface	IBoolean
Access	Read/Write
Unit	-
Visibility	Expert
Values	True False

Activates the selected LUT.

7.4 LUTIndex

Name	LUTIndex[LUTSelector]
Category	LUTControl
Level	Optional
Interface	IInteger
Access	Read/Write
Unit	-
Visibility	Guru
Values	≥ 0

Control the index (offset) of the coefficient to access in the selected LUT.

7.5 LUTValue

Name	LUTValue[LUTSelector][LUTIndex]
Category	LUTControl
Level	Optional

Interface	Integer
Access	Read/Write
Unit	-
Visibility	Guru
Values	Device-specific

Returns the Value at entry **LUTIndex** of the LUT selected by **LUTSelector**.

7.6 LUTValueAll

Name	LUTValueAll[LUTSelector]
Category	LUTControl
Level	Optional
Interface	IRegister
Access	Read/Write
Unit	-
Visibility	Guru
Values	Device-specific

Accesses all the LUT coefficients in a single access without using individual **LUTIndex**.

8 Color Transformation Control

The Color Transformation chapter describes all features related to color Transformations in the device.

The Color Transformation is a linear operation taking as input a triplet of Components (C0, C1, C2) for a color pixel (Typicaly: R_{in}, G_{in}, B_{in} representing a RGB color pixel). This triplet is first multiplied by a 3x3 matrix and then added to an offset triplet.

The equation is given by:

$$\begin{pmatrix} R_{out} \\ G_{out} \\ B_{out} \end{pmatrix} = \begin{pmatrix} Gain00 & Gain01 & Gain02 \\ Gain10 & Gain11 & Gain12 \\ Gain20 & Gain21 & Gain22 \end{pmatrix} \begin{pmatrix} C0_{in} \\ C1_{in} \\ C2_{in} \end{pmatrix} + \begin{pmatrix} Offset0 \\ Offset1 \\ Offset2 \end{pmatrix}$$

$$\text{Equivalent: } \begin{pmatrix} R_{out} \\ G_{out} \\ B_{out} \end{pmatrix} = \begin{pmatrix} RR & RG & RB \\ GR & GG & GB \\ BR & BG & BB \end{pmatrix} \begin{pmatrix} R_{in} \\ G_{in} \\ B_{in} \end{pmatrix} + \begin{pmatrix} R_{offset} \\ G_{offset} \\ B_{offset} \end{pmatrix}$$

The descriptions below assume RGB to RGB transformation:

Where	C0 _{in} is the first component of the incoming pixel
	C1 _{in} is the second component of the incoming pixel
	C2 _{in} is the third component of the incoming pixel
	Gain00 is the red contribution to the red pixel (multiplicative factor)
	Gain01 is the green contribution to the red pixel (multiplicative factor)
	Gain02 is the blue contribution to the red pixel (multiplicative factor)
	Gain10 is the red contribution to the green pixel (multiplicative factor)
	Gain11 is the green contribution to the green pixel (multiplicative factor)
	Gain12 is the blue contribution to the blue pixel (multiplicative factor)
	Gain20 is the red contribution to the blue pixel (multiplicative factor)
	Gain21 is the green contribution to the blue pixel (multiplicative factor)
	Gain22 is the blue contribution to the blue pixel (multiplicative factor)
	Offset0 is the red offset
	Offset1 is the green offset

	Offset2 is the blue offset
	C0 _{out} is the first resulting component of the pixel after the transformation
	C1 _{out} is the second resulting component of the pixel after the transformation
	C2 _{out} is the third resulting component of the pixel after the transformation

Example for YUV conversion:

The Color Transformation can also be used outside of the simple scope of color correction on RGB pixels. For instance, it can be used as a color convert to convert RGB to YUV.

Here is the example of this conversion for 8-bit pixels:

$$\begin{pmatrix} Y \\ U \\ V \end{pmatrix} = \begin{pmatrix} 0.299 & 0.587 & 0.114 \\ -0.147 & -0.289 & 0.436 \\ 0.615 & -0.515 & -0.100 \end{pmatrix} \begin{pmatrix} R_{in} \\ G_{in} \\ B_{in} \end{pmatrix} + \begin{pmatrix} 0 \\ 128 \\ 128 \end{pmatrix}$$

8.1 ColorTransformationControl

Name	ColorTransformationControl
Category	Root
Level	Recommended
Interface	ICategory
Access	Read
Unit	-
Visibility	Expert
Values	-

Category that contains the Color Transformation control features.

8.2 ColorTransformationSelector

Name	ColorTransformationSelector
Category	ColorTransformationControl
Level	Optional
Interface	IEnumeration
Access	Read/Write
Unit	-

Visibility	Expert
Values	RGBtoRGB RGBtoYUV Device-specific

Selects which Color Transformation module is controlled by the various Color Transformation features.

Possible values are:

- **RGBtoRGB:** RGB to RGB color transformation.
- **RGBtoYUV:** RGB to YUV color transformation.

It is typically not available when a single Color Transformation module is supported.

8.3 ColorTransformationEnable

Name	ColorTransformationEnable[ColorTransformationSelector]
Category	ColorTransformationControl
Level	Optional
Interface	IBoolean
Access	Read/Write
Unit	-
Visibility	Expert
Values	True False

Activates the selected Color Transformation module.

8.4 ColorTransformationValueSelector

Name	ColorTransformationValueSelector[ColorTransformationSelector]
Category	ColorTransformationControl
Level	Optional
Interface	IEnumeration
Access	Read/Write
Unit	-
Visibility	Expert
Values	Gain00

	Gain01
	Gain02
	Gain10
	Gain11
	Gain12
	Gain20
	Gain21
	Gain22
	Offset0
	Offset1
	Offset2

Selects the Gain factor or Offset of the Transformation matrix to access in the selected Color Transformation module.

Possible values are:

- **Gain00:** Gain 0,0 of the transformation matrix.
- **Gain01:** Gain 0,1 of the transformation matrix.
- **Gain02:** Gain 0,2 of the transformation matrix.
- **Gain10:** Gain 1,0 of the transformation matrix.
- **Gain11:** Gain 1,1 of the transformation matrix.
- **Gain12:** Gain 1,2 of the transformation matrix.
- **Gain20:** Gain 2,0 of the transformation matrix.
- **Gain21:** Gain 2,1 of the transformation matrix.
- **Gain22:** Gain 2,2 of the transformation matrix.
- **Offset0:** Offset 0 of the transformation matrix.
- **Offset1:** Offset 1 of the transformation matrix.
- **Offset2:** Offset 2 of the transformation matrix.

8.5 ColorTransformationValue

Name	ColorTransformationValue[ColorTransformationSelector] [ColorTransformationValueSelector]
Category	ColorTransformationControl
Level	Optional
Interface	IFloat

Access	Read/Write
Unit	-
Visibility	Expert
Values	Device-Specific

Represents the value of the selected Gain factor or Offset inside the Transformation matrix.

9 Digital I/O Control

The Digital I/O chapter covers the features required to control the general Input and Output signals of the device. This includes input and output control signals for Triggers Timers, counters and also static signals such as user configurable input or output bits.

9.1 Digital I/O usage model

The Digital I/O Control model presents each I/O **Line** as a physical line of a device connector and that goes into or comes from an **I/O Control Block** permitting to condition and to monitor the incoming or outgoing signal.

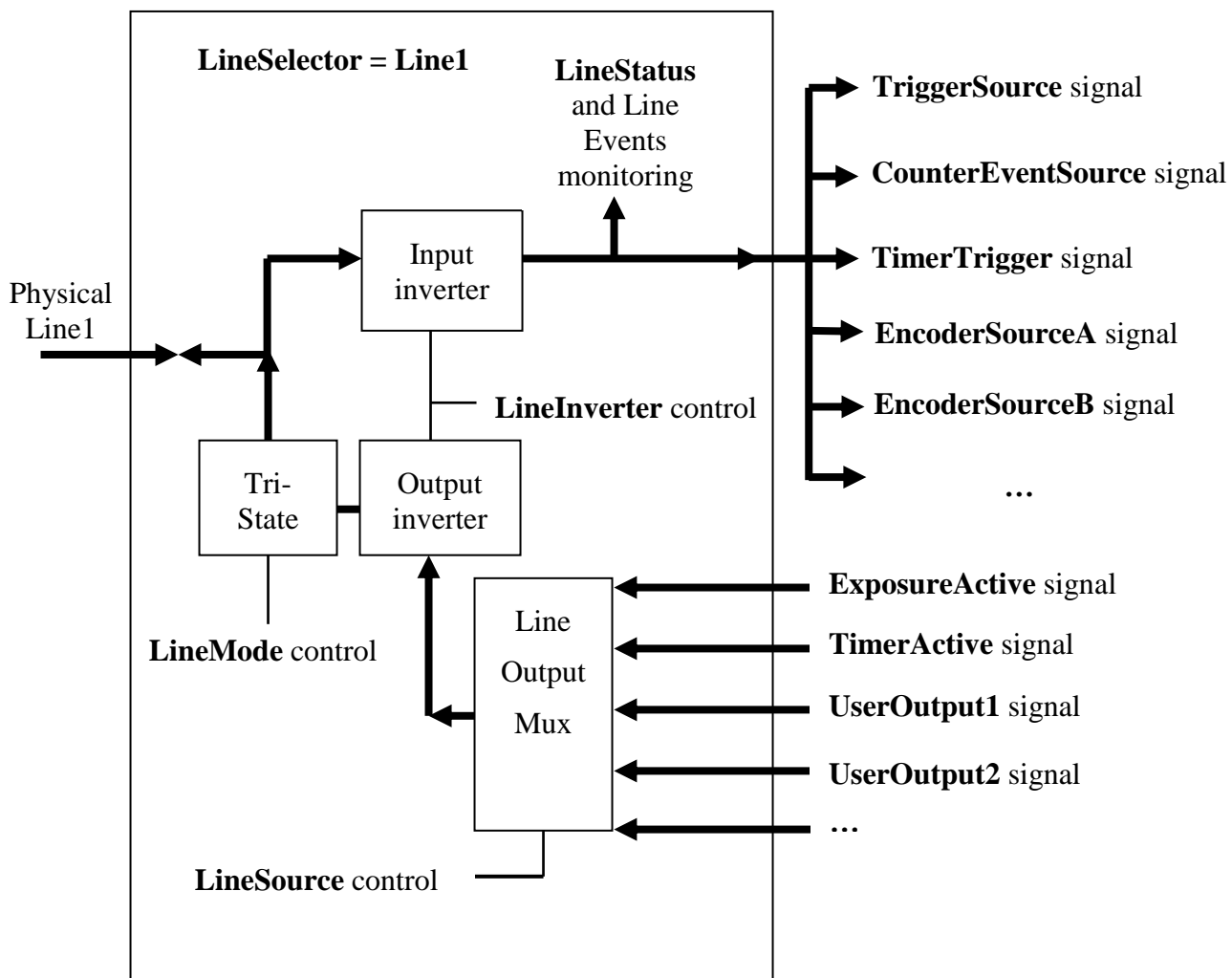

Figure 9-1: I/O Control

I/O Lines:

For a Digital I/O, when the full **I/O Control Block** is implemented, each physical **Line** (or pin) selected using **LineSelector** can be configured as Input or Output using **LineMode**. For an input or output Line, it is possible to read the Status of the Line with **LineStatus** and the incoming or outgoing signal can also be inverted using **LineInverter**. For an Output signal, the source of the signal is controlled using **LineSource** (See Figure 9-1).

For example:

```
/* Output an inverted pulse coming from the Timer 1 on the physical Line 2 of
the device connector.
```

```
*/
```

```
LineSelector = Line2;
LineMode     = Output;
LineInverter = True;
LineSource   = Timer1Active;
```

```
/* Read the inverted Status of the physical Line 1. */
```

```
LineSelector = Line1;
LineMode     = Input;
LineInverter = True;
CurrentStatus = LineStatus;
```

```
/* Output of the Exposure signal of each frame on the physical Line 2. */
```

```
LineSelector = Line2;
LineMode     = Output;
LineSource   = ExposureActive;
```

Note that all the features of an I/O control block are optional. Typically, an Input only line will report the **LineMode** as **Input** (read-only) and will implement only the **LineSelector**, **LineInverter** and **LineStatus** features (top half in Figure 9-1: I/O Control). An Output only line will report the **LineMode** as **Output** (read-only) and will implement only the **LineSelector**, **LineInverter** and **LineSource** features (bottom half of Figure 9-1: I/O Control). Even a hard-wired input or output line is just particular case where all the features are read-only.

The electrical format of the physical Line (TTL, LVDS, Opto-Coupled...) can be read or controlled (if supported) using **LineFormat**.

Note also that the Status of all the Lines can be monitored in one single access using **LineStatusAll**.

UserOutput:

One possible source for Output lines is the User Output bit register.

Using **LineSource**, each of the bits of the User Output register can be directed to a physical output Line after going through the I/O control block (See Figure 9-1: I/O Control).

UserOutputSelector and **UserOutputValue** are used to set any individual bit of the User Output register. **UserOutputValueAll** and **UserOutputValueAllMask** can be used to set all or many of the User Output bits in one access.

Example:

/* User Output of a positive TTL signal on physical Line 2. */

```

LineSelector      = Line2;
LineMode          = Output;
LineFormat        = TTL;
LineSource        = UserOutput2;

UserOutputSelector = UserOutput2;
UserOutputValue   = True;
    
```

9.2 Digital I/O Control features

This section lists the digital I/O control features.

9.2.1 DigitalIOControl

Name	DigitalIOControl
Category	Root
Level	Recommended
Interface	ICategory
Access	Read
Unit	-
Visibility	Expert
Values	-

Category that contains the digital input and output control features.

9.2.2 LineSelector

Name	LineSelector
Category	DigitalIOControl
Level	Recommended

Interface	IEnumeration
Access	Read/Write
Unit	-
Visibility	Expert
Values	Line0 (If 0 based), Line1, Line2, ... LinkTrigger0 (If 0 based), LinkTrigger1, LinkTrigger2, ... CC1, CC2, CC3, CC4, ...

Selects the physical line (or pin) of the external device connector or the virtual line of the Transport Layer to configure.

When a Line is selected, all the other Line features will be applied to its associated I/O control block and will condition the resulting input or output signal.

Possible values are:

- **Line0** (If 0 based), **Line1**, **Line2**, ...: Index of the physical line and associated I/O control block to use.
- **LinkTrigger0** (If 0 based), **LinkTrigger1**, **LinkTrigger2**, ...: Index of the virtual line going on the Transport layer to use.
- **CC1**, **CC2**, **CC3**, **CC4**: Index of the Camera Link physical line and associated I/O control block to use. This ensures a **direct** mapping between the lines on the frame grabber and on the camera. Applicable to CameraLink Product only.

9.2.3 LineMode

Name	LineMode[LineSelector]
Category	DigitalIOControl
Level	Optional
Interface	IEnumeration
Access	Read/Write
Unit	-
Visibility	Expert
Values	Input Output

Controls if the physical Line is used to Input or Output a signal.

When a Line supports input and output mode, the default state is Input to avoid possible electrical contention.

Possible values are:

- **Input:** The selected physical line is used to Input an electrical signal.
- **Output:** The selected physical line is used to Output an electrical signal.

9.2.4 LineInverter

Name	LineInverter[LineSelector]
Category	DigitalIOControl
Level	Recommended
Interface	IBoolean
Access	Read/Write
Unit	-
Visibility	Expert
Values	False True

Controls the inversion of the signal of the selected input or output Line.

Possible values are:

- **False:** The Line signal is not inverted.
- **True:** The Line signal is inverted.

9.2.5 LineStatus

Name	LineStatus[LineSelector]
Category	DigitalIOControl
Level	Recommended
Interface	IBoolean
Access	Read
Unit	-
Visibility	Expert
Values	False True

Returns the current status of the selected input or output Line.

The status of the signal is taken after the input Line inverter of the I/O control block.

Possible values are:

- **True:** The level of the Line signal is High.
- **False:** The level of the Line signal is Low.

9.2.6 LineStatusAll

Name	LineStatusAll
Category	DigitalIOControl
Level	Optional
Interface	IInteger
Access	Read
Unit	-
Visibility	Expert
Values	Device-specific

Returns the current status of all available Line signals at time of polling in a single bitfield. The order is Line0 (If 0 based), Line1, Line2,... (lsb to msb).

9.2.7 LineSource

Name	LineSource[LineSelector]
Category	DigitalIOControl
Level	Recommended
Interface	IEnumeration
Access	Read/Write
Unit	-
Visibility	Expert
Values	Off UserOutput0, UserOutput1, UserOutput2, ... AcquisitionTriggerWait AcquisitionTrigger AcquisitionTriggerMissed AcquisitionActive FrameTriggerWait FrameTrigger FrameTriggerMissed FrameActive ExposureActive LineTriggerWait

LineTrigger
 LineTriggerMissed
 LineActive
 Counter0Active, Counter1Active, Counter2Active, ...
 Timer0Active, Timer1Active, Timer2Active, ...
 Encoder0, Encoder1, Encoder2, ...
 LogicBlock0, LogicBlock1, LogicBlock2, ...
 SoftwareSignal0, SoftwareSignal1, SoftwareSignal2, ...
 Stream0TransferActive, Stream1TransferActive, ...
 Stream0TransferPaused, Stream1TransferPaused, ...
 Stream0TransferStopping, Stream1TransferStopping, ...
 Stream0TransferStopped, Stream1TransferStopped, ...
 Stream0TransferOverflow, Stream1TransferOverflow, ...

Selects which internal acquisition or I/O source signal to output on the selected Line. **LineMode** must be **Output**.

See Figure 9-1 for details.

Possible values are:

- **Off**: Line output is disabled (Tri-State).
- **UserOutput0, UserOutput1, UserOutput2, ...**: The chosen User Output Bit state as defined by its current **UserOutputValue**.
- **AcquisitionTriggerWait**: Device is currently waiting for a trigger for the capture of one or many Frames.
- **AcquisitionActive**: Device is currently doing an acquisition of one or many Frames.
- **AcquisitionTriggerWait**: Device is currently waiting for an Acquisition start trigger.
- **AcquisitionTrigger**: Device is receiving an Acquisition start trigger.
- **AcquisitionTriggerMissed**: Device has missed an Acquisition start trigger.
- **FrameTriggerWait**: Device is currently waiting for a Frame start trigger.
- **FrameTrigger**: Device is receiving a Frame start trigger.
- **FrameTriggerMissed**: Device has missed a Frame start trigger.
- **FrameActive**: Device is currently doing the capture of a Frame.
- **LineTriggerWait**: Device is currently waiting for a Line start trigger.
- **LineTrigger**: Device is receiving a Line start trigger.
- **LineTriggerMissed**: Device has missed a Line start trigger.
- **LineActive**: Device is currently doing the capture of a Line.
- **ExposureActive**: Device is doing the exposure of a Frame (or Line).

- **Counter0Active, Counter1Active, Counter2Active, ...:** The chosen counter is in active state (counting).
- **Timer0Active, Timer1Active, Timer2Active, ...:** The chosen Timer is in active state.
- **Encoder0, Encoder1, Encoder2, ...:** The chosen Encoder Output state.
- **LogicBlock0, LogicBlock1, LogicBlock2, ...:** The chosen Logic Block output state.
- **SoftwareSignal0, SoftwareSignal1, SoftwareSignal2, ...:** The chosen Software Signal output state.
- **Stream0TransferActive, Stream1TransferActive, ...:** Transfer on the stream is active.
- **Stream0TransferPaused, Stream1TransferPaused, ...:** Transfer on the stream is paused.
- **Stream0TransferStopping, Stream1TransferStopping, ...:** Transfer on the stream is stopping.
- **Stream0TransferStopped, Stream1TransferStopped, ...:** Transfer on the stream is stopped.
- **Stream0TransferOverflow, Stream1TransferOverflow, ...:** Transfer on the stream is in overflow.

9.2.8 LineFormat

Name	LineFormat[LineSelector]
Category	DigitalIOControl
Level	Optional
Interface	IEnumeration
Access	Read/Write
Unit	-
Visibility	Expert
Values	NoConnect TriState TTL LVDS RS422 OptoCoupled OpenDrain

Controls the current electrical format of the selected physical input or output **Line**.

Possible values are:

- **NoConnect:** The Line is not connected.
- **TriState:** The Line is currently in Tri-State mode (Not driven).
- **TTL:** The Line is currently accepting or sending TTL level signals.
- **LVDS:** The Line is currently accepting or sending LVDS level signals.

- **RS422:** The Line is currently accepting or sending RS422 level signals.
- **OptoCoupled:** The Line is opto-coupled.
- **OpenDrain:** The Line is Open Drain (or Open Collector).

9.2.9 UserOutputSelector

Name	UserOutputSelector
Category	DigitalIOControl
Level	Recommended
Interface	IEnumeration
Access	Read/Write
Unit	-
Visibility	Expert
Values	UserOutput0, UserOutput1, UserOutput2, ...

Selects which bit of the User Output register will be set by **UserOutputValue**.

Possible values are:

- **UserOutput0:** Selects the bit 0 of the User Output register.
- **UserOutput1:** Selects the bit 1 of the User Output register.
- **UserOutput2:** Selects the bit 2 of the User Output register.
- ...

9.2.10 UserOutputValue

Name	UserOutputValue[UserOutputSelector]
Category	DigitalIOControl
Level	Recommended
Interface	IBoolean
Access	Read/Write
Unit	-
Visibility	Expert
Values	True False

Sets the value of the bit selected by UserOutputSelector.

9.2.11 UserOutputValueAll

Name	UserOutputValueAll
Category	DigitalIOControl
Level	Optional
Interface	IInteger
Access	Read/Write
Unit	-
Visibility	Expert
Values	Device-specific

Sets the value of all the bits of the User Output register. It is subject to the **UserOutputValueAllMask**.

UserOutputValueAll can take any binary value and each bit set to one will set the corresponding User Output register bit to high. Note that the UserOutputs are numbered from 0 to N (If 0 based). This means that the least significant bit of **UserOutputValueAll** corresponds to the UserOutput0 (if 0 based).

9.2.12 UserOutputValueAllMask

Name	UserOutputValueAllMask
Category	DigitalIOControl
Level	Optional
Interface	IInteger
Access	Read/Write
Unit	-
Visibility	Expert
Values	Device-specific

Sets the write mask to apply to the value specified by **UserOutputValueAll** before writing it in the User Output register. If the **UserOutputValueAllMask** feature is present, setting the user Output register using **UserOutputValueAll** will only change the bits that have a corresponding bit in the mask set to one.

UserOutputValueAllMask can take any binary value. Each bit set to one will enable writing of the corresponding User Output register bit and each bit set to zero will prevent it.

Note that **UserOutputValueAllMask** is ignored when an individual bit is set using **UserOutputValue**.

10 Counter and Timer Control

This chapter lists all features that relates to control and monitoring of Counters and Timers.

Note that Counters and Timers can also be used to generate an Event when a predetermined maximum count (or duration) is reached. See the **EventSelector** feature.

10.1 Counter and Timer category

This section define the category that includes Counter's and Timer's features.

10.1.1 CounterAndTimerControl

Name	CounterAndTimerControl
Category	Root
Level	Recommended
Interface	ICategory
Access	Read
Unit	-
Visibility	Expert
Values	-

Category that contains the Counter and Timer control features.

10.2 Counter usage model

This section describes the Counters usage model.

A Counter is used to count internal events (FrameStart, Timer1End, ...), I/O external events (Input Line rising edge, ...) and even clock ticks. It can be reset, read or written at anytime. Counters can also be cascaded to increase their range if necessary.

To set the destination output Line of a Counter, see for example **Counter1Active** entry of the **LineSource** feature.

Note that Counters can also be used to generate an Event when a predetermined maximum count (or duration) is reached. See the **EventSelector** feature.

Below we show examples of typical use cases of counter's control features in C/C++ pseudo-code.

For simplicity, the object name is omitted (e.g. **CounterValue** instead of **Camera.CounterValue**) and the default state of the device is assumed.

/* Counts the number of missed triggers during an Acquisition.*/

```
CounterSelector      = Counter1;
CounterTriggerSource = AcquisitionStart;
CounterResetSource  = CounterTrigger;
CounterEventSource   = FrameTriggerMissed;

AcquisitionMode      = Continuous;
AcquisitionStart();
...
AcquisitionStop();
NbPulses              = CounterValue;
printf("%ld Triggers missed during the acquisition.", NbPulses);
```

/* Counts the number of rising edge signals received on Line1 during a frame.*/

```
CounterSelector      = Counter1;
CounterTriggerSource = FrameStart;
CounterResetSource   = CounterTrigger;
CounterEventSource   = Line1;
CounterEventActivation = RisingEdge;

AcquisitionMode      = SingleFrame;
AcquisitionStart();
...
NbPulses              = CounterValue;
printf("%ld Input Pulses received during the frame.", NbPulses);
```

/* Use a counter to generate an event at line 200 of each captured Frame
in a continuous acquisition.
*/

```

CounterSelector      = Counter1;
CounterEventSource  = LineStart;
CounterDuration     = 200;
CounterTriggerSource = FrameStart;
CounterResetSource  = CounterTrigger;

Register (Camera.EventCounter1End, CallbackDataObject, CallbackFunctionPtr)

EventSelector       = Counter1End;
EventNotification   = On;

AcquisitionMode     = Continuous;
AcquisitionStart ();
...
AcquisitionStop ();
    
```

10.3 Counter features

This section describes the Counter features.

10.3.1 CounterSelector

Name	CounterSelector
Category	CounterAndTimerControl
Level	Recommended
Interface	IEnumeration
Access	Read/Write
Unit	-
Visibility	Expert
Values	Counter0 (If 0 based), Counter1, Counter2, ...

Selects which Counter to configure.

Possible values are:

- **Counter0**: Selects the counter 0.
- **Counter1**: Selects the counter 1.
- **Counter2**: Selects the counter 2.

- ...

10.3.2 CounterEventSource

Name	CounterEventSource[CounterSelector]
Category	CounterAndTimerControl
Level	Recommended
Interface	IEnumeration
Access	Read/Write
Unit	-
Visibility	Expert
Values	Off AcquisitionTrigger AcquisitionTriggerMissed AcquisitionStart AcquisitionEnd FrameTrigger FrameTriggerMissed FrameStart FrameEnd FrameBurstStart FrameBurstEnd LineTrigger LineTriggerMissed LineStart LineEnd ExposureStart ExposureEnd Line0 (If 0 based), Line1, Line2, ... Counter0Start (If 0 based), Counter1Start, Counter2Start, ... Counter0End (If 0 based), Counter1End, Counter2End, ... Timer0Start (If 0 based), Timer1Start, Timer2Start, ... Timer0End (If 0 based), Timer1End, Timer2End, ... Encoder0(if 0 based), Encoder1, Encoder2, ... LogicBlock0 (If 0 based), LogicBlock1, LogicBlock2, ... SoftwareSignal0 (If 0 based), SoftwareSignal1, SoftwareSignal2, ... Action0 (If 0 based), Action1, Action2, ... LinkTrigger0 (If 0 based), LinkTrigger1, LinkTrigger2, ... TimestampTick

Select the events that will be the source to increment the Counter.

See Figure 5-1, Figure 5-3 and Figure 5-4 for details.

Possible values are:

- **Off**: Counter is stopped.
- **AcquisitionTrigger**: Counts the number of Acquisition Trigger.
- **AcquisitionTriggerMissed**: Counts the number of missed Acquisition Start Trigger.
- **AcquisitionStart**: Counts the number of Acquisition Start.
- **AcquisitionEnd**: Counts the number of Acquisition End.
- **FrameTrigger**: Counts the number of Frame Start Trigger.
- **FrameTriggerMissed**: Counts the number of missed Frame Start Trigger.
- **FrameStart**: Counts the number of Frame Start.
- **FrameEnd**: Counts the number of Frame End.
- **FrameBurstStart**: Counts the number of Frame Burst Start.
- **FrameBurstEnd**: Counts the number of Frame Burst End.
- **LineTrigger**: Counts the number of Line Start Trigger.
- **LineTriggerMissed**: Counts the number of missed Line Start Trigger.
- **LineStart**: Counts the number of Line Start.
- **LineEnd**: Counts the number of Line End.
- **ExposureStart**: Counts the number of Exposure Start.
- **ExposureEnd**: Counts the number of Exposure End.
- **Line0, Line1, Line2, ...**: Counts the number of transitions on the chosen I/O Line.
- **Counter0Start, Counter1Start, Counter2Start, ...**: Counts the number of Counter Start.
- **Counter0End, Counter1End, Counter2End, ...**: Counts the number of Counter End.
- **Timer0Start, Timer1Start, Timer2Start, ...**: Counts the number of Timer Start pulses generated.
- **Timer0End, Timer1End, Timer2End, ...**: Counts the number of Timer End pulses generated.
- **Encoder0, Encoder1, Encoder2, ...**: Counts the number of Encoder output pulses.
- **LogicBlock0, LogicBlock1, LogicBlock2, ...**: Counts the number of Logic Block output pulses.
- **SoftwareSignal0, SoftwareSignal1, SoftwareSignal2, ...**: Counts the number of Software Signal.
- **Action0, Action1, Action2, ...**: Counts the number of assertions of the chosen action signal.
- **LinkTrigger0, LinkTrigger1, LinkTrigger2, ...**: Counts the number of Link Trigger.
- **TimestampTick**: Counts the number of clock ticks of the Timestamp clock. Can be used to create a programmable timer.

10.3.3 CounterEventActivation

Name	CounterEventActivation[CounterSelector]
Category	CounterAndTimerControl
Level	Recommended
Interface	IEnumeration
Access	Read/Write
Unit	-
Visibility	Expert
Values	RisingEdge FallingEdge AnyEdge

Selects the Activation mode Event Source signal.

Possible values are:

- **RisingEdge**: Counts on the Rising Edge of the signal.
- **FallingEdge**: Counts on the Falling Edge of the signal.
- **AnyEdge**: Counts on the Falling or rising Edge of the selected signal.

10.3.4 CounterResetSource

Name	CounterResetSource[CounterSelector]
Category	CounterAndTimerControl
Level	Recommended
Interface	IEnumeration
Access	Read/Write
Unit	-
Visibility	Expert
Values	Off CounterTrigger AcquisitionTrigger AcquisitionTriggerMissed AcquisitionStart AcquisitionEnd FrameTrigger

FrameTriggerMissed
 FrameStart
 FrameEnd
 LineTrigger
 LineTriggerMissed
 LineStart
 LineEnd
 ExposureStart
 ExposureEnd
 Line0 (If 0 based), Line1, Line2, ...
 UserOutput0, UserOutput1,
 UserOutput2,...
 Counter0Start (If 0 based),
 Counter1Start, Counter2Start, ...
 Counter0End (If 0 based),
 Counter1End, Counter2End, ...
 Timer0Start (If 0 based), Timer1Start,
 Timer2Start, ...
 Timer0End (If 0 based), Timer1End,
 Timer2End, ...
 Encoder0 (if 0 based), Encoder1,
 Encoder2, ...
 LogicBlock0 (If 0 based),
 LogicBlock1, LogicBlock2, ...
 SoftwareSignal0 (If 0 based),
 SoftwareSignal1, SoftwareSignal2, ...
 Action0 (If 0 based), Action1,
 Action2, ...
 LinkTrigger0 (If 0 based),
 LinkTrigger1, LinkTrigger2, ...

Selects the signals that will be the source to reset the Counter.

Possible values are:

- **Off**: Disable the Counter Reset trigger.
- **CounterTrigger**: Resets with the reception of a trigger on the **CounterTriggerSource**.
- **AcquisitionTrigger**: Resets with the reception of the Acquisition Trigger.
- **AcquisitionTriggerMissed**: Resets with the reception of the missed Acquisition start trigger.
- **AcquisitionStart**: Resets with the reception of the Acquisition Start.
- **AcquisitionEnd**: Resets with the reception of the Acquisition End.
- **FrameTrigger**: Resets with the reception of the Frame Start Trigger.

- **FrameTriggerMissed**: Resets with the reception of the missed Frame start trigger.
- **FrameStart**: Resets with the reception of the Frame Start.
- **FrameEnd**: Resets with the reception of the Frame End.
- **FrameBurstStart**: Resets with the reception of the Frame Burst Start.
- **FrameBurstEnd**: Resets with the reception of the Frame Burst End.
- **LineTrigger**: Resets with the reception of the Line Start Trigger.
- **LineTriggerMissed**: Resets with the reception of the missed Line start trigger.
- **LineStart**: Resets with the reception of the Line Start.
- **LineEnd**: Resets with the reception of the Line End.
- **ExposureStart**: Resets with the reception of the Exposure Start.
- **ExposureEnd**: Resets with the reception of the Exposure End.
- **Line0** (If 0 based), **Line1**, **Line2**, ...: Resets by the chosen I/O Line.
- **UserOutput0**, **UserOutput1**, **UserOutput2**, ...: Resets by the chosen User Output bit.
- **Counter0Start**, **Counter1Start**, **Counter2Start**, ...: Resets with the reception of the Counter Start.
- **Counter0End**, **Counter1End**, **Counter2End**, ...: Resets with the reception of the Counter End.
- **Timer0Start**, **Timer1Start**, **Timer2Start**, ...: Resets with the reception of the Timer Start.
- **Timer0End**, **Timer1End**, **Timer2End**, ...: Resets with the reception of the Timer End.
- **Encoder0**, **Encoder1**, **Encoder2**, ...: Resets with the reception of the Encoder output signal.
- **LogicBlock0**, **LogicBlock1**, **LogicBlock2**, ...: Resets with the reception of the LogicBlock output signal.
- **SoftwareSignal0**, **SoftwareSignal1**, **SoftwareSignal2**, ...: Resets on the reception of the Software Signal.
- **Action0**, **Action1**, **Action2**, ...: Resets on assertions of the chosen action signal (Broadcasted signal on the transport layer).
- **LinkTrigger0**, **LinkTrigger1**, **LinkTrigger2**, ...: Resets on the reception of the chosen Link Trigger (received from the transport layer).

Note that the value of the Counter at time of reset is automatically latched and reflected in **CounterValueAtReset**.

10.3.5 CounterResetActivation

Name	CounterResetActivation[CounterSelector]
Category	CounterAndTimerControl
Level	Recommended

Interface	IEnumeration
Access	Read/Write
Unit	-
Visibility	Expert
Values	RisingEdge FallingEdge AnyEdge LevelHigh LevelLow

Selects the Activation mode of the Counter Reset Source signal.

Possible values are:

- **RisingEdge**: Resets the counter on the Rising Edge of the signal.
- **FallingEdge**: Resets the counter on the Falling Edge of the signal.
- **AnyEdge**: Resets the counter on the Falling or rising Edge of the selected signal.
- **LevelHigh**: Resets the counter as long as the selected signal level is High.
- **LevelLow**: Resets the counter as long as the selected signal level is Low.

10.3.6 CounterReset

Name	CounterReset[CounterSelector]
Category	CounterAndTimerControl
Level	Recommended
Interface	ICommand
Access	(Read)/Write
Unit	-
Visibility	Expert
Values	-

Does a software reset of the selected Counter and starts it. The counter starts counting events immediately after the reset unless a Counter trigger is active. CounterReset can be used to reset the Counter independently from the CounterResetSource. To disable the counter temporarily, set **CounterEventSource** to **Off**.

Note that the value of the Counter at time of reset is automatically latched and reflected in the **CounterValueAtReset**.

10.3.7 CounterValue

Name	CounterValue[CounterSelector]
Category	CounterAndTimerControl
Level	Recommended
Interface	IInteger
Access	Read/Write
Unit	-
Visibility	Expert
Values	≥ 0

Reads or writes the current value of the selected Counter.

Writing to CounterValue is typically used to set the start value.

10.3.8 CounterValueAtReset

Name	CounterValueAtReset[CounterSelector]
Category	CounterAndTimerControl
Level	Recommended
Interface	IInteger
Access	Read
Unit	-
Visibility	Expert
Values	≥ 0

Reads the value of the selected Counter when it was reset by a trigger or by an explicit **CounterReset** command.

It represents the last counter value latched before resetting the counter.

10.3.9 CounterDuration

Name	CounterDuration[CounterSelector]
Category	CounterAndTimerControl
Level	Recommended
Interface	IInteger
Access	Read/Write

Unit	-
Visibility	Expert
Values	≥ 0

Sets the duration (or number of events) before the **CounterEnd** event is generated.

When the counter reaches the **CounterDuration** value, a **CounterEnd** event is generated, the **CounterActive** signal becomes inactive and the counter stops counting until a new trigger happens or it is explicitly reset with **CounterReset**.

10.3.10 CounterStatus

Name	CounterStatus[CounterSelector]
Category	CounterAndTimerControl
Level	Recommended
Interface	IEnumeration
Access	Read
Unit	-
Visibility	Expert
Values	CounterIdle CounterTriggerWait CounterActive CounterCompleted CounterOverflow

Returns the current status of the Counter.

Possible values are:

- **CounterIdle**: The counter is idle.
- **CounterTriggerWait**: The counter is waiting for a start trigger.
- **CounterActive**: The counter is counting for the specified duration.
- **CounterCompleted**: The counter reached the **CounterDuration** count.
- **CounterOverflow**: The counter reached its maximum possible count.

10.3.11 CounterTriggerSource

Name	CounterTriggerSource[CounterSelector]
Category	CounterAndTimerControl

Level	Recommended
Interface	IEnumeration
Access	Read/Write
Unit	-
Visibility	Expert
Values	<p>Off</p> <p>AcquisitionTrigger</p> <p>AcquisitionTriggerMissed</p> <p>AcquisitionStart</p> <p>AcquisitionEnd</p> <p>FrameTrigger</p> <p>FrameTriggerMissed</p> <p>FrameStart</p> <p>FrameEnd</p> <p>FrameBurstStart</p> <p>FrameBurstEnd</p> <p>LineTrigger</p> <p>LineTriggerMissed</p> <p>LineStart</p> <p>LineEnd</p> <p>ExposureStart</p> <p>ExposureEnd</p> <p>Line0 (If 0 based), Line1, Line2, ...</p> <p>UserOutput0, UserOutput1, UserOutput2,...</p> <p>Counter0Start (If 0 based), Counter1Start, Counter2Start, ...</p> <p>Counter0End (if 0 based), Counter1End, Counter2End, ...</p> <p>Timer0Start (If 0 based), Timer1Start, Timer2Start, ...</p> <p>Timer0End (if 0 based), Timer1End, Timer2End, ...</p> <p>Encoder0 (if 0 based), Encoder1, Encoder2, ...</p> <p>LogicBlock0 (if 0 based), LogicBlock1, LogicBlock2, ...</p> <p>SoftwareSignal0 (If 0 based), SoftwareSignal1, SoftwareSignal2, ...</p> <p>Action0, Action1, Action2, ...</p> <p>LinkTrigger0, LinkTrigger1, LinkTrigger2, ...</p>

Selects the source to start the Counter.

Possible values are:

- **Off**: Disables the Counter trigger.
- **AcquisitionTrigger**: Starts with the reception of the Acquisition Trigger.
- **AcquisitionTriggerMissed**: Device has missed an Acquisition start trigger.
- **AcquisitionStart**: Starts with the reception of the Acquisition Start.
- **AcquisitionEnd**: Starts with the reception of the Acquisition End.
- **FrameTrigger**: Starts with the reception of the Frame Start Trigger.
- **FrameTriggerMissed**: Device has missed a Frame start trigger.
- **FrameStart**: Starts with the reception of the Frame Start.
- **FrameEnd**: Starts with the reception of the Frame End.
- **FrameBurstStart**: Starts with the reception of the Frame Burst Start.
- **FrameBurstEnd**: Starts with the reception of the Frame Burst End.
- **LineTrigger**: Starts with the reception of the Line Start Trigger.
- **LineTriggerMissed**: Device has missed a Line start trigger.
- **LineStart**: Starts with the reception of the Line Start.
- **LineEnd**: Starts with the reception of the Line End.
- **ExposureStart**: Starts with the reception of the Exposure Start.
- **ExposureEnd**: Starts with the reception of the Exposure End.
- **Line0** (If 0 based), **Line1**, **Line2**, ...: Starts when the specified CounterTriggerActivation condition is met on the chosen I/O Line.
- **UserOutput0**, **UserOutput1**, **UserOutput2**, ...: Specifies which User Output bit signal to use as internal source for the trigger.
- **Counter0Start**, **Counter1Start**, **Counter2Start**, ...: Starts with the reception of the Counter Start.
- **Counter0End**, **Counter1End**, **Counter2End**, ...: Starts with the reception of the Counter End.
- **Timer0Start**, **Timer1Start**, **Timer2Start**, ...: Starts with the reception of the Timer Start.
- **Timer0End**, **Timer1End**, **Timer2End**, ...: Starts with the reception of the Timer End.
- **Encoder0**, **Encoder1**, **Encoder2**, ...: Starts with the reception of the Encoder output signal.
- **LogicBlock0** (if 0 based), **LogicBlock1**, **LogicBlock2**, ...: Starts with the reception of the Logic Block output signal.
- **SoftwareSignal0**, **SoftwareSignal1**, **SoftwareSignal2**, ...: Starts on the reception of the Software Signal.

- **Action0, Action1, Action2, ...:** Starts with the assertion of the chosen action signal.
- **LinkTrigger0, LinkTrigger1, LinkTrigger2, ...:** Starts with the reception of the chosen Link Trigger signal.

10.3.12 CounterTriggerActivation

Name	CounterTriggerActivation[CounterSelector]
Category	CounterAndTimerControl
Level	Recommended
Interface	IEnumeration
Access	Read/Write
Unit	-
Visibility	Expert
Values	RisingEdge FallingEdge AnyEdge LevelHigh LevelLow

Selects the activation mode of the trigger to start the Counter.

Possible values are:

- **RisingEdge:** Starts counting on the Rising Edge of the selected trigger signal.
- **FallingEdge:** Starts counting on the Falling Edge of the selected trigger signal.
- **AnyEdge:** Starts counting on the Falling or rising Edge of the selected trigger signal.
- **LevelHigh:** Counts as long as the selected trigger signal level is High.
- **LevelLow:** Counts as long as the selected trigger signal level is Low.

10.4 Timer usage model

This section describes the Timers usage model.

Timers are readable and can be used to measure the duration of internal or external signals. Timers can be cascaded to increase their range if necessary. A Timer can also be used to generate a timed strobe pulse with an optional delay before activation.

To set the destination output Line of the Timer pulse, see for example **Timer1Active** entry of the **LineSource** feature.

Note that Timers can also be used to generate an Event when a predetermined maximum value (or duration) is reached. See the **EventSelector** feature.

Below we show examples of typical use cases of timer's control features in C/C++ pseudo-code.

For simplicity, the object name is omitted (e.g. **TimerValue** instead of **Camera.TimerValue**) and the default state of the device is assumed.

/* Generates a 300 us strobe pulse coming from the Timer 1 when a rising edge trigger is detected on the physical Line 2 of the device connector.

*/

```

TimerSelector      = Timer1;
TimerDuration      = 300;
TimerTriggerActivation = RisingEdge;
TimerTriggerSource  = Line2;
  
```

/* Generates a 200us Timer pulse (Strobe) delayed by 100 us on the physical output Line 2. The Timer pulse is started using a trigger coming from physical input Line 1.

*/

```

TimerSelector      = Timer1;
TimerDuration      = 200;
TimerDelay         = 100;
TimerTriggerSource  = Line1;
TimerTriggerActivation = RisingEdge;

LineSelector       = Line2;
LineMode           = Output;
LineSource         = Timer1Active;
  
```

/* Use of a Timer to measure the length in microseconds of a negative pulse on the physical input Line1. An Event is also generated to the host application to signal the end of the pulse.

*/

```
TimerSelector          = Timer1;
TimerTrigger          = Linel;
TimerTriggerActivation = LevelLow;

Register(Camera.EventLinelRisingEdge, CallbackDataObject, CallbackFunctionPtr)
EventSelector         = LinelRisingEdge;
EventNotifications    = On;

/* Wait for the event on the host to read the time. */

...

TimerSelector          = Timer1;
PulseDuration          = TimerValue;
```

10.5 Timer features

This section describes the Timers features.

10.5.1 TimerSelector

Name	TimerSelector
Category	CounterAndTimerControl
Level	Recommended
Interface	IEnumeration
Access	Read/Write
Unit	-
Visibility	Expert
Values	Timer0 (if 0 based), Timer1, Timer2, ...

Selects which Timer to configure.

Possible values are:

- **Timer0:** Selects the Timer 0.
- **Timer1:** Selects the Timer 1.
- **Timer2:** Selects the Timer 2.

10.5.2 TimerDuration

Name	TimerDuration[TimerSelector]
Category	CounterAndTimerControl
Level	Recommended
Interface	IFloat
Access	Read/Write
Unit	us
Visibility	Expert
Values	≥ 0

Sets the duration (in microseconds) of the Timer pulse.

When the Timer reaches the **TimerDuration** value, a **TimerEnd** event is generated, the **TimerActive** signal becomes low and the Timer stops counting until a new trigger happens or it is explicitly reset with **TimerReset**.

10.5.3 TimerDelay

Name	TimerDelay[TimerSelector]
Category	CounterAndTimerControl
Level	Recommended
Interface	IFloat
Access	Read/Write
Unit	us
Visibility	Expert
Values	≥ 0

Sets the duration (in microseconds) of the delay to apply at the reception of a trigger before starting the Timer.

10.5.4 TimerReset

Name	TimerReset[TimerSelector]
Category	CounterAndTimerControl
Level	Recommended
Interface	ICommand
Access	(Read)/Write
Unit	-
Visibility	Expert
Values	-

Does a software reset of the selected timer and starts it. The timer starts immediately after the reset unless a timer trigger is active.

10.5.5 TimerValue

Name	TimerValue[TimerSelector]
Category	CounterAndTimerControl
Level	Recommended
Interface	IFloat
Access	Read/Write
Unit	us
Visibility	Expert

Values	≥ 0
---------------	----------

Reads or writes the current value (in microseconds) of the selected Timer.

Writing **TimerValue** is typically used to set the start value.

10.5.6 TimerStatus

Name	TimerStatus[TimerSelector]
Category	CounterAndTimerControl
Level	Recommended
Interface	IEnumeration
Access	Read
Unit	-
Visibility	Expert
Values	TimerIdle TimerTriggerWait TimerActive TimerCompleted

Returns the current status of the Timer.

Possible values are:

- **TimerIdle**: The Timer is idle.
- **TimerTriggerWait**: The Timer is waiting for a start trigger.
- **TimerActive**: The Timer is counting for the specified duration.
- **TimerCompleted**: The Timer reached the **TimerDuration** count.

10.5.7 TimerTriggerSource

Name	TimerTriggerSource[TimerSelector]
Category	CounterAndTimerControl
Level	Recommended
Interface	IEnumeration
Access	Read/Write
Unit	-
Visibility	Expert

Values	
	Off
	AcquisitionTrigger
	AcquisitionTriggerMissed
	AcquisitionStart
	AcquisitionEnd
	FrameTrigger
	FrameTriggerMissed
	FrameStart
	FrameEnd
	FrameBurstStart
	FrameBurstEnd
	LineTrigger
	LineTriggerMissed
	LineStart
	LineEnd
	ExposureStart
	ExposureEnd
	Line0 (If 0 based), Line1, Line2,...
	UserOutput0, UserOutput1, UserOutput2,...
	Counter0Start (If 0 based), Counter1Start, Counter2Start, ...
	Counter0End (If 0 based), Counter1End, Counter2End, ...
	Timer0Start (If 0 based), Timer1Start, Timer2Start, ...
	Timer0End (If 0 based), Timer1End, Timer2End, ...
	Encoder0(if 0 based), Encoder1, Encoder2, ...
	LogicBlock0 (if 0 based), LogicBlock1, LogicBlock2, ...
	SoftwareSignal0 (If 0 based), SoftwareSignal1, SoftwareSignal2, ...
	Action0 (If 0 based), Action1, Action2, ...
	LinkTrigger0, LinkTrigger1, LinkTrigger2, ...

Selects the source of the trigger to start the Timer.

Possible values are:

- **Off:** Disables the Timer trigger.
- **AcquisitionTrigger:** Starts with the reception of the Acquisition Trigger.
- **AcquisitionTriggerMissed:** Starts with the reception of a missed Acquisition Trigger.
- **AcquisitionStart:** Starts with the reception of the Acquisition Start.
- **AcquisitionEnd:** Starts with the reception of the Acquisition End.
- **FrameTrigger:** Starts with the reception of the Frame Start Trigger.
- **FrameTriggerMissed:** Starts with the reception of a missed Frame Trigger.
- **FrameStart:** Starts with the reception of the Frame Start.

- **FrameEnd**: Starts with the reception of the Frame End.
- **FrameBurstStart**: Starts with the reception of the Frame Burst Start.
- **FrameBurstEnd**: Starts with the reception of the Frame Burst End.
- **LineTrigger**: Starts with the reception of the Line Start Trigger.
- **LineTriggerMissed**: Starts with the reception of a missed Line Trigger.
- **LineStart**: Starts with the reception of the Line Start.
- **LineEnd**: Starts with the reception of the Line End.
- **ExposureStart**: Starts with the reception of the Exposure Start.
- **ExposureEnd**: Starts with the reception of the Exposure End.
- **Line0** (If 0 based), **Line1**, **Line2**, ...: Starts when the specified TimerTriggerActivation condition is met on the chosen I/O Line.
- **UserOutput0**, **UserOutput1**, **UserOutput2**, ...: Specifies which User Output bit signal to use as internal source for the trigger.
- **Counter0Start**, **Counter1Start**, **Counter2Start**, ...: Starts with the reception of the Counter Start.
- **Counter0End**, **Counter1End**, **Counter2End**, ...: Starts with the reception of the Counter End.
- **Timer0Start**, **Timer1Start**, **Timer2Start**, ...: Starts with the reception of the Timer Start.
- **Timer0End**, **Timer1End**, **Timer2End**, ...: Starts with the reception of the Timer End. Note that a timer can retrigger itself to achieve a free running Timer.
- **Encoder0**, **Encoder1**, **Encoder2**, ...: Starts with the reception of the Encoder output signal.
- **LogicBlock0**, **LogicBlock1**, **LogicBlock2**, ...: Starts with the reception of the Logic Block output signal.
- **SoftwareSignal0**, **SoftwareSignal1**, **SoftwareSignal2**, ...: Starts on the reception of the Software Signal.
- **Action0**, **Action1**, **Action2**, ...: Starts with the assertion of the chosen action signal.
- **LinkTrigger0**, **LinkTrigger1**, **LinkTrigger2**, ...: Starts with the reception of the chosen Link Trigger.

10.5.8 TimerTriggerActivation

Name	TimerTriggerActivation[TimerSelector]
Category	CounterAndTimerControl
Level	Recommended
Interface	IEnumeration
Access	Read/Write
Unit	-

Visibility	Expert
Values	RisingEdge FallingEdge AnyEdge LevelHigh LevelLow

Selects the activation mode of the trigger to start the Timer.

Possible values are:

- **RisingEdge**: Starts counting on the Rising Edge of the selected trigger signal.
- **FallingEdge**: Starts counting on the Falling Edge of the selected trigger signal.
- **AnyEdge**: Starts counting on the Falling or Rising Edge of the selected trigger signal.
- **LevelHigh**: Counts as long as the selected trigger signal level is High.
- **LevelLow**: Counts as long as the selected trigger signal level is Low.

10.5.9 TimerTriggerArmDelay

Name	TimerTriggerArmDelay[TimerSelector]
Category	CounterAndTimerControl
Level	Recommended
Interface	IFloat
Access	Read/Write
Unit	us
Visibility	Expert
Values	≥ 0

Sets the duration of the delay to apply before to enable the reception of a new Timer trigger. This guarantees a minimum period between 2 timer triggers (used mainly for lighting control).

11 Encoder Control

This chapter lists all features that relates to control and monitoring of quadrature encoders. Quadrature encoders are also known as incremental, rotary and shaft encoders.

11.1 Quadrature Encoder usage model

This section describes the quadrature encoder usage model.

The Encoder Control interface connects to a rotary or linear quadrature encoder device which has output signals A and B used for tracking of positive and negative direction motion of the tracked axle or surface, respectively.

The Encoder Control interface uses a position counter driven by the A and B signals to track the position of the target in the presence of either a positive or a negative direction of motion.

The Encoder interface can generate a trigger signal to the sensor via **TriggerSource** while maintaining its counter value for tracking the position of the object. This means that reading the counter value gives the position and motion of the quadrature encoder (target object) from the time the position encoder started. Starting the position counter can be done with **AcquisitionStart** through the **EncoderResetSource**.

The number of input pulses from a quadrature encoder needed to generate Encoder Control output pulses, which can be used as a trigger source (i.e. the distance between samples along the encoder motion) is controlled via the **EncoderDivider** feature. The position counter runs continuously and its value represents the number of incoming pulses received since the last reset. Thus, this counter always reflects the true position of the object before the divider. The **EncoderOutputMode** feature is then used to control how the position counter generates its output signal.

Some quadrature encoders have an index output that indicates their per revolution position; however, this is not included explicitly in the Encoder Control interface. This signal can be handled through the standard I/O interface as a separate signal for example to reset of the Encoder Control position counter.

Quadrature encoder outputs often use differential signaling, but this conditioning is also handled by the generic I/O setup.

Note that the Encoder Control output can also be used to generate Events (See the **EventSelector** feature).

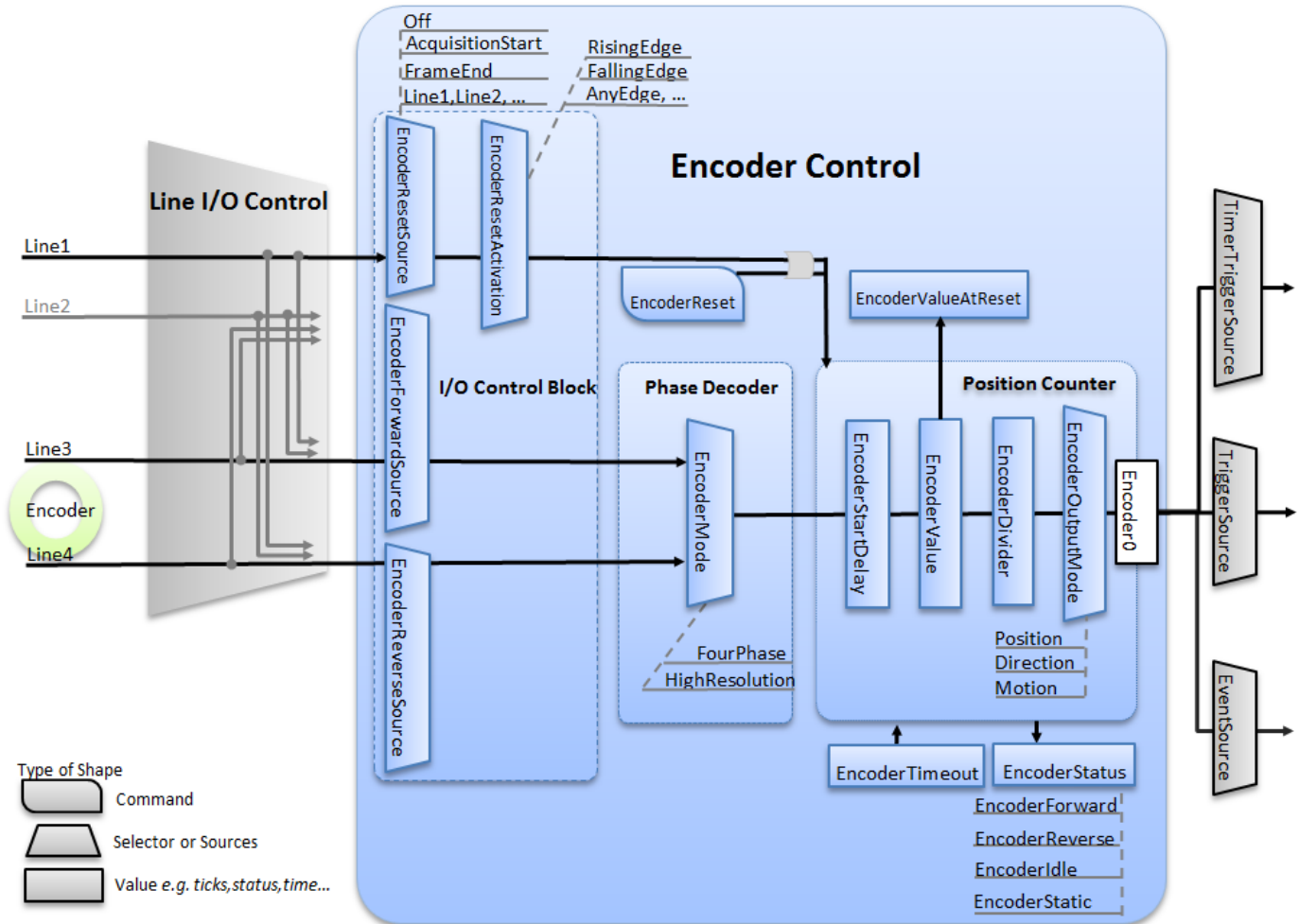

Figure 11-1: Encoder interface overview.

Encoder Output Modes:

With a quadrature encoder connected it is possible to use the Encoder Control output to trigger the camera in several ways when the motion moves forwards and backwards. The illustration below shows 3 different Encoder Output Modes. The Position and Direction modes can both work in "up" and "down" counting directions to allow the user to select a positive or negative direction.

The **Position** mode generates output pulses on position increments only in one direction and will result in an image as if there was only forward motion even if the motion reverse for a short time. No output pulses are generated until after the position where the reversal started has passed. The position "memory" (counter resolution) must be sufficient to handle a reasonable reversal without false "reset".

The **Direction** mode generates output pulses on position increments only in one direction. This mode can be used to trigger a camera in an application where the reverse motion is ignored. For a linear stage moving back and forth, output pulses will be generated only in one direction.

The **Motion** mode generates output pulses on position increments in both directions. This mode can in some implementations be achieved by connecting only one signal (A or B) from the quadrature encoder to the Encoder Control interface.

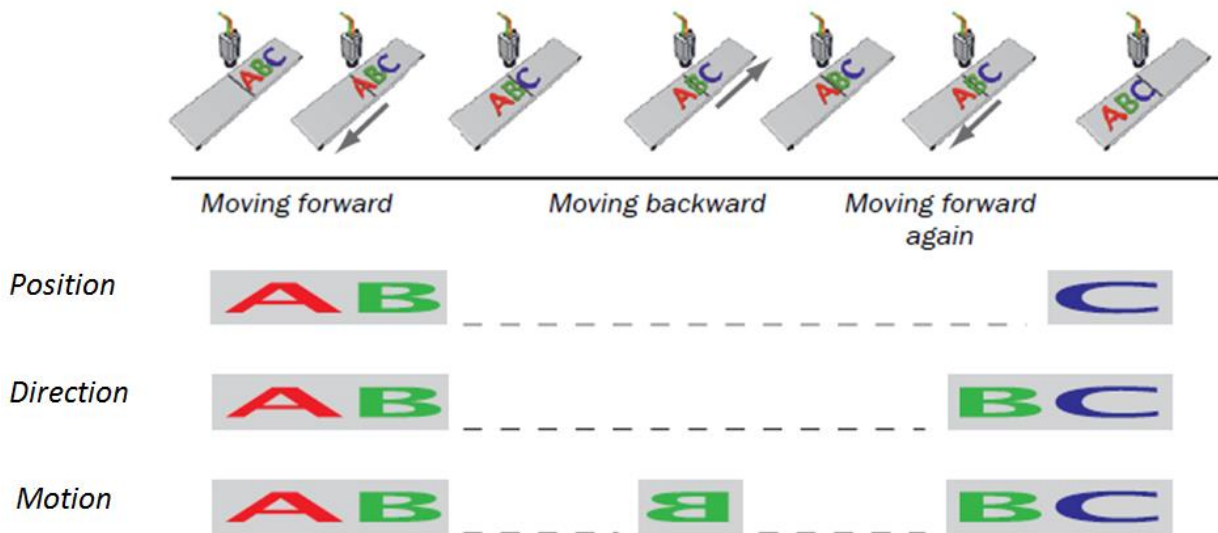

Figure 11-2: Encoder position, direction and motion output modes.

Encoder Modes:

The encoder mode controls how the EncoderValue is calculated as function of the encoder inputs. The EncoderValue always tracks the encoder motion forward and backwards and is the input for the Encoder Output Mode functionality.

Robust Four phases motion tracking

There are 4 possible states from the two input signals and their transitions can be viewed in a state diagram as shown below. With this strategy, a small amount of jitter between two states from the quadrature encoder will be filtered. All transitions from the 00 quadrature encoder state sets the direction state to Pos or Neg. Counter increments or decrements only occur when entering the 00 state. Increments or decrements can only occur when the direction state is positive (Pos) or negative (Neg), respectively as seen in the figure.

Note that Quadrature encoders follow the Gray Code binary numeral system where only 1-bit changes between states. Therefore, transitions where 2 bits change are illegal such as between states 01 and 10, and 00 and 11. Illegal state changes can be filtered thereby reducing jitter for both Four Phase and High Resolution modes.

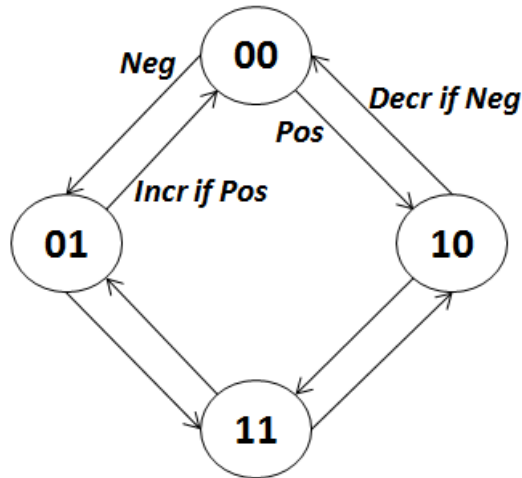

Figure 11-3: Encoder 4 states up and down counting.

High resolution motion tracking

In some applications, a higher resolution is required, but this will be available without jitter filtering. In this case the counter can increment or decrement for each of the quadrature phases in the state diagram as illustrated below. This mode supports all Encoder Control output modes, but is not recommended in the Motion mode since jitter between two states may result in continuous output pulses.

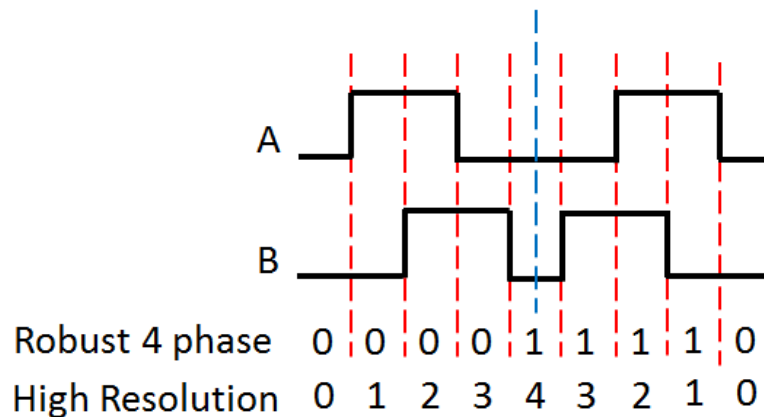

Figure 11-4: Encoder Control interface and EncoderValue in both motion tracking modes.

Motion Tracking Direction:

The Encoder Control interface use an A and a B **EncoderSource** input connected to the quadrature encoder outputs. These typically correspond to the A and B labelled outputs on the quadrature encoder. The direction of

the motion will increment or decrement the position counter. The user can select Up or Down counting for the Position and Direction modes.

Encoder Status:

The Encoder Status reflects if the encoder is active or not, and can be used for instance to create an event if the encoder stops receiving input pulses for a predefined timeout time, or as "wakeup" when it restarts its motion after a timeout.

Encoder real world translation:

The encoder information can convey real world distance and displacement if the step size of the encoder is used. For 3D cameras the Scan3dCoordinateScale can be used for this purpose.

Encoder counter wrap around:

If the position counter is running continuously it will wrap around between its maximum and minimum values if moving in positive and negative directions.

The position for wrap-around should be readable for the application through the Min and Max values of the **EncoderValue** feature.

This means that the application using the **EncoderValue** of a scan to track large displacements needs to use the wrap around limits and use corrective calculations when calculating the true displacement. For instance, when a sudden jump from ~encoder max to ~encoder min is observed in the encoder value the receiver can easily correct the true displacement by adding a full position counter (encodermax-encodermin+1) to the result. As long as the range of the position counter is much larger than the delta between individual encoder values for scans this method works well.

Example of Encoder setup:

```
// Encoder Setup
EncoderSelector           = Encoder0;
EncoderSourceA[Encoder0] = Line0;
EncoderSourceB[Encoder0] = Line1;
EncoderMode[Encoder0]    = FourPhase;
EncoderDivider[Encoder0] = 10;
EncoderOutputMode[Encoder0] = PositionUp;
```

To set the destination output Line of the Encoder module, see **Encoder** entries of the **LineSource** feature.

11.2 Encoder features

This section describes the quadrature encoder features.

11.2.1 EncoderControl

Name	EncoderControl
Category	Root
Level	Optional
Interface	ICategory
Access	Read
Unit	-
Visibility	Beginner
Values	-

Category that contains the quadrature Encoder Control features.

11.2.2 EncoderSelector

Name	EncoderSelector
Category	EncoderControl
Level	Optional
Interface	IEnumeration
Access	Read/Write
Unit	-
Visibility	Expert
Values	Encoder0 (If 0 based), Encoder1, Encoder2, ...

Selects which Encoder to configure.

Possible values are:

- **Encoder0:** Selects Encoder 0.
- **Encoder1:** Selects Encoder 1.
- **Encoder2:** Selects Encoder 2.
- ...

11.2.3 EncoderSourceA

Name	EncoderSourceA[EncoderSelector]
Category	EncoderControl
Level	Optional
Interface	IEnumeration
Access	Read/Write
Unit	-
Visibility	Expert
Values	Off Line0 (If 0 based), Line1, Line2,

Selects the signal which will be the source of the A input of the Encoder.

Possible values are:

- **Off:** Counter is stopped.
- **Line0, Line1, Line2, ...:** Encoder Forward input is taken from the chosen I/O Line.
- ...

11.2.4 EncoderSourceB

Name	EncoderSourceB[EncoderSelector]
Category	EncoderControl
Level	Optional
Interface	IEnumeration
Access	Read/Write
Unit	-
Visibility	Expert
Values	Off Line0 (If 0 based), Line1, Line2,

Selects the signal which will be the source of the B input of the Encoder.

Possible values are:

- **Off:** Counter is stopped.
- **Line0, Line1, Line2, ...:** Encoder Reverse input is taken from the chosen I/O Line.

- ...

11.2.5 EncoderMode

Name	EncoderMode[EncoderSelector]
Category	EncoderControl
Level	Optional
Interface	IEnumeration
Access	Read/Write
Unit	-
Visibility	Expert
Values	FourPhase HighResolution

Selects if the count of encoder uses FourPhase mode with jitter filtering or the HighResolution mode without jitter filtering.

Possible values are:

- **FourPhase:** The counter increments or decrements 1 for every full quadrature cycle with jitter filtering.
- **HighResolution:** The counter increments or decrements every quadrature phase for high resolution counting, but without jitter filtering.

11.2.6 EncoderDivider

Name	EncoderDivider[EncoderSelector]
Category	EncoderControl
Level	Optional
Interface	IInteger
Access	Read/Write
Unit	-
Visibility	Expert
Values	> 0

Sets how many Encoder increment/decrements are needed to generate an Encoder output pulse signal.

11.2.7 EncoderOutputMode

Name	EncoderOutputMode[EncoderSelector]
Category	EncoderControl
Level	Optional
Interface	IEnumeration
Access	Read/Write
Unit	-
Visibility	Expert
Values	Off PositionUp PositionDown DirectionUp DirectionDown Motion

Selects the conditions for the Encoder interface to generate a valid Encoder output signal.

Possible values are:

- **Off:** No output pulse are generated.
- **PositionUp:** Output pulses are generated at all new positions in the positive direction. If the encoder reverses no output pulse are generated until it has again passed the position where the reversal started.
- **PositionDown:** Output pulses are generated at all new positions in the negative direction. If the encoder reverses no output pulse are generated until it has again passed the position where the reversal started.
- **DirectionUp:** Output pulses are generated at all position increments in the positive direction while ignoring negative direction motion.
- **DirectionDown:** Output pulses are generated at all position increments in the negative direction while ignoring positive direction motion.
- **Motion:** Output pulses are generated at all motion increments in both directions.

11.2.8 EncoderStatus

Name	EncoderStatus[EncoderSelector]
Category	EncoderControl
Level	Optional
Interface	IEnumeration
Access	Read
Unit	-

Visibility	Expert
Values	EncoderUp EncoderDown EncoderIdle EncoderStatic

Returns the motion status of the encoder.

Possible values are:

- **EncoderUp:** The encoder counter last incremented.
- **EncoderDown:** The encoder counter last decremented.
- **EncoderIdle:** The encoder is not active.
- **EncoderStatic:** No motion within the EncoderTimeout time.

11.2.9 EncoderTimeout

Name	EncoderTimeout[EncoderSelector]
Category	EncoderControl
Level	Optional
Interface	IFloat
Access	Read/Write
Unit	us
Visibility	Expert
Values	> 0

Sets the maximum time interval between encoder counter increments before the status turns to static.

11.2.10 EncoderResetSource

Name	EncoderResetSource[EncoderSelector]
Category	EncoderControl
Level	Recommended
Interface	IEnumeration
Access	Read/Write
Unit	-
Visibility	Expert

Values	
	Off
	AcquisitionTrigger
	AcquisitionTriggerMissed
	AcquisitionStart
	AcquisitionEnd
	FrameTrigger
	FrameTriggerMissed
	FrameStart
	FrameEnd
	ExposureStart
	ExposureEnd
	Line0 (If 0 based), Line1, Line2, ...
	UserOutput0, UserOutput1, UserOutput2,...
	Counter0Start (If 0 based), Counter1Start, Counter2Start, ...
	Counter0End (If 0 based), Counter1End, Counter2End, ...
	Timer0Start (If 0 based), Timer1Start, Timer2Start, ...
	Timer0End (If 0 based), Timer1End, Timer2End, ...
	LogicBlock0 (If 0 based), LogicBlock1, LogicBlock2, ...
	SoftwareSignal0 (If 0 based), SoftwareSignal1, SoftwareSignal2, ...
	Action0 (If 0 based), Action1, Action2, ...
	LinkTrigger0 (If 0 based), LinkTrigger1, LinkTrigger2, ...

Selects the signals that will be the source to reset the Encoder.

Possible values are:

- **Off:** Disable the Encoder Reset trigger.
- **AcquisitionTrigger:** Resets with the reception of the Acquisition Trigger.
- **AcquisitionTriggerMissed:** Resets with the reception of a missed Acquisition Trigger.
- **AcquisitionStart:** Resets with the reception of the Acquisition Start.
- **AcquisitionEnd:** Resets with the reception of the Acquisition End.
- **FrameTrigger:** Resets with the reception of the Frame Start Trigger.
- **FrameTriggerMissed:** Resets with the reception of a missed Frame Trigger.

- **FrameStart**: Resets with the reception of the Frame Start.
- **FrameEnd**: Resets with the reception of the Frame End.
- **FrameBurstStart**: Resets with the reception of the Frame Burst Start.
- **FrameBurstEnd**: Resets with the reception of the Frame Burst End.
- **ExposureStart**: Resets with the reception of the Exposure Start.
- **ExposureEnd**: Resets with the reception of the Exposure End.
- **Line0** (If 0 based), **Line1**, **Line2**, ...: Resets by the chosen I/O Line.
- **UserOutput0**, **UserOutput1**, **UserOutput2**, ...: Resets by the chosen User Output bit.
- **Counter0Start**, **Counter1Start**, **Counter2Start**, ...: Resets with the reception of the Counter Start.
- **Counter0End**, **Counter1End**, **Counter2End**, ...: Resets with the reception of the Counter End.
- **Timer0Start**, **Timer1Start**, **Timer2Start**, ...: Resets with the reception of the Timer Start.
- **Timer0End**, **Timer1End**, **Timer2End**, ...: Resets with the reception of the Timer End.
- **LogicBlock0**, **LogicBlock1**, **LogicBlock2**, ...: Reset by the chosen Logic Block signal.
- **SoftwareSignal0**, **SoftwareSignal1**, **SoftwareSignal2**, ...: Resets on the reception of the Software Signal.
- **Action0**, **Action1**, **Action2**, ...: Resets on assertions of the chosen action signal (Broadcasted signal on the transport layer).
- **LinkTrigger0**, **LinkTrigger1**, **LinkTrigger2**, ...: Resets on the reception of the chosen Link Trigger (received from the transport layer).

Note that the value of the Encoder counter at time of reset is automatically latched and reflected in **EncoderValueAtReset**.

11.2.11 EncoderResetActivation

Name	EncoderResetActivation[EncoderSelector]
Category	EncoderControl
Level	Recommended
Interface	IEnumeration
Access	Read/Write
Unit	-
Visibility	Expert
Values	RisingEdge FallingEdge AnyEdge LevelHigh

LevelLow

Selects the Activation mode of the Encoder Reset Source signal.

Possible values are:

- **RisingEdge**: Resets the Encoder on the Rising Edge of the signal.
- **FallingEdge**: Resets the Encoder on the Falling Edge of the signal.
- **AnyEdge**: Resets the Encoder on the Falling or rising Edge of the selected signal.
- **LevelHigh**: Resets the Encoder as long as the selected signal level is High.
- **LevelLow**: Resets the Encoder as long as the selected signal level is Low.

11.2.12 EncoderReset

Name	EncoderReset[EncoderSelector]
Category	EncoderControl
Level	Recommended
Interface	ICommand
Access	(Read)/Write
Unit	-
Visibility	Expert
Values	-

Does a software reset of the selected Encoder and starts it. The Encoder starts counting events immediately after the reset. EncoderReset can be used to reset the Encoder independently from the EncoderResetSource.

Note that the value of the Encoder at time of reset is automatically latched and reflected in the **EncoderValueAtReset**.

11.2.13 EncoderValue

Name	EncoderValue[EncoderSelector]
Category	EncoderControl
Level	Recommended
Interface	IInteger
Access	Read/Write
Unit	-
Visibility	Expert

Values	-
---------------	---

Reads or writes the current value of the position counter of the selected Encoder.

Writing to **EncoderValue** is typically used to set the start value of the position counter.

11.2.14 EncoderValueAtReset

Name	EncoderValueAtReset[EncoderSelector]
Category	EncoderControl
Level	Recommended
Interface	IInteger
Access	Read
Unit	-
Visibility	Expert
Values	-

Reads the value of the of the position counter of the selected Encoder when it was reset by a signal or by an explicit **EncoderReset** command.

It represents the last Encoder value latched before resetting the Encoder.

12 Logic Block Control

The Logic Block Control chapter describes the model and features related to the control and the generation of signals by Logic Block elements.

A Logic Block is a general combinational logic element that performs a binary function on its inputs and can be used to condition various signal sources (internal or external). It generates an output signal according to the combinational binary equation selected. This Logic Block generates an output signal which can then be used as input source for other SFNC modules (Trigger, Timer, Counter, ...) using the names LogicBlock0, LogicBlock1, ...

A typical usage scenario could be a user that wants to control when a trigger is considered valid using external input Lines and an internal camera signal (See Example 2 below).

12.1 Logic Block usage model

Example 1

Setting of an AND logical block to start the grab if a trigger pulse is received on Line1 (Trigger) and Line 2 (Trigger Enable) is Low:

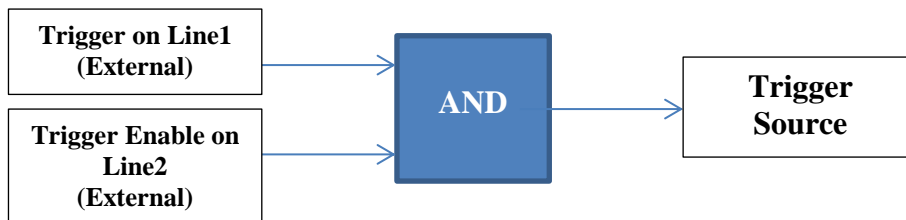

```

/* Initialize the AND Logic Block input sources. */
LogicBlockSelector      = LogicBlock0;
LogicBlockFunction[LogicBlock0] = AND;
LogicBlockInputNumber[LogicBlock0] = 2;
LogicBlockInputSelector[LogicBlock0] = 0;
LogicBlockInputSource[LogicBlock0][0] = Line1;
LogicBlockInputSelector[LogicBlock0] = 1;
LogicBlockInputSource[LogicBlock0][1] = Line2;

/* Set the AND Logic Block output as trigger source and do an acquisition. */
TriggerSelector      = FrameStart;
TriggerSource        = LogicBlock0;
TriggerActivation    = RisingEdge;
TriggerMode          = On;
AquisitionStart();
...
AquisitionEnd();
  
```

Example 2

Setting of a custom 3 inputs LUT cascaded in an AND Logic block. The LUT is cascaded in the AND Logic block to enable the trigger only if a user defined condition is meet.

The final combination would give a condition where if Exposure is not active in the camera and either Line0 or Line1 is high, a rising edge trigger on Line2 will trigger a new frame.

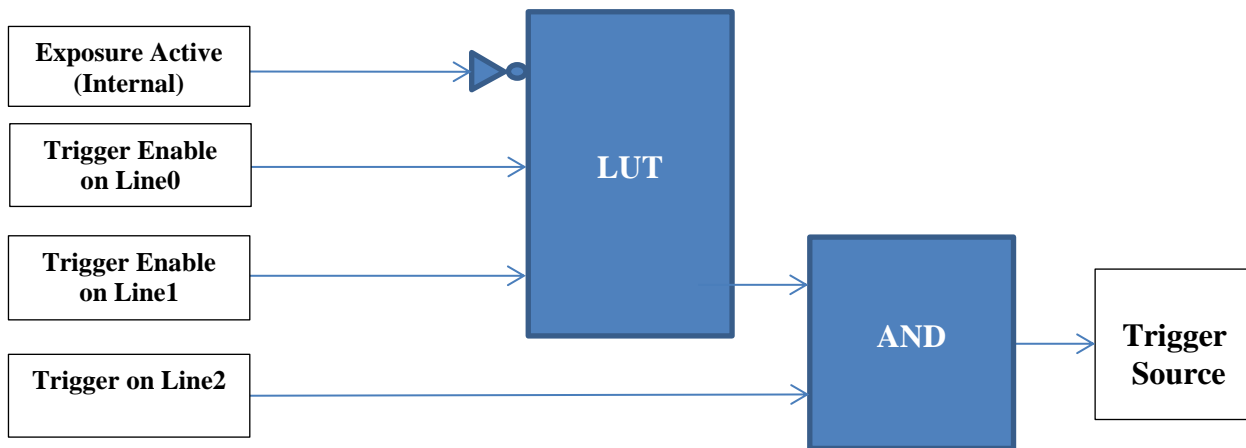

			LUT Output
2	1	0	
0	0	0	0
0	0	1	0
0	1	0	0
0	1	1	1
1	0	0	0
1	0	1	1
1	1	0	0
1	1	1	1

```

/* Initialize the LUT Logic Block input sources and output. */
LogicBlockSelector                = LogicBlock0;
LogicBlockFunction[LogicBlock0]   = LUT;
LogicBlockInputNumber[LogicBlock0] = 3;
LogicBlockLUTInputSelector[LogicBlock0] = 0;
LogicBlockLUTInputSource[LogicBlock0][0] = ExposureActive;
LogicBlockInputInverter[LogicBlock0][0] = True;
LogicBlockLUTInputSelector[LogicBlock0] = 1;
LogicBlockLUTInputSource[LogicBlock0][1] = Line0;
LogicBlockInputInverter[LogicBlock0][1] = False;
LogicBlockLUTInputSelector[LogicBlock0] = 2;
LogicBlockLUTInputSource[LogicBlock0][2] = Line1;
    
```

```

LogicBlockInputInverter[LogicBlock0][2] = False;
LogicBlockLUTValueAll[LogicBlock0]     = 0xA8;

/* Initialize the AND Logic Block input sources. */
LogicBlockSelector                       = LogicBlock1;
LogicBlockFunction[LogicBlock1]         = AND;
LogicBlockInputNumber[LogicBlock1]      = 2;
LogicBlockInputSelector[LogicBlock1]    = 0;
LogicBlockInputSource[LogicBlock1][0]  = LogicBlock0;
LogicBlockInputSelector[LogicBlock1]    = 1;
LogicBlockInputSource[LogicBlock1][1]  = Line2;

/* Set the cascaded Logic Blocks as the trigger source and start the acquisition. */
TriggerSelector                         = FrameStart;
TriggerSource[FrameStart]               = LogicBlock1;
TriggerActivation[FrameStart]           = RisingEdge;
TriggerMode[FrameStart]                 = On;
AquisitionStart();
...
AquisitionEnd();
    
```

Example 3

Setting of a custom Latched dual LUTs Logical Block counting the number of triggers that occur when FrameTriggerWait is not active (i.e. Over trigger counting).

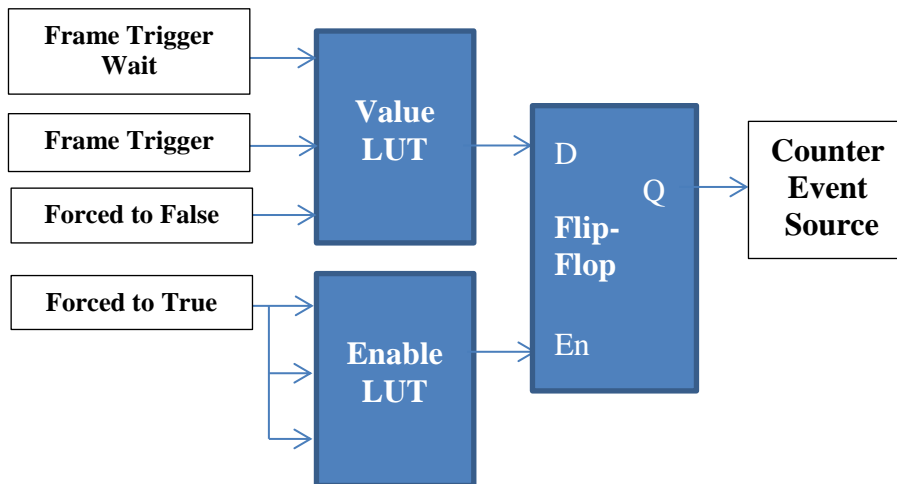

Input			Value LUT Output
2	1	0	
0	0	0	0
0	0	1	0
0	1	0	0
0	1	1	1

Input			Enable LUT Output
2	1	0	
1	0	0	1
1	0	1	1
1	1	0	1
1	1	1	1

Input		Q Next Output
D	En	
0	0	Q Previous
0	1	0
1	0	Q previous
1	1	1

```

/* Select the Latch dual LUTs Logic Block. */
LogicBlockSelector                = LogicBlock0;
LogicBlockFunction[LogicBlock0]   = LatchedLUT;

/* Initialize the Value LUT of the Logic Block. */
LogicBlockLUTSelector             = Value;
LogicBlockInputNumber[LogicBlock0][value] = 3;
LogicBlockInputSelector[LogicBlock0][Value] = 0;
LogicBlockInputSource[LogicBlock0][Value][0] = FrameTriggerWait;
LogicBlockInputActivation[LogicBlock0][Value][0] = LevelLow;
LogicBlockInputSelector[LogicBlock0][Value] = 1;
LogicBlockInputSource[LogicBlock0][Value][1] = FrameTrigger;
LogicBlockInputActivation[LogicBlock0][Value][1] = RisingEdge;
LogicBlockInputSelector[LogicBlock0][Value] = 2;
LogicBlockInputSource[LogicBlock0][Value][2] = False;
LogicBlockLUTValueAll[LogicBlock0][Value][2] = 0x08;

/* Initialize the Enable LUT of the Logic Block (output always 1). */
LogicBlockLUTSelector[LogicBlock0] = Enable;
LogicBlockInputNumber[LogicBlock0][Enable] = 3;
LogicBlockInputSelector[LogicBlock0][Enable] = 0;
LogicBlockInputSource[LogicBlock0][Enable][2] = True;
LogicBlockInputSelector[LogicBlock0][Enable] = 1;
LogicBlockInputSource[LogicBlock0][Enable][2] = True;
LogicBlockInputSelector[LogicBlock0][Enable] = 2;
LogicBlockInputSource[LogicBlock0][Enable][2] = True;
LogicBlockLUTValueAll[LogicBlock0][Enable] = 0xFF;

/* Set LatchedLUTs Logic Block as source to a Counter. */
CounterSelector                = Counter0;
CounterEventSource[Counter0]   = LogicBlock0;
CounterEventActivation[Counter0] = RisingEdge;
CounterResetSource[Counter0]   = AcquisitionStart;
CounterResetActivation[Counter0] = RisingEdge;

```

12.2 Logic Block Control features

This section describes the features that control the Logic Block.

12.2.1 LogicBlockControl

Name	LogicBlockControl
Category	Root
Level	Optional
Interface	ICategory
Access	Read
Unit	-

Visibility	Guru
Values	-

Category that contains the Logic Block control features.

12.2.2 LogicBlockSelector

Name	LogicBlockSelector
Category	LogicBlockControl
Level	Optional
Interface	IEnumeration
Access	Read/Write
Unit	-
Visibility	Guru
Values	LogicBlock0 (If 0 based) LogicBlock1 LogicBlock2 ...

Specifies the Logic Block to configure.

Possible values are:

- **LogicBlock0**: Logic Block 0 is selected.
- **LogicBlock1**: Logic Block 1 is selected.
- **LogicBlock2**: Logic Block 2 is selected.
- ...

12.2.3 LogicBlockFunction

Name	LogicBlockFunction[LogicBlockSelector]
Category	LogicBlockControl
Level	Optional
Interface	IEnumeration
Access	Read/Write
Unit	-

Visibility	Guru
Values	AND OR LUT LatchedLUT ...

Selects the combinational logic Function of the Logic Block to configure.

Possible values are:

- AND: Selects a Logic Block that does the logical AND of all the inputs.
- OR: Selects a Logic Block that does the logical OR of all the inputs.
- LUT: Selects a Logic Block that does a Look Up Table Transformation on all the inputs.
- LatchedLUT: Selects a Logic Block with 2 LUTs as inputs to a Flip-Flop.
- ...

12.2.4 LogicBlockInputNumber

Name	LogicBlockInputNumber[LogicBlockSelector]
Category	LogicBlockControl
Level	Optional
Interface	IInteger
Access	Read/(Write)
Unit	-
Visibility	Guru
Values	≥ 2

Specifies the number of active signal inputs of the Logic Block.

Note that this feature might be read-only for Logical blocks that have a fixed number of inputs.

12.2.5 LogicBlockInputSelector

Name	LogicBlockInputSelector[LogicBlockSelector]
Category	LogicBlockControl
Level	Optional
Interface	IInteger
Access	Read/Write

Unit	-
Visibility	Guru
Values	≥ 0

Selects the Logic Block's input to configure.

12.2.6 LogicBlockInputSource

Name	LogicBlockInputSource[LogicBlockSelector][LogicBlockInputSelector]
Category	LogicBlockControl
Level	Optional
Interface	IEnumeration
Access	Read/Write
Unit	-
Visibility	Guru
Values	True False AcquisitionTriggerWait AcquisitionTrigger AcquisitionTriggerMissed AcquisitionActive FrameTriggerWait FrameTrigger FrameTriggerMissed FrameActive ExposureActive LineTriggerWait LineTrigger LineTriggerMissed LineActive Counter0Active, Counter1Active, Counter2Active, ... Timer0Active, Timer1Active, Timer2Active, ... Encoder0, Encoder1, Encoder2, ... LogicBlock0, LogicBlock1, LogicBlock2, ... SoftwareSignal0, SoftwareSignal1, SoftwareSignal2, ... Line0, Line1, Line2, ... UserOutput0, UserOutput1, UserOutput2, ... Stream0TransferActive, Stream1TransferActive, ... Stream0TransferPaused, Stream1TransferPaused, ... Stream0TransferStopping, Stream1TransferStopping, ... Stream0TransferStopped, Stream1TransferStopped, ...

Stream0TransferOverflow, Stream1TransferOverflow, ...

Selects the source signal for the input into the Logic Block. True or False indicates the input is forced constant.

Possible values are:

- **True:** Logic Block input is forced to One.
- **False:** Logic Block input is forced to Zero.
- **AcquisitionTriggerWait:** Device is currently waiting for a trigger for the capture of one or many Frames.
- **AcquisitionTrigger:** Device is receiving a trigger for the capture of one or many Frames.
- **AcquisitionTriggerMissed:** Device has missed a trigger for the capture of one or many Frames.
- **AcquisitionActive:** Device is acquiring one or many Frames.
- **FrameTriggerWait:** Device is currently waiting for a Frame start trigger.
- **FrameTrigger:** Device is receiving a Frame start trigger.
- **FrameTriggerMissed:** Device has missed a Frame start trigger.
- **FrameActive:** Device is currently doing the capture of a Frame.
- **ExposureActive:** Device is doing the exposure of a Frame (or Line).
- **LineTriggerWait:** Device is currently waiting for a Line start trigger.
- **LineTrigger:** Device is receiving a Line start trigger.
- **LineTriggerMissed:** Device has missed a Line start trigger.
- **LineActive:** Device is currently doing the capture of a Line.
- **Counter0Active, Counter1Active, Counter2Active, ...:** The chosen counter is in active state (counting).
- **Timer0Active, Timer1Active, Timer2Active, ...:** The chosen Timer is in active state.
- **Encoder0, Encoder1, Encoder2, ...:** The chosen Encoder Output state.
- **LogicBlock0, LogicBlock1, LogicBlock2, ...:** The chosen Logic Block output state.
- **Line0, Line1, Line2, ...:** The chosen I/O Line state.
- **UserOutput0, UserOutput1, UserOutput2, ...:** The chosen User Output bit state as defined by its current **UserOutputValue**.
- **SoftwareSignal0, SoftwareSignal1, SoftwareSignal2, ...:** The chosen Software Signal output state.
- **Stream0TransferActive, Stream1TransferActive, ...:** Transfer on the stream is active.
- **Stream0TransferPaused, Stream1TransferPaused, ...:** Transfer on the stream is paused.
- **Stream0TransferStopping, Stream1TransferStopping, ...:** Transfer on the stream is stopping.

- **Stream0TransferStopped, Stream1TransferStopped, ...:** Transfer on the stream is stopped.
- **Stream0TransferOverflow, Stream1TransferOverflow, ...:** Transfer on the stream is in overflow.

12.2.7 LogicBlockInputInverter

Name	LogicBlockInputInverter[LogicBlockSelector][LogicBlockInputSelector]
Category	LogicBlockControl
Level	Optional
Interface	IBoolean
Access	Read/Write
Unit	-
Visibility	Guru
Values	True False

Selects if the selected Logic Block Input source signal is inverted. This feature is not available when the LogicBlockInputSource is set to True or False.

Note: When applied to a clock input, if LogicBlockInputInverter is set to False, this corresponds to a rising edge clock activation and if set to True to a falling edge activation.

Possible values are:

- True: The Logic Block Input is inverted.
- False: The Logic Block Input is not inverted.

12.2.8 LogicBlockLUTIndex

Name	LogicBlockLUTIndex[LogicBlockSelector]
Category	LogicBlockControl
Level	Optional
Interface	IInteger
Access	Read/Write
Unit	-
Visibility	Guru
Values	≥ 0

Controls the index of the truth table to access in the selected LUT.

There must always be 2^n entries in the LUT, where n is the number of input in the LUT. The index must be 0 based and row 0 refers to the entry with all inputs at logic level 0 (False). Index value of 2^n-1 refers to the entry with all inputs at logic level 1 (True).

12.2.9 LogicBlockLUTValue

Name	LogicBlockLUTValue[LogicBlockSelector][LogicBlockLUTIndex]
Category	LogicBlockControl
Level	Optional
Interface	IBoolean
Access	Read/Write
Unit	-
Visibility	Guru
Values	True False

Read or Write the Value associated with the entry at index **LogicBlockLUTIndex** of the selected LUT.

12.2.10 LogicBlockLUTValueAll

Name	LogicBlockLUTValueAll[LogicBlockSelector]
Category	LogicBlockControl
Level	Optional
Interface	IInteger
Access	Read/Write
Unit	-
Visibility	Guru
Values	≥ 0

Sets the values of all the output bits of the selected LUT in one access ignoring LogicBlockLUTIndex. LogicBlockLUTValueAll value can be any binary number and each bit correspond to the output value for the corresponding index (i.e. Bit 0 = LUT Index 0 output binary value).

12.2.11 LogicBlockLUTSelector

Name	LogicBlockLUTSelector[LogicBlockSelector]
Category	LogicBlockControl

Level	Optional
Interface	IEnumeration
Access	Read/Write
Unit	-
Visibility	Guru
Values	Value Enable

Selects which of the two LUTs to configure when the selected Logic Block is a Latched dual LUTs (i.e: LogicalBlockFunction = LatchedLUT).

- Value: Selects the LUT controlling the data input of the flip-flop.
- Enable: Selects the LUT controlling the enable input of the flip-flop.

13 Software Signal Control

The Software Signal Control chapter describes the model and features related to the control and the generation of software generated signals.

A software signal is a general source and can be used as a trigger signal source for diverse functions in other SFNC modules.

13.1 SoftwareSignalControl

Name	SoftwareSignalControl
Category	Root
Level	Optional
Interface	ICategory
Access	Read
Unit	-
Visibility	Beginner
Values	-

Category that contains the Software Signal Control features.

13.2 SoftwareSignalSelector

Name	SoftwareSignalSelector
Category	SoftwareSignalControl
Level	Optional
Interface	IEnumeration
Access	Read/Write
Unit	-
Visibility	Beginner
Values	SoftwareSignal0 (If 0 based) SoftwareSignal1, SoftwareSignal2, ...

Selects which Software Signal features to control.

Possible values are:

- **SoftwareSignal0, SoftwareSignal1, SoftwareSignal2, ...**: Selects the software generated signal to control.

13.3 SoftwareSignalPulse

Name	SoftwareSignalPulse[SoftwareSignalSelector]
Category	SoftwareSignalControl
Level	Optional
Interface	ICommand
Access	(Read)/Write
Unit	-
Visibility	Beginner
Values	-

Generates a pulse signal that can be used as a software trigger. This command can be used to trigger other modules that accept a SoftwareSignal as trigger source.

14 Action Control

The Action chapter describes all features related to Action Signals in the device.

14.1 Action usage model

Action Signals are a method to trigger actions in multiple devices at the same time (depending on the specific transport layer). Action Signals are used in the device in the same way as e.g. digital input lines.

One possible use for action signals is to raise a FrameStart trigger in multiple devices at the same time.

On most transport layers Action Signals are implemented using broadcast protocol messages. To allow a finegrained control which devices are allowed to react on the broadcasted action protocol message, the features **ActionDeviceKey**, **ActionGroupKey** and **ActionGroupMask** define filter conditions.

Each action protocol message contains an action device key, action group key and an action group mask. If the device detects a match between this protocol information and one of the actions selected by **ActionSelector** it raises the corresponding Action Signal.

Usage Examples:

/* Triggered Single Frame acquisition using the Action Signal 1. */

```

AcquisitionMode = SingleFrame;
TriggerSelector = FrameStart;
TriggerMode     = On;
TriggerSource   = Action1;

ActionDeviceKey = 0x12345678;
ActionSelector  = 1;
ActionGroupKey  = 0x1;
ActionGroupMask = 0x1;

AcquisitionStart();

// Here the Device is ready to receive the Action Command
// from an external source.

```

/* Generates a 200us Timer pulse (Strobe) on the physical output Line 2.
The Timer pulse is started using a trigger coming from Action Signal 3.
*/

```

TimerSelector          = Timer1;
TimerDuration          = 200;
TimerTriggerSource    = Action3;

LineSelector          = Line2;
LineMode              = Output;
LineSource            = Timer1Active;

ActionDeviceKey       = 0x12345678;
ActionSelector        = 3;
ActionGroupKey        = 0x1;
ActionGroupMask       = 0x7;

// Here the Device is ready to receive the Action Command
// from an external source.
    
```

14.2 Action Control Features

This section describes the action control features.

14.2.1 ActionControl

Name	ActionControl
Category	Root
Level	Recommended
Interface	ICategory
Access	Read
Unit	-
Visibility	Guru
Values	-

Category that contains the Action control features.

14.2.2 ActionUnconditionalMode

Name	ActionUnconditionalMode
Category	ActionControl
Level	Optional
Interface	IEnumeration
Access	Read/Write

Unit	-
Visibility	Guru
Values	Off On

Enables the unconditional action command mode where action commands are processed even when the primary control channel is closed.

Possible values are:

- **Off:** Unconditional mode is disabled.
- **On:** Unconditional mode is enabled.

14.2.3 ActionDeviceKey

Name	ActionDeviceKey
Category	ActionControl
Level	Optional
Interface	IInteger
Access	Write-Only
Unit	-
Visibility	Guru
Values	≥ 0

Provides the device key that allows the device to check the validity of action commands. The device internal assertion of an action signal is only authorized if the **ActionDeviceKey** and the action device key value in the protocol message are equal.

14.2.4 ActionQueueSize

Name	ActionQueueSize
Category	ActionControl
Level	Optional
Interface	IInteger
Access	Read
Unit	-
Visibility	Guru
Values	≥ 0

Indicates the size of the scheduled action commands queue. This number represents the maximum number of scheduled action commands that can be pending at a given point in time.

14.2.5 ActionSelector

Name	ActionSelector
Category	ActionControl
Level	Optional
Interface	IInteger
Access	Read/Write
Unit	-
Visibility	Guru
Values	≥ 0

Selects to which Action Signal further Action settings apply.

14.2.6 ActionGroupMask

Name	ActionGroupMask[ActionSelector]
Category	ActionControl
Level	Optional
Interface	IInteger
Access	Read/Write
Unit	-
Visibility	Guru
Values	≥ 0

Provides the mask that the device will use to validate the action on reception of the action protocol message.

The device asserts the selected Action signal only if:

- The selected **ActionDeviceKey** is equal to the action device key in the action protocol message.
- The logical AND-wise operation of the action group mask in the action protocol message against the selected **ActionGroupMask** is non-zero.
- The selected **ActionGroupKey** is equal to the action group key in the action protocol message.

15 Event Control

This chapter describes how to control the generation of Events to the host application. An Event is a message that is sent to the host application to notify it of the occurrence of an internal event.

Events are typically used to synchronize the host application with some Events happening in the device. A typical use in machine vision is a host application that waits to be notified of the sensor's exposure end to move the inspected part on a conveyor belt.

EventSelector selects which particular Event to control. There are many sources of events such as Acquisition, Timer, Counter and I/O lines.

The standard Acquisition related Events are: **AcquisitionTrigger**, **AcquisitionStart**, **AcquisitionEnd**, **AcquisitionTransferStart**, **AcquisitionTransferEnd**, **AcquisitionError**, **FrameTrigger**, **FrameStart**, **FrameEnd**, **FrameBurstStart**, **FrameBurstEnd**, **FrameTransferStart**, **FrameTransferEnd**, **ExposureStart**, **ExposureEnd** (Figure 5-1 to Figure 5-15).

The standard Counters and Timers related Events are: **Counter0Start**, **Counter0End**, **Counter1Start**, **Counter1End**, ... **Timer0Start**, **Timer0End**, **Timer1Start**, **Timer1End**, ...

The standard I/O line Events are: **Line0RisingEdge** , **Line0FallingEdge**, **Line0AnyEdge**, **Line1RisingEdge**, **Line1FallingEdge**, ... Note that the event signal is monitored at the same place as **LineStatus** in the I/O control block (See Figure 9-1). This means that event is checked against the condition after the input inverter.

EventNotification is used to enable or disable the notification of the occurrence of the internal event selected by **EventSelector**. If **EventNotification** is **Off**, no event of the selected type is generated.

For each of the events listed in the **EventSelector** enumeration, there must be a corresponding feature with a standard name (ex: **EventExposureEnd**). The controlling application can rely on this event identifier to register a callback function to be notified that the event happened.

Also for each Event, there should be, in the **EventControl** category, a sub category grouping all the data members related to the particular event (Ex: **EventExposureEndData**).

The other data members in that category should also follow the naming convention described below (Ex: **EventExposureEndTimestamp**).

The recommended optional data members are:

- Timestamp: Unique timestamp of the Event.
- FrameID: Unique ID of the Frame (or image) that generated the Event (if applicable).
- Followed by any other data related to this particular event.

Therefore, the naming convention for the Event related features is:

For each Event (Ex: **ExposureEnd**):

- You should provide, in the **EventControl** category, an ICategory named:
Event prefix + "**EventName**" + **Data** postfix (Ex: **EventExposureEndData**)
- You must provide an IInteger Event feature that will be used as a unique identifier of the event to register the callback and that is named:
Event prefix + "**EventName**" (Ex: **EventExposureEnd**).
- You should provide for each optional data member a corresponding feature named:
Event prefix + "**EventName**" + "**DataMember**" (Ex: **EventExposureEndTimestamp**).

For the **ExposureEnd** event that would be member of **EventSelector**, this would give:

ICategory **EventExposureEndData**

IInteger **EventExposureEnd**

IInteger **EventExposureEndTimeStamp**

IInteger **EventExposureEndFrameID**

...

With the above naming convention, for each Event listed in **EventSelector**:

- A user always knows the name of the Feature to use to register a call back on that Event.
- The user can take the parent of this feature to find the corresponding Event category.
- In this Event category, the user will find all the features related to this Event.

For example, to do a continuous acquisition and be notified at the end of the exposure period of each frame to move the part and also get the timestamp, the following pseudo-code can be used:

```
Register(Camera.EventExposureEnd, CallbackDataObject, CallbackFunctionPtr)

Camera.EventSelector      = ExposureEnd;
Camera.EventNotification = On;

Camera.AcquisitionMode   = Continuous;
Camera.AcquisitionStart();

...

// In the callback of the ExposureEnd event, gets the event timestamp:
Timestamp = Camera.EventExposureEndTimestamp;

...

Camera.AcquisitionStop();
```

Here below, in addition to **EventControl**, **EventSelector** and **EventNotification** should be listed all the categories and data related features for each Event listed in the **EventSelector** enumeration feature.

For simplicity, all the categories and their data members are not listed explicitly in that document but a precise naming convention for the categories and their member is provided above instead.

Below, the detailed features for the members of the **EventSelector** are only listed for 4 typically recommended events: **FrameTrigger**, **ExposureEnd**, **Error** and **EventTest**.

All the other members of the **EventSelector** feature should follow the exact same pattern for their features naming and category if they are present in a device.

15.1 EventControl

Name	EventControl
Category	Root
Level	Recommended
Interface	ICategory
Access	Read
Unit	-
Visibility	Expert
Values	-

Category that contains Event control features.

15.2 EventSelector

Name	EventSelector
Category	EventControl
Level	Recommended
Interface	IEnumeration
Access	Read/Write
Unit	-
Visibility	Expert

Values	
	AcquisitionTrigger
	AcquisitionTriggerMissed
	AcquisitionStart
	AcquisitionEnd
	AcquisitionTransferStart
	AcquisitionTransferEnd
	AcquisitionError
	FrameBurstStart
	FrameBurstEnd
	FrameTrigger
	FrameTriggerMissed
	FrameStart
	FrameEnd
	FrameTransferStart
	FrameTransferEnd
	LineTrigger
	LineTriggerMissed
	LineStart
	LineEnd
	ExposureStart
	ExposureEnd
	Stream0TransferStart
	Stream0TransferEnd
	Stream0TransferPause
	Stream0TransferResume
	Stream0TransferBlockStart
	Stream0TransferBlockEnd
	Stream0TransferBlockTrigger
	Stream0TransferBurstStart
	Stream0TransferBurstEnd
	Stream0TransferOverflow
	SequencerSetChange
	Counter0Start (If 0 based), Counter1Start, ...
	Counter0End (If 0 based), Counter1End, ...
	Timer0Start (If 0 based), Timer1Start, ...
	Timer0End (If 0 based), Timer1End, ...
	Encoder0Stopped (If 0 based),
	Encoder1 Stopped, ...
	Encoder0Restarted (If 0 based),
	Encoder1 Restarted, ...
	Line0RisingEdge (If 0 based),
	Line1 RisingEdge, ...
	Line0FallingEdge (If 0 based),
	Line1 FallingEdge, ...
	Line0AnyEdge (If 0 based),

	<p>Line1AnyEdge, ... LinkTrigger0 (If 0 based), LinkTrigger1, ... LinkSpeedChange ActionLate Error Test</p> <p>Device-specific</p> <p>- GigE Vision Specific: PrimaryApplicationSwitch</p>
--	--

Selects which Event to signal to the host application.

See Figure 5-1 to Figure 5-4 and Figure 19-1 for details..

Possible values are:

- **AcquisitionTrigger:** Device just received a trigger for the Acquisition of one or many Frames.
- **AcquisitionTriggerMissed:** Device just missed a trigger for the Acquisition of one or many Frames.
- **AcquisitionStart:** Device just started the Acquisition of one or many Frames.
- **AcquisitionEnd:** Device just completed the Acquisition of one or many Frames.
- **AcquisitionTransferStart:** Device just started the transfer of one or many Frames.
- **AcquisitionTransferEnd:** Device just completed the transfer of one or many Frames.
- **AcquisitionError:** Device just detected an error during the active Acquisition.
- **FrameBurstStart:** Device just started the capture of a burst of Frames.
- **FrameBurstEnd:** Device just completed the capture of a burst of Frames.
- **FrameTrigger:** Device just received a trigger to start the capture of one Frame.
- **FrameTriggerMissed:** Device just missed a trigger to start the capture of one Frame.
- **FrameStart:** Device just started the capture of one Frame.
- **FrameEnd:** Device just completed the capture of one Frame.
- **FrameTransferStart:** Device just started the transfer of one Frame.
- **FrameTransferEnd:** Device just completed the transfer of one Frame.
- **LineTrigger:** Device just received a trigger to start the capture of one Line.
- **LineTriggerMissed:** Device just missed a trigger to start the capture of one Line.
- **LineStart:** Device just started the capture of one Line.
- **LineEnd:** Device just completed the capture of one Line.

- **ExposureStart**: Device just started the exposure of one Frame (or Line).
- **ExposureEnd**: Device just completed the exposure of one Frame (or Line).
- **Stream0TransferStart**: Device just started the transfer of one or many Blocks.
- **Stream0TransferEnd**: Device just completed the transfer of one or many Blocks.
- **Stream0TransferPause**: Device just paused the transfer.
- **Stream0TransferResume**: Device just resumed the transfer.
- **Stream0TransferBlockStart**: Device just started the transfer of one Block.
- **Stream0TransferBlockEnd**: Device just completed the transfer of one Block.
- **Stream0TransferBlockTrigger**: Device just received a trigger to start the transfer of one Block.
- **Stream0TransferBurstStart**: Device just started the transfer of a burst of Blocks.
- **Stream0TransferBurstEnd**: Device just completed the transfer of a burst of Blocks.
- **Stream0TransferOverflow**: Device transfer queue overflowed.
- **SequencerSetChange**: Device sequencer set has changed.
- **Counter0Start**: The event will be generated when counter 0 starts counting.
- **Counter0End**: The event will be generated when counter 0 ends counting.
- **Counter1Start**: The event will be generated when counter 1 starts counting.
- **Counter1End**: The event will be generated when counter 1 ends counting.
- **Timer0Start**: The event will be generated when Timer 0 starts counting.
- **Timer0End**: The event will be generated when Timer 0 ends counting.
- **Timer1Start**: The event will be generated when Timer 1 starts counting.
- **Timer1End**: The event will be generated when Timer 1 ends counting.
- **Encoder0Stopped**: The event will be generated when the Encoder 0 stops for longer than EncoderTimeout.
- **Encoder1Stopped**: The event will be generated when the Encoder 1 stops for longer than EncoderTimeout.
- **Encoder0Restarted**: The event will be generated when the Encoder 0 restarts moving.
- **Encoder1Restarted**: The event will be generated when the Encoder 1 restarts moving.
- **Line0RisingEdge**: The event will be generated when a Rising Edge is detected on the Line 0.
- **Line1RisingEdge**: The event will be generated when a Rising Edge is detected on the Line 1.
- **Line0FallingEdge**: The event will be generated when a Falling Edge is detected on the Line 0.
- **Line1FallingEdge**: The event will be generated when a Falling Edge is detected on the Line 1.

- **Line0AnyEdge:** The event will be generated when a Falling or Rising Edge is detected on the Line 0.
- **Line1AnyEdge:** The event will be generated when a Falling or Rising Edge is detected on the Line 1.
- **LinkTrigger0RisingEdge:** The event will be generated when a Rising Edge is detected on the LinkTrigger 0.
- **LinkTrigger1RisingEdge:** The event will be generated when a Rising Edge is detected on the LinkTrigger 1.
- **LinkTrigger0FallingEdge:** The event will be generated when a Falling Edge is detected on the LinkTrigger 0.
- **LinkTrigger1FallingEdge:** The event will be generated when a Falling Edge is detected on the LinkTrigger 1.
- **LinkTrigger0AnyEdge:** The event will be generated when a Falling or Rising Edge is detected on the LinkTrigger 0
- **LinkTrigger1AnyEdge:** The event will be generated when a Falling or Rising Edge is detected on the LinkTrigger 1.
- **LinkSpeedChange:** The event will be generated when the link speed has changed.
- **ActionLate:** The event will be generated when a valid scheduled action command is received and is scheduled to be executed at a time that is already past.
- **Error:** The event will be generated when the device encounter an error.
- **Test:** The test event will be generated when the device receives the TestEventGenerate command (EventNotification for the Test event is always On).
- **PrimaryApplicationSwitch:** The event will be generated when a primary application switchover has been granted (GigE Vision Specific).

15.3 EventNotification

Name	EventNotification[EventSelector]
Category	EventControl
Level	Recommended
Interface	IEnumeration
Access	Read/Write
Unit	-
Visibility	Expert
Values	Off On Once

Activate or deactivate the notification to the host application of the occurrence of the selected Event.

Possible values are:

- **Off:** The selected Event notification is disabled.
- **On:** The selected Event notification is enabled.
- **Once:** The selected Event notification is enabled for one event then return to Off state.

15.4 Frame Trigger Event (Example #1)

Below are the recommended features for the Frame Trigger Event handling.

15.4.1 EventFrameTriggerData

Name	EventFrameTriggerData
Category	EventControl
Level	Recommended
Interface	ICategory
Access	Read
Unit	-
Visibility	Expert
Values	-

Category that contains all the data features related to the FrameTrigger Event.

15.4.2 EventFrameTrigger

Name	EventFrameTrigger
Category	EventFrameTriggerData
Level	Recommended
Interface	IInteger
Access	Read
Unit	-
Visibility	Expert
Values	-

Returns the unique Identifier of the FrameTrigger type of Event. It can be used to register a callback function to be notified of the event occurrence. Its value uniquely identifies the type event received.

15.4.3 EventFrameTriggerTimestamp

Name	EventFrameTriggerTimestamp
Category	EventFrameTriggerData
Level	Recommended
Interface	IInteger
Access	Read
Unit	-
Visibility	Expert
Values	-

Returns the Timestamp of the FrameTrigger Event. It can be used to determine precisely when the event occurred.

15.4.4 EventFrameTriggerFrameID

Name	EventFrameTriggerFrameID
Category	EventFrameTriggerData
Level	Recommended
Interface	IInteger
Access	Read
Unit	-
Visibility	Expert
Values	-

Returns the unique Identifier of the Frame (or image) that generated the FrameTrigger Event.

15.5 Exposure End Event (Example #2)

Below are the recommended features for the Exposure End Event handling.

15.5.1 EventExposureEndData

Name	EventExposureEndData
Category	EventControl
Level	Recommended
Interface	ICategory
Access	Read
Unit	-
Visibility	Expert
Values	-

Category that contains all the data features related to the ExposureEnd Event.

15.5.2 EventExposureEnd

Name	EventExposureEnd
Category	EventExposureEndData
Level	Recommended
Interface	IInteger
Access	Read
Unit	-
Visibility	Expert
Values	-

Returns the unique identifier of the ExposureEnd type of Event. This feature can be used to register a callback function to be notified of the event occurrence. Its value uniquely identifies the type of event that will be received.

15.5.3 EventExposureEndTimestamp

Name	EventExposureEndTimestamp
Category	EventExposureEndData
Level	Recommended
Interface	IInteger
Access	Read
Unit	-

Visibility	Expert
Values	-

Returns the Timestamp of the ExposureEnd Event. It can be used to determine precisely when the event occurred.

15.5.4 EventExposureEndFrameID

Name	EventExposureEndFrameID
Category	EventExposureEndData
Level	Recommended
Interface	IInteger
Access	Read
Unit	-
Visibility	Expert
Values	-

Returns the unique Identifier of the Frame (or image) that generated the ExposureEnd Event.

15.6 Error Event (Example #3)

Below are the recommended features for the Error Event handling.

15.6.1 EventErrorData

Name	EventErrorData
Category	EventControl
Level	Recommended
Interface	ICategory
Access	Read
Unit	-
Visibility	Expert
Values	-

Category that contains all the data features related to the Error Event.

15.6.2 EventError

Name	EventError
Category	EventErrorData
Level	Recommended
Interface	IInteger
Access	Read
Unit	-
Visibility	Expert
Values	-

Returns the unique identifier of the Error type of Event. It can be used to register a callback function to be notified of the Error event occurrence. Its value uniquely identifies that the event received was an Error.

15.6.3 EventErrorTimestamp

Name	EventErrorTimestamp
Category	EventErrorData
Level	Recommended
Interface	IInteger
Access	Read
Unit	-
Visibility	Expert
Values	-

Returns the Timestamp of the Error Event. It can be used to determine when the event occurred.

15.6.4 EventErrorFrameID

Name	EventErrorFrameID
Category	EventErrorData
Level	Recommended
Interface	IInteger
Access	Read
Unit	-

Visibility	Expert
Values	-

If applicable, returns the unique Identifier of the Frame (or image) that generated the Error Event.

15.6.5 EventErrorCode

Name	EventErrorCode
Category	EventErrorData
Level	Recommended
Interface	IInteger
Access	Read
Unit	-
Visibility	Expert
Values	-

Returns an error code for the error(s) that happened.

15.7 Event Test (Example #4)

Below are the recommended features for the Event Test handling.

15.7.1 EventTestData

Name	EventTestData
Category	EventControl
Level	Recommended
Interface	ICategory
Access	Read
Unit	-
99Visibility	Expert
Values	-

Category that contains all the data features related to the Event Test generated using the **TestEventGenerate** command.

15.7.2 EventTest

Name	EventTest
Category	EventTestData
Level	Recommended
Interface	IInteger
Access	Read
Unit	-
Visibility	Expert
Values	-

Returns the unique identifier of the Event Test type of event generated using the **TestEventGenerate** command. It can be used to register a callback function to be notified of the EventTest event occurrence. Its value uniquely identifies that the event received was an Event Test.

15.7.3 EventTestTimestamp

Name	EventTestTimestamp
Category	EventTestData
Level	Recommended
Interface	IInteger
Access	Read
Unit	-
Visibility	Expert
Values	-

Returns the Timestamp of the Event Test event. It can be used to determine when the event occurred.

16 User Set Control

This chapter describes the features for global control of the device settings. It allows loading or saving factory or user-defined settings.

Loading the factory default User Set guarantees a state where a continuous acquisition can be started using only the mandatory features.

16.1 UserSetControl

Name	UserSetControl
Category	Root
Level	Recommended
Interface	ICategory
Access	Read
Unit	-
Visibility	Beginner
Values	-

Category that contains the User Set control features.

16.2 UserSetSelector

Name	UserSetSelector
Category	UserSetControl
Level	Recommended
Interface	IEnumeration
Access	Read/Write
Unit	-
Visibility	Beginner
Values	Default UserSet0 (if 0 based), UserSet1, ...

Selects the feature User Set to load, save or configure.

Possible values are:

- **Default:** Selects the factory setting user set.

- **UserSet0**: Selects the user set 0.
- **UserSet1**: Selects the user set 1.
- ...

When **Default** User Set is selected and loaded using **UserSetLoad**, the device must be in default factory settings state and must make sure the continuous acquisition use case works directly. Default User Set is read-only and cannot be modified.

16.3 UserSetLoad

Name	UserSetLoad[UserSetSelector]
Category	UserSetControl
Level	Recommended
Interface	ICommand
Access	(Read)/Write
Unit	-
Visibility	Beginner
Values	-

Loads the User Set specified by **UserSetSelector** to the device and makes it active.

16.4 UserSetSave

Name	UserSetSave[UserSetSelector]
Category	UserSetControl
Level	Recommended
Interface	ICommand
Access	(Read)/Write
Unit	-
Visibility	Beginner
Values	-

Save the User Set specified by **UserSetSelector** to the non-volatile memory of the device.

16.5 UserSetDefault

Name	UserSetDefault
Category	UserSetControl

Level	Optional
Interface	IEnumeration
Access	Read/Write
Unit	-
Visibility	Beginner
Values	Default UserSet0 (if 0 based), UserSet1, ...

Selects the feature User Set to load and make active by default when the device is reset.

Possible values are:

- **Default:** Select the factory setting user set.
- **UserSet0:** Select the user set 0.
- **UserSet1:** Select the user set 1.
- ...

If **Default** is selected, the device will boot with the default factory settings and makes sure the continuous acquisition use case is ready to be used.

16.6 UserSetDefaultSelector (Deprecated)

Name	UserSetDefaultSelector
Category	UserSetControl
Level	Optional
Interface	IEnumeration
Access	Read/Write
Unit	-
Visibility	Invisible
Values	Default UserSet0 (if 0 based), UserSet1, ...

This feature is deprecated (See **UserSetDefault**). Selects the feature User Set to load and make active when the device is reset.

To help backward compatibility, this feature can be included as Invisible in the device's XML.

Possible values are:

- **Default:** Select the factory setting user set.
- **UserSet0:** Select the user set 0.
- **UserSet1:** Select the user set 1.
- ...

If **Default** is selected, the device will boot with the default factory settings and makes sure the continuous acquisition use case works directly.

16.7 UserSetFeatureSelector

Name	UserSetFeatureSelector
Category	UserSetControl
Level	Recommended
Interface	IEnumeration
Access	Read/Write
Unit	-
Visibility	Expert
Values	Device-Specific

Selects which individual UserSet feature to control.

The feature lists all the features that can be a part of a device UserSet. All the device's UserSets have the same features.

Note that the name used in the enumeration must match exactly the device's feature name. If the target feature is under a selector, the name of the enumeration in the selector can be appended to the feature name to precisely target an individual element.

16.8 UserSetFeatureEnable

Name	UserSetFeatureEnable[UserSet FeatureSelector]
Category	UserSetControl
Level	Recommended
Interface	IBoolean
Access	Read/(Write)
Unit	-
Visibility	Expert
Values	True

False

Enables the selected feature and make it active in all the UserSets.

17 Sequencer Control

The Sequencer Control chapter describes the model and features related to the control of the sequencers that can be used to change some features of the device automatically based on different events and signals.

17.1 Sequencer control model

The Sequencer Control Model section describes the usage of the features related to the sequencing of automatic changes to features by the device. It describes the basic Sequencer model and the typical behavior of the device when a sequencer is used.

Sequencer overview

The purpose of a sequencer is to allow the user of a camera to define a series of feature sets for image acquisition which can consecutively be activated during the acquisition by the camera. Accordingly, the proposed sequence is configured by a list of parameter sets.

Each of these sequencer sets contains the settings for a number of camera features. Similar to user sets, the actual settings of the camera are overwritten when one of these sequencer sets is loaded. The order in which the features are applied to the camera depends on the design of the vendor. It is recommended to apply all the image related settings to the camera, before the first frame of this sequence is captured.

The sequencer sets can be loaded and saved by selecting them using **SequencerSetSelector**. The Execution of the sequencer is completely controlled by the device.

Configuration of a sequencer set

The index of the adjustable sequencer set is given by the **SequencerSetSelector**. The number of available sequencer sets is directly given by the range of this feature.

The features which are actually part of a sequencer set are defined by the camera manufacturer. These features can be read by **SequencerFeatureSelector** and activated by **SequencerFeatureEnable[SequencerFeatureSelector]**. This configuration is the same for all Sequencer Sets.

To configure a sequencer set the camera has to be switched into configuration mode by **SequencerConfigurationMode**. Then the user has to select the desired sequencer set he wants to modify with the **SequencerSetSelector**. After the user has changed all the needed camera settings it is possible to store all these settings within a selected sequencer set by **SequencerSetSave[SequencerSetSelector]**. The user can also read back this settings by **SequencerSetLoad[SequencerSetSelector]**.

To permit a flexible usage, more than one possibility to go from one sequencer set to another can exist. Such a path is selected by **SequencerPathSelector[SequencerSetSelector]**. Each path and therefore the transition between different sequencer sets is based on a defined trigger and an aimed next sequencer set which is selectable by **SequencerSetNext[SequencerSetSelector][SequencerPathSelector]**. After the trigger occurs the settings of the next set are active.

The trigger is defined by the features

SequencerTriggerSource[SequencerSetSelector][SequencerPathSelector] and **SequencerTriggerActivation[SequencerSetSelector][SequencerPathSelector]**. The functions of these features are the same as **TriggerSource** and **TriggerActivation**. For a flexible sequencer implementation, the **SequencerPathSelector[SequencerSetSelector]** should be part of the sequencer sets.

A sequencer set should contain the following values:

- Camera data which should be controlled by the device
- **SequencerPathSelector[SequencerSetSelector]** with at least one path
- **SequencerSetNext**, **SequencerTriggerSource** and **SequencerTriggerActivation** for every path which is selectable by the **SequencerPathSelector**.

An example of a sequencer set is shown in the following figure:

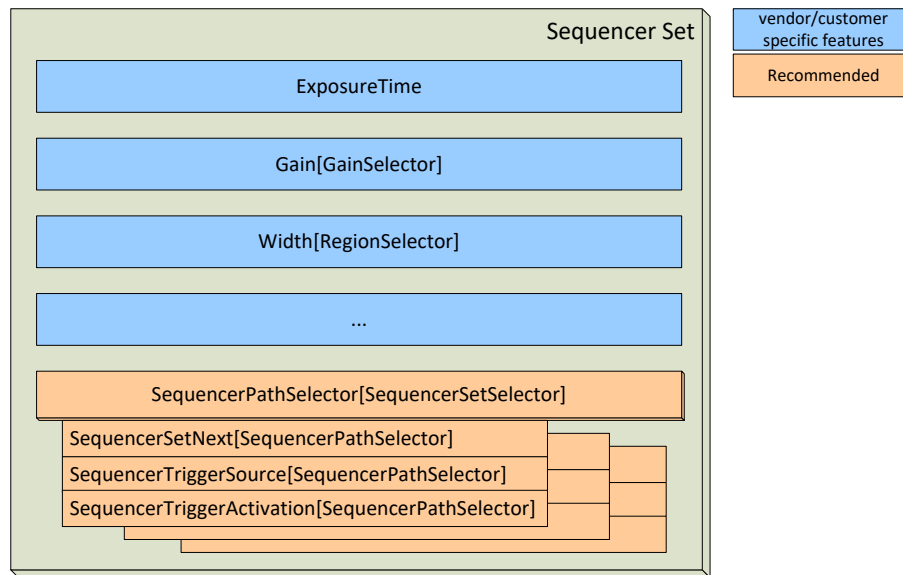

Operation of a sequencer

The sequencer is started or stopped using the feature **SequencerMode**. If the sequencer is switched on, the start set which is defined by **SequencerSetStart** is loaded. The **SequencerStartSet** can take the same values as **SequencerSetSelector**.

While the sequencer is running, the **SequencerSetActive** is updated each time a new set is loaded. The feature can be used to read the current set – and the user might monitor the sequencer triggers.

If a trigger, which is selected by **SequencerTriggerSource[SequencerSetSelector][SequencerPathSelector]** and **SequencerTriggerActivation[SequencerSetSelector][SequencerPathSelector]** occurs, the sequencer switches to the next set. This set is configured by **SequencerSetNext[SequencerSetSelector][SequencerPathSelector]**, which is also part of a special sequencer path. If there is more than one path selected, the sequencer switches to the set whose trigger primarily occurred.

The matching between sequencer sets and currently taken frames can be realized with chunk mode or events.

17.2 Sequencer usage examples

Example 1: Simple features change while acquiring images

In this example, Set 0 and Set 1 are the main sets for the device (here a camera) to capture images. The only parameters within the sequencer sets are **Exposure Time, Gain, Width** and the (recommended) **SequencerPathSelector** and therefore **SequencerSetNext, SequencerTriggerSource**.

Set 0 is like a free running mode. After every image capture the camera stays in set 0. If a change on Line0 occurs, the sequencer switches to set 1 but only for 1 image capture. The parameters of the singles sets are the following:

- Set 0:
 - ExposureTime = 4000
 - Gain = 1.0
 - Width = 1024
 - SequencerSetNext[0] = 0
 - SequencerTriggerSource[0] = ExposureEnd
 - SequencerSetNext[1] = 1
 - SequencerTriggerSource[1] = Line0
- Set 1:
 - ExposureTime = 2000
 - Gain = 2.0
 - Width = 512
 - SequencerSetNext[0] = 0
 - SequencerTriggerSource[0] = ExposureEnd

The working diagram is shown in the following figure:

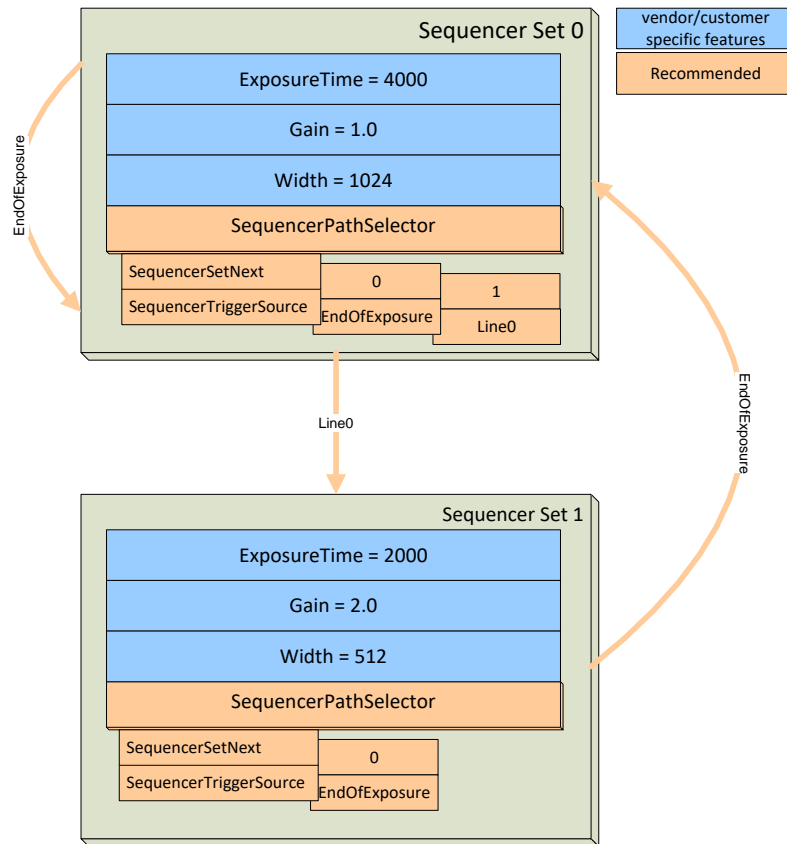

Example 2: Complex changes to features with multiples selectors.

In this example, the camera has 4 configurable sets. Set 0 and Set 1 are the main sets for the device to capture images. The only parameters within the sequencer sets are **Exposure Time**, **Gain** and the **SequencerPathSelector** and therefore **SequencerSetNext**, **SequencerTriggerSource**.

After the camera has captured an image with Set 0 the sequencer switches to Set 1. Then after the camera has captured another image with Set 1, the sequencer switches back to Set 0. So the most time the sequencer is alternating between Set 0 and Set 1. But 2 timers with different run times are also used to activate Set 2 and Set 3 when required.

The parameters of the individual sets are:

- **Set 0:**
 - ExposureTime = 4000
 - Gain = 1.0
 - SequencerSetNext[0] = 1
 - SequencerTriggerSource[0] = ExposureEnd
 - SequencerSetNext[1] = 3
- SequencerTriggerSource[1] = Timer0End

Set 1:

- ExposureTime = 2000

- Gain = 2.0
- SequencerSetNext[0] = 0
- SequencerTriggerSource[0] = ExposureEnd

Set 2:

- ExposureTime = 32000
- Gain = 1.0
- SequencerSetNext[0] = 0
- SequencerTriggerSource[0] = ExposureEnd

Set 3:

- ExposureTime = 16000
- Gain = 2.0
- SequencerSetNext[0] = 0
- SequencerTriggerSource[0] = Timer1End
- SequencerSetNext[1] = 2
- SequencerTriggerSource[1] = Timer0End

The working diagram is shown in the following figure:

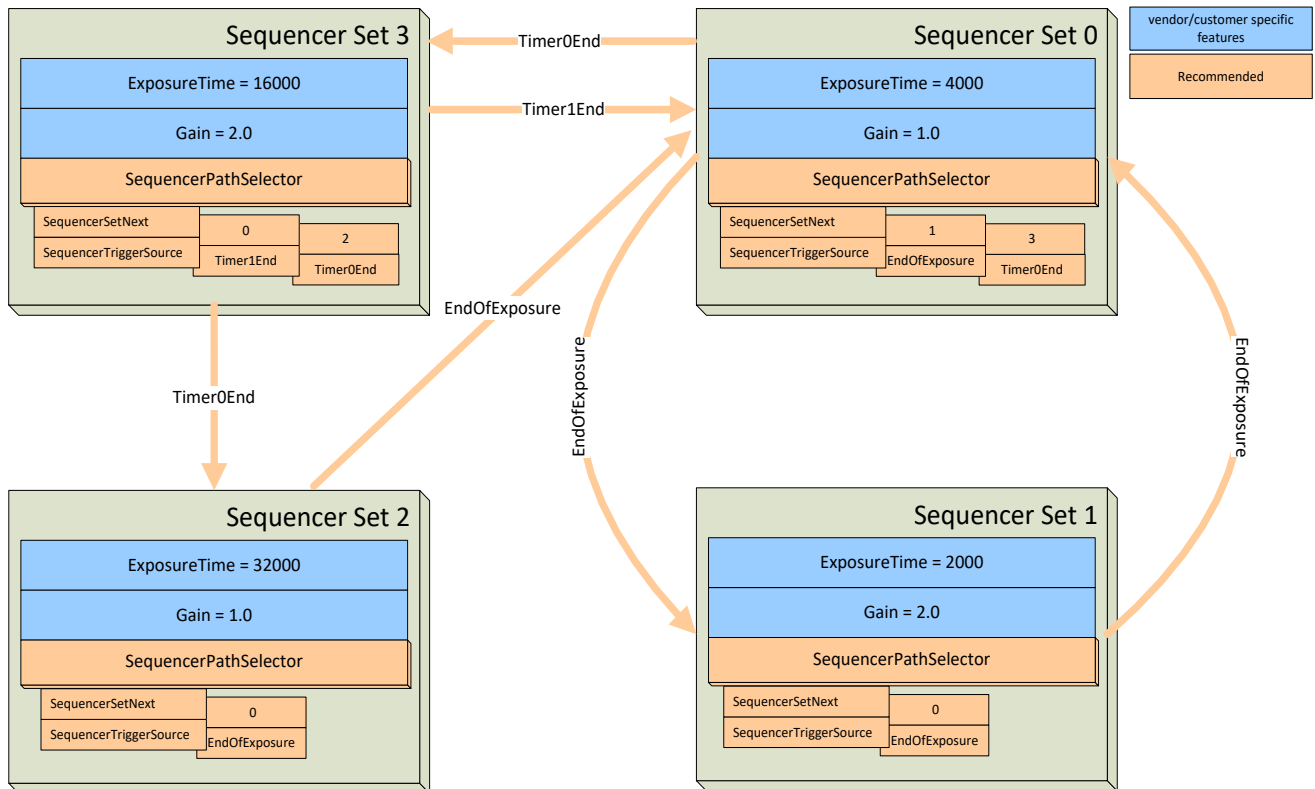

17.3 Sequencer Control features

This section describes in detail the features related to the Sequencer Control.

17.4 SequencerControl

Name	SequencerControl
Category	Root
Level	Optional
Interface	ICategory
Access	Read
Unit	-
Visibility	Expert
Values	-

Category for the Sequencer Control features.

17.5 SequencerMode

Name	SequencerMode
Category	SequencerControl
Level	Recommended
Interface	IEnumeration
Access	Read/Write
Unit	-
Visibility	Expert
Values	On Off

Controls if the sequencer mechanism is active.

Possible values are:

- **Off:** Disables the sequencer.
- **On:** Enables the sequencer.

17.6 SequencerConfigurationMode

Name	SequencerConfigurationMode
-------------	----------------------------

Category	SequencerControl
Level	Recommended
Interface	IEnumeration
Access	Read/Write
Unit	-
Visibility	Expert
Values	On Off

Controls if the sequencer configuration mode is active.

Possible values are:

- **Off:** Disables the sequencer configuration mode.
- **On:** Enables the sequencer configuration mode.

17.7 SequencerFeatureSelector

Name	SequencerFeatureSelector
Category	SequencerControl
Level	Recommended
Interface	IEnumeration
Access	Read/Write
Unit	-
Visibility	Expert
Values	Device-Specific

Selects which sequencer features to control.

The feature lists all the features that can be part of a device sequencer set. All the device's sequencer sets have the same features.

Note that the name used in the enumeration must match exactly the device's feature name.

17.8 SequencerFeatureEnable

Name	SequencerFeatureEnable[SequencerFeatureSelector]
Category	SequencerControl
Level	Recommended

Interface	IBoolean
Access	Read/(Write)
Unit	-
Visibility	Expert
Values	True False

Enables the selected feature and make it active in all the sequencer sets.

17.9 SequencerSetSelector

Name	SequencerSetSelector
Category	SequencerControl
Level	Recommended
Interface	IInteger
Access	Read/Write
Unit	-
Visibility	Expert
Values	≥ 0

Selects the sequencer set to which further feature settings applies.

17.10 SequencerSetSave

Name	SequencerSetSave[SequencerSetSelector]
Category	SequencerControl
Level	Recommended
Interface	ICommand
Access	(Read)/Write
Unit	-
Visibility	Expert
Values	-

Saves the current device state to the sequencer set selected by the **SequencerSetSelector**.

17.11 SequencerSetLoad

Name	SequencerSetLoad[SequencerSetSelector]
Category	SequencerControl
Level	Recommended
Interface	ICommand
Access	(Read)/Write
Unit	-
Visibility	Expert
Values	-

Loads the sequencer set selected by **SequencerSetSelector** in the device. Even if **SequencerMode** is off, this will change the device state to the configuration of the selected set.

17.12 SequencerSetActive

Name	SequencerSetActive
Category	SequencerControl
Level	Optional
Interface	IInteger
Access	Read
Unit	-
Visibility	Expert
Values	≥ 0

Contains the currently active sequencer set.

17.13 SequencerSetStart

Name	SequencerSetStart
Category	SequencerControl
Level	Recommended
Interface	IInteger
Access	Read/Write
Unit	-
Visibility	Expert

Values	≥ 0
---------------	----------

Sets the initial/start sequencer set, which is the first set used within a sequencer.

17.14 SequencerPathSelector

Name	SequencerPathSelector[SequencerSetSelector]
Category	SequencerControl
Level	Recommended
Interface	IInteger
Access	Read/Write
Unit	-
Visibility	Expert
Values	≥ 0

Selects to which branching path further path settings applies.

17.15 SequencerSetNext

Name	SequencerSetNext[SequencerSetSelector][SequencerPathSelector]
Category	SequencerControl
Level	Recommended
Interface	IInteger
Access	Read/Write
Unit	-
Visibility	Expert
Values	≥ 0

Specifies the next sequencer set.

17.16 SequencerTriggerSource

Name	SequencerTriggerSource[SequencerSetSelector][SequencerPathSelector]
Category	SequencerControl
Level	Recommended

Interface	IEnumeration
Access	Read/Write
Unit	-
Visibility	Expert
Values	Off AcquisitionTrigger AcquisitionTriggerMissed AcquisitionStart AcquisitionEnd FrameTrigger FrameTriggerMissed FrameStart FrameEnd FrameBurstStart FrameBurstEnd ExposureStart ExposureEnd Line0 (If 0 based), Line1, Line2, ... UserOutput0, UserOutput1, UserOutput2, ... Counter0Start (If 0 based), Counter1Start, Counter2Start, ... Counter0End (If 0 based), Counter1End, Counter2End, ... Timer0Start (If 0 based), Timer1Start, Timer2Start, ... Timer0End (If 0 based), Timer1End, Timer2End, ... Encoder0, Encoder1, Encoder2, ... LogicBlock0 (If 0 based) , LogicBlock1, LogicBlock2, ... SoftwareSignal0 (If 0 based), SoftwareSignal1, SoftwareSignal2, ... Action0 (If 0 based), Action1, Action2, ... LinkTrigger0, LinkTrigger1, LinkTrigger2, ... CC1, CC2, CC3, CC4

Specifies the internal signal or physical input line to use as the sequencer trigger source.

Possible values are:

- **Off**: Disables the sequencer trigger.
- **AcquisitionTrigger**: Starts with the reception of the Acquisition Trigger.
- **AcquisitionTriggerMissed**: Starts with the reception of the missed Acquisition Trigger.
- **AcquisitionStart**: Starts with the reception of the Acquisition Start.
- **AcquisitionEnd**: Starts with the reception of the Acquisition End.
- **FrameTrigger**: Starts with the reception of the Frame Start Trigger.

- **FrameTriggerMissed**: Starts with the reception of the missed Frame Trigger.
- **FrameStart**: Starts with the reception of the Frame Start.
- **FrameEnd**: Starts with the reception of the Frame End.
- **FrameBurstStart**: Starts with the reception of the Frame Burst Start.
- **FrameBurstEnd**: Starts with the reception of the Frame Burst End.
- **ExposureStart**: Starts with the reception of the Exposure Start.
- **ExposureEnd**: Starts with the reception of the Exposure End.
- **Line0** (If 0 based), **Line1**, **Line2**, ...: Starts when the specified TimerTriggerActivation condition is met on the chosen I/O Line.
- **UserOutput0**, **UserOutput1**, **UserOutput2**, ...: Specifies which User Output bit signal to use as internal source for the trigger.
- **Counter0Start**, **Counter1Start**, **Counter2Start**, ...: Starts with the reception of the Counter Start.
- **Counter0End**, **Counter1End**, **Counter2End**, ...: Starts with the reception of the Counter End.
- **Timer0Start**, **Timer1Start**, **Timer2Start**, ...: Starts with the reception of the Timer Start.
- **Timer0End**, **Timer1End**, **Timer2End**, ...: Starts with the reception of the Timer End.
- **Encoder0**, **Encoder1**, **Encoder2**, ...: Starts with the reception of the Encoder output signal.
- **LogicBlock0**, **LogicBlock1**, **LogicBlock2**, ...: Starts with the reception of the Logioc Block output signal.
- **SoftwareSignal0**, **SoftwareSignal1**, **SoftwareSignal2**, ...: Starts on the reception of the Software Signal.
- **Action0**, **Action1**, **Action2**, ...: Starts with the assertion of the chosen action signal.
- **LinkTrigger0**, **LinkTrigger1**, **LinkTrigger2**, ...: Starts with the reception of the chosen Link Trigger.
- **CC1**, **CC2**, **CC3**, **CC4**: Index of the Camera Link physical line and associated I/O control block to use. This ensures a direct mapping between the lines on the frame grabber and on the camera. Applicable to CameraLink products only.

17.17 SequencerTriggerActivation

Name	SequencerTriggerActivation[SequencerSetSelector][SequencerPathSelector]
Category	SequencerControl
Level	Recommended
Interface	IEnumeration
Access	Read/Write

Unit	-
Visibility	Expert
Values	RisingEdge FallingEdge AnyEdge LevelHigh LevelLow

Specifies the activation mode of the sequencer trigger.

Possible values are:

- **RisingEdge**: Specifies that the trigger is considered valid on the rising edge of the source signal.
- **FallingEdge**: Specifies that the trigger is considered valid on the falling edge of the source signal.
- **AnyEdge**: Specifies that the trigger is considered valid on the falling or rising edge of the source signal.
- **LevelHigh**: Specifies that the trigger is considered valid as long as the level of the source signal is high.
- **LevelLow**: Specifies that the trigger is considered valid as long as the level of the source signal is low.

18 File Access Control

The File Access Controls chapter describes all features related to accessing files in the device.

It contains the definition of a generic file access schema for GenICam compliant devices. It is based on a set of standard features that are controlled from adapter code which resides in the GenICam reference implementation. The adapter code presents its services through an interface inherited from `std::iostream`.

The model, on which the controls are based, is depicted in the following diagram:

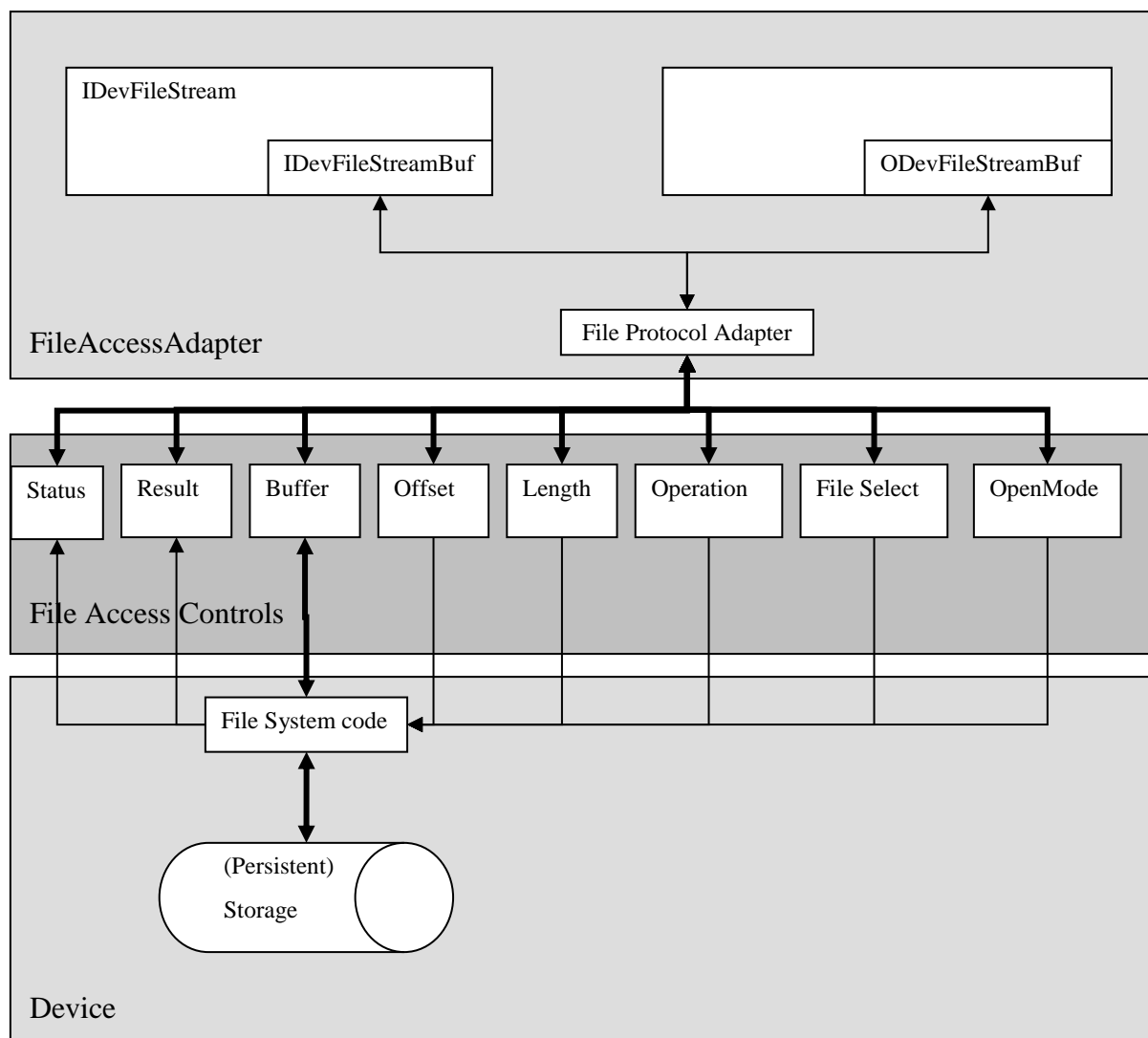

Figure 18-1: File Access Model

It assumes that all operations, which can be done on the persistent storage, could be executed by using operations with the semantic of `fopen/fclose/fread/fwrite`. The operations and their parameters are mapped onto the features of the list of File Access Controls.

To provide a generic API on top of the File Access Controls, a FileAccessAdapter is defined in the GenApi. The Adapter provides two iostream interfaces to the device files:

- **IDevFileStream** Read from the device
- **ODevFileStream** Write to the device

The File Protocol Adapter is responsible for the mapping of the (I/O) DevFileStreamBuf actions Open, Close, UnderFlow, Overflow on File Access Controls

Example Code for the streaminterface:

```
//GenApi::INodeMap * pInterface
ODevFileStream usersetWrite;
usersetWrite.open(pInterface, "UserSet1");
if( ! usersetWrite.fail() ){
    usersetWrite << "Hello World\n";
}
usersetWrite.close();

IDevFileStream usersetRead;
usersetRead.open(pInterface, "UserSet1");
if( ! usersetRead.fail() ){
    cout << usersetRead.rdbuf();
}
usersetRead.close();
```

File Access Control:

The **FileSelector** feature selects the target file in the device for the Operation. The entries of this enumeration define the names of all files in the device that can be accessed via the File Access.

FileOperationSelector specifies the operation to execute on the file.

FileOperationExecute command starts the selected operation execution.

FileOpenMode is a parameter for the Open operation and controls the access mode (Read, Write, ReadWrite) in which the file is opened.

FileOperationStatus returns the status of the last operation executed on the file. This feature must return Success if the operation is executed as requested.

FileOperationResult returns the number of bytes successfully read/written bytes during the previous Read or Write operations.

FileSize returns the size of the file in bytes.

The data, that is read from or written to the device, is exchanged between the application and the device through the **FileAccessBuffer** feature. This register mapped **FileAccessBuffer** must be written with the target data before executing the Write operation using **FileOperationExecute**. For Read operation, the data can be read from the **FileAccessBuffer** after the Read operation has been executed.

FileAccessOffset controls the starting position of the access in the file.

FileAccessLength controls the number of bytes to transfer to or from the **FileAccessBuffer** during the following Read or Write operation.

Altogether, the features **FileSelector**, **FileAccessOffset** and **FileAccessLength** control the mapping between the device file storage and the **FileAccessBuffer**.

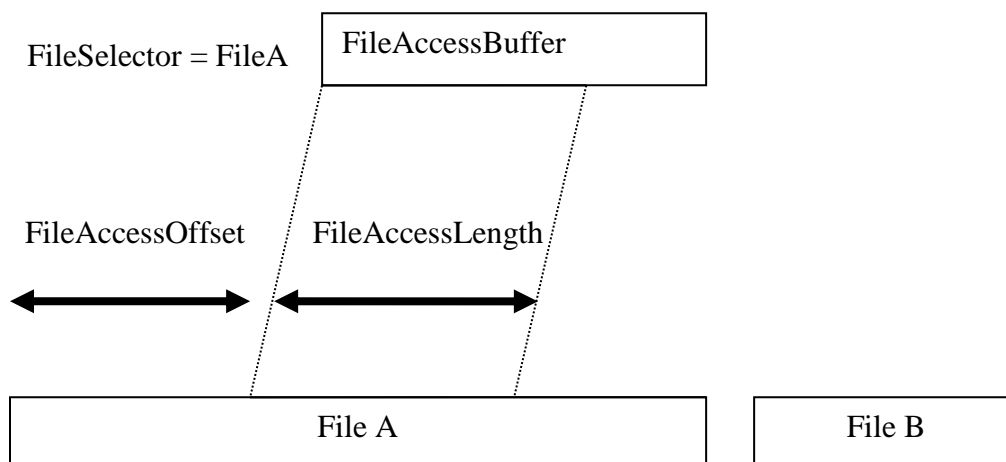

Figure 18-2: Layout of File Access Buffer.

18.1 FileAccessControl

Name	FileAccessControl
Category	Root
Level	Recommended
Interface	ICategory
Access	Read
Unit	-
Visibility	Guru
Values	-

Category that contains the File Access control features.

18.2 FileSelector

Name	FileSelector
Category	FileAccessControl
Level	Recommended
Interface	IEnumeration
Access	Read/(Write)
Unit	-
Visibility	Guru
Values	UserSetDefault UserSet1 UserSet2 UserSet3 ... LUTLuminance LUTRed LUTGreen LUTBlue ...

Selects the target file in the device.

The entries of this enumeration define the names of all files in the device that can be accessed via the File access.

Possible values are:

- **UserSetDefault:** The default user set of the device.
- **UserSet1:** The first user set of the device.
- **UserSet2:** The second user set of the device.
- **UserSet3:** The third user set of the device.
- ...
- **LUTLuminance:** The Luminance LUT of the camera.
- **LUTRed:** The Red LUT of the camera.
- **LUTGreen:** The Green LUT of the camera.
- **LUTBlue:** The Blue LUT of the camera.
- ...

On top of the previous standard values, a device might also provide device-specific values.

18.3 FileOperationSelector

Name	FileOperationSelector[FileSelector]
Category	FileAccessControl
Level	Recommended
Interface	IEnumeration
Access	Read/Write
Unit	-
Visibility	Guru
Values	Open Close Read Write Delete

Selects the target operation for the selected file in the device. This Operation is executed when the **FileOperationExecute** feature is called.

Possible values are:

- **Open:** Opens the file selected by **FileSelector** in the device. The access mode in which the file is opened is selected by **FileOpenMode**.
- **Close:** Closes the file selected by **FileSelector** in the device.
- **Read:** Reads **FileAccessLength** bytes from the device storage at the file relative offset **FileAccessOffset** into **FileAccessBuffer**.

- **Write:** Writes **FileAccessLength** bytes taken from the **FileAccessBuffer** into the device storage at the file relative offset **FileAccessOffset**.
- **Delete:** Deletes the file selected by **FileSelector** in the device. Note that deleting a device file should not remove the associated FileSelector entry to allow future operation on this file.

18.4 FileOperationExecute

Name	FileOperationExecute[FileSelector][FileOperationSelector]
Category	FileAccessControl
Level	Recommended
Interface	ICommand
Access	(Read)/Write
Unit	-
Visibility	Guru
Values	-

Executes the operation selected by **FileOperationSelector** on the selected file.

18.5 FileOpenMode

Name	FileOpenMode[FileSelector]
Category	FileAccessControl
Level	Recommended
Interface	IEnumeration
Access	Read/(Write)
Unit	-
Visibility	Guru
Values	Read Write ReadWrite

Selects the access mode in which a file is opened in the device.

Possible values are:

- **Read:** This mode selects read-only open mode.
- **Write:** This mode selects write-only open mode.
- **ReadWrite:** This mode selects read and write open mode.

18.6 FileAccessBuffer

Name	FileAccessBuffer
Category	FileAccessControl
Level	Recommended
Interface	IRegister
Access	Read/(Write)
Unit	-
Visibility	Guru
Values	Device-specific

Defines the intermediate access buffer that allows the exchange of data between the device file storage and the application.

This register mapped **FileAccessBuffer** must be written with the target data before executing a Write operation. For Read Operation, the data can be read from the **FileAccessBuffer** after the Read operation has been executed. The effective data transfer is done upon **FileOperationExecute** execution (See Figure 18-2: Layout of File Access Buffer.).

18.7 FileAccessOffset

Name	FileAccessOffset[FileSelector][FileOperationSelector]
Category	FileAccessControl
Level	Recommended
Interface	IInteger
Access	Read/(Write)
Unit	B
Visibility	Guru
Values	≥ 0

Controls the Offset of the mapping between the device file storage and the **FileAccessBuffer**.

The **FileAccessOffset** defines the offset in bytes of the **FileAccessBuffer** relative to the beginning of the selected File (See Figure 18-2). This feature is available only when **FileOperationSelector** is set to Read or Write.

18.8 FileAccessLength

Name	FileAccessLength[FileSelector][FileOperationSelector]
-------------	---

Category	FileAccessControl
Level	Recommended
Interface	IInteger
Access	Read/Write
Unit	B
Visibility	Guru
Values	≥ 0

Controls the Length of the mapping between the device file storage and the **FileAccessBuffer**.

The **FileAccessLength** defines the number of bytes to transfer to or from the **FileAccessBuffer** (See Figure 18-2). This feature is available only when **FileOperationSelector** is set to Read or Write.

18.9 FileOperationStatus

Name	FileOperationStatus[FileSelector][FileOperationSelector]
Category	FileAccessControl
Level	Recommended
Interface	IEnumeration
Access	Read
Unit	-
Visibility	Guru
Values	Success Failure ...

Represents the file operation execution status.

Upon execution of a successful file operation, it must return **Success**. In case of complete or partial failure of the operation, other return values can be defined to indicate the nature of the error that happened. If only one fail status is defined, it should be defined as **Failure**.

Possible values are:

- **Success:** File Operation was successful.
- **Failure:** File Operation failed.

18.10 FileOperationResult

Name	FileOperationResult[FileSelector][FileOperationSelector]
-------------	--

Category	FileAccessControl
Level	Recommended
Interface	IInteger
Access	Read
Unit	-
Visibility	Guru
Values	-

Represents the file operation result. For Read or Write operations, the number of successfully read/written bytes is returned.

18.11 FileSize

Name	FileSize[FileSelector]
Category	FileAccessControl
Level	Recommended
Interface	IInteger
Access	Read
Unit	B
Visibility	Guru
Values	≥ 0

Represents the size of the selected file in bytes.

19 Source Control

The Source Control chapter describes the features related to multi-source acquisition devices. An example of such a multi-source device would be a camera with 2 independent sensors (visible and infra red light) that would transmit their data on a single camera's physical connector but would have independent controllable features.

19.1 Source Control usage model with Multiple Regions and Transfers

This section explains the general model for control of the acquisition on multi-source devices.

The section also presents the relation of the sources with other elements such as the region of interest and the data transfer control module that can be found in more sophisticated multi-source devices.

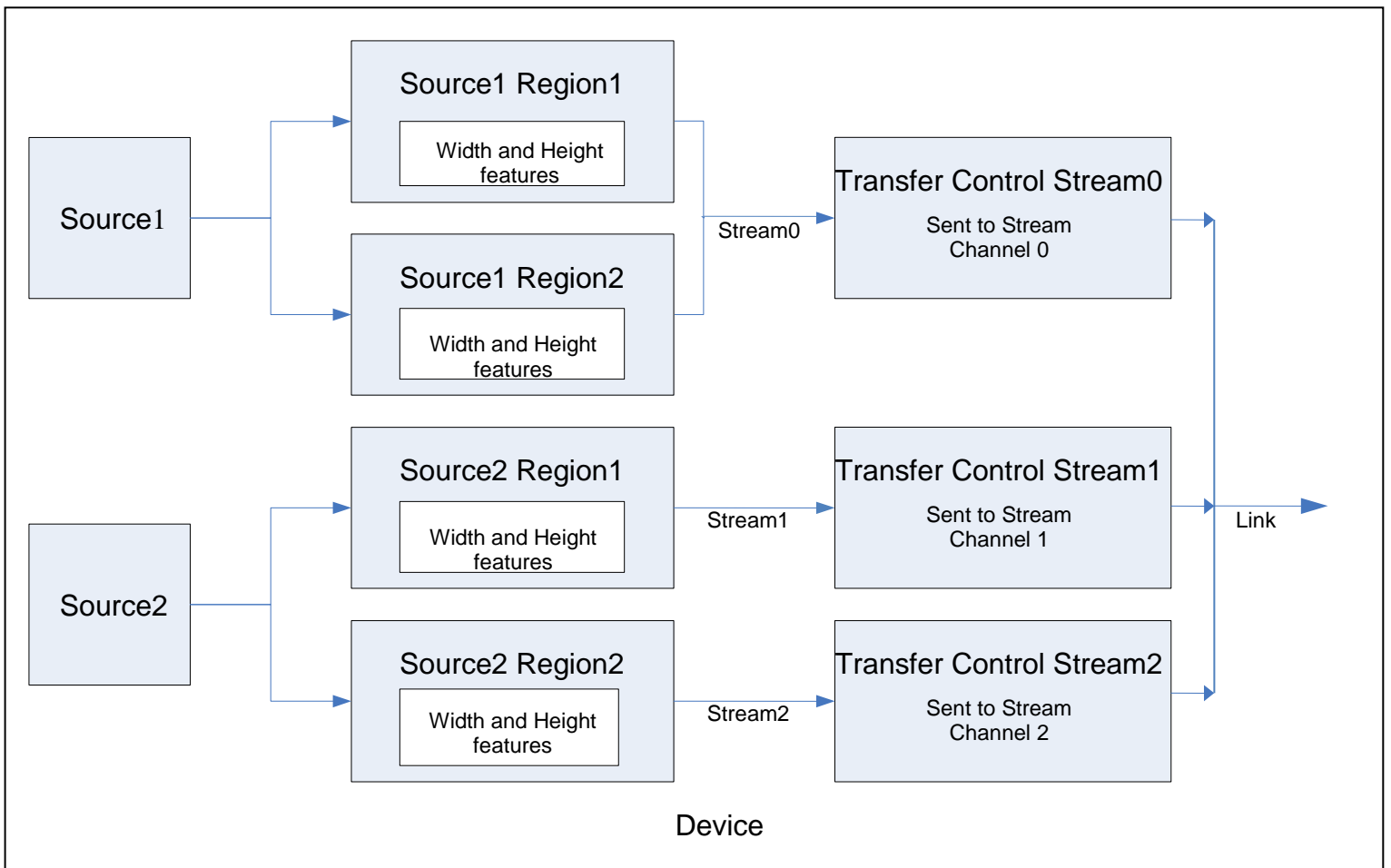

Figure 19-1: Multi-Source multi-Region Device with data stream Transfer control.

Multi-Source Features setting example

Figure 19-1 above presents an example of a relatively complex device supporting multi-source, multi-region with data stream transfer control. This device features two regions of interest for each video source. In this particular example, both regions of interest from Source1 are streamed on the same output stream channel, while a separate stream channel is used for each region of interest of Source2. The three stream channels are transmitted out of the device using the same external Link to the target Host System.

The features setting for this use case is presented below. The detailed description of the feature to control the Sources can be found in section 19.2: "Source Control features below. The features for Region of interest and image format and handling are documented in chapter 4: "Image Format Control" and chapter 20: "Transfer Control" presents the features for explicit control of data Transfer.

So for the particular use case illustrated in Figure 19-1: above, the features would be set to:

Source 1, Region 1:

```
SourceSelector = Source1
RegionSelector[SourceSelector] = Region1
RegionMode[SourceSelector][RegionSelector] = On
RegionDestination[SourceSelector][RegionSelector] = Stream0
Width[SourceSelector][RegionSelector] = 320
Height[SourceSelector][RegionSelector] = 240
```

Source 1, Region 2:

```
SourceSelector = Source1
RegionSelector[SourceSelector] = Region2
RegionMode[SourceSelector][RegionSelector] = On
RegionDestination[SourceSelector][RegionSelector] = Stream0
Width[SourceSelector][RegionSelector] = 420
Height[SourceSelector][RegionSelector] = 340
```

Source 1, Region 1 and 2, Transfer and Acquisition control:

```
TransferSelector = Stream0
TransferControlMode[TransferSelector] = UserControlled
TransferStreamChannel[TransferSelector] = 0
TransferStart[TransferSelector]
AcquisitionStart[SourceSelector]
...
AcquisitionStop[SourceSelector]
TransferStop[TransferSelector]
```

Source 2 Region 1:

```
SourceSelector = Source2
RegionSelector[SourceSelector] = Region1
RegionMode[SourceSelector][RegionSelector] = On
RegionDestination[SourceSelector][RegionSelector] = Stream1
Width[SourceSelector][RegionSelector] = 220
```

Height[SourceSelector][RegionSelector] = 140
TransferSelector = Stream1
TransferControlMode[TransferSelector] = UserControlled
TransferStreamChannel[TransferSelector] = 0

Source 2 Region 2:

SourceSelector = Source2
RegionSelector[SourceSelector] = Region2
RegionMode[SourceSelector][RegionSelector] = On
RegionDestination[SourceSelector][RegionSelector] = Stream2
Width[SourceSelector][RegionSelector] = 220
Height[SourceSelector][RegionSelector] = 330
TransferSelector = Stream2
TransferControlMode[TransferSelector] = UserControlled
TransferStreamChannel[TransferSelector] = 0

Source 1, Region 1 and 2, Transfer and Acquisition control:

TransferSelector = Stream1
TransferStart[TransferSelector]
TransferSelector = Stream2
TransferStart[TransferSelector]
SourceSelector = Source2
AcquisitionStart[SourceSelector]
...
AcquisitionStop[SourceSelector]
TransferSelector = Stream1
TransferStop[TransferSelector]
TransferSelector = Stream2
TransferStop[TransferSelector]

19.2 Source Control features

This section describes the features related to the devices that support multiple video sources that are transmitted over a single link. The virtual Stream channels of a Link are used to transport the different video sources over a common physical connection.

The main feature in this section is the source selector feature (SourceSelector). This feature enables the features associated to a given video source to be controlled on a per video source basis even if they pertain to different feature categories. For instance, it can enable a user to independently set the Width feature (Image Format Control category) and the Gain feature (Analog Control category) for the two sources supported by a given device.

An example of independent features setting for a dual source device would be:

```
SourceSelector           = Source1
Width[SourceSelector]   = 320
Gain[SourceSelector]    = 60
AcquisitionStart[SourceSelector]
...
AcquisitionStop[SourceSelector]

SourceSelector           = Source2
Width[SourceSelector]   = 240
Gain[SourceSelector]    = 90
AcquisitionStart[SourceSelector]
...
AcquisitionStop[SourceSelector]
```

Features selected by the Source Selector Feature

The source selector feature can be an optional selector to a number of features defined in this document based on the specificity of product it represents.

In order to simplify the standard text and feature descriptions, the optional source selector is not propagated to all the features of the SFNC that it can potentially select. Table 25 summarizes which features could potentially be selected by the source selector.

Table 25: Source Selector Potential Selectees

Categories	Potential Selectees
Device Control	<p>The DeviceScanType feature can potentially be selected by the source selector feature.</p> <p>Note:</p> <p>The DeviceTemperatureSelector, DeviceClockSelector and DeviceSerialPortSelector features may have more enumeration</p>

Categories	Potential Selectees
	entries.
Image Format Control Acquisition Control Analog Control LUT Control Color Transformation Control Scan 3D Control	All features of these categories could potentially be selected by the source selector based on the product specificities.
Digital I/O Control Counter and Timer Control	The features of these categories are likely not selected by the source selector but could be depending on the particular device implementation. Note: The LineSelector, LineSource, CounterEventSource, CounterResetSource, CounterTriggerSource and TimerTriggerSource features may have more enumeration entries.
Event Control	The EventSelector feature could have more enumeration entries. In this case, the name of the source would be prepended to an existing enumeration entry name. For instance, the Source1AcquisitionStart and Source2AcquisitionStart enumeration entries can be added to enable the generation of events upon acquisition start for Source1 and Source2 respectively.
GenICam Control	The TLParamsLocked feature could potentially be selected by the source selector feature.
Transport Layer Control	The ClConfiguration, ClTimeSlotsCount and DeviceTapGeometry feature could potentially be selected by the source selector feature.
User Set Control	The features of this category are likely not selected by the source selector feature.
Chunk Data Control	The ChunkSelector feature could have more enumeration entries.
File Access Control	The FileSelector feature could have more enumeration entries.
Action Control	No features can be selected by the source selector feature.

19.3 SourceControl

Name	SourceControl
Category	Root
Level	Optional
Interface	ICategory
Access	Read
Unit	-
Visibility	Beginner
Values	-

Category that contains the source control features.

19.4 SourceCount

Name	SourceCount
Category	SourceControl
Level	Optional
Interface	IInteger
Access	Read/(Write)
Unit	-
Visibility	Beginner
Values	≥ 1

Controls or returns the number of sources supported by the device.

This feature is generally read-only but can be writable if the number of sources supported by the device is run-time programmable.

19.5 SourceSelector

Name	SourceSelector
Category	SourceControl
Level	Optional
Interface	IEnumeration
Access	Read/Write
Unit	-

Visibility	Beginner
Values	Source0 (If 0 based) Source1 Source2 ... All Device-specific

Selects the source to control.

Possible values are:

- **Source0**: Selects the data source 0.
- **Source1**: Selects the data source 1.
- **Source2**: Selects the data source 2.
- ...
- **All**: Selects all the data sources.

The "All" value can be used to change the features of all the sources at the same time. For example, this can be useful to simultaneously start and stop multiple acquisitions.

19.6 SourceIDValue

Name	SourceIDValue[SourceSelector]
Category	SourceControl
Level	Optional
Interface	Integer
Access	Read
Unit	-
Visibility	Expert
Values	≥ 0

Returns a unique Identifier value that correspond to the selected Source.

This value is typically used by the Transport Layer to specify the source of the transmitted data.

20 Transfer Control

The Transfer Control chapter describes the model and features related to the explicit control of the transfer of the data acquired by a device.

A general model of the acquisition of images by a device and the role of the Transfer Control module was already presented in the section 1.6 "Device Acquisition Model" and illustrated in detail in the section 19.1 "Source Control usage model with Multiple Regions and Transfers".

So this chapter will concentrate only on describing the Transfer mechanism itself.

20.1 Transfer Control Model

The Transfer Control Model section describes the features related to the transfer of data by the device. It describes the basic Transfer model and the typical behavior of the device when sending data to the outside.

An acquisition typically generates images (or frames). Those images can be preprocessed (Ex: Bayer conversion) before transferring them out by the Device. In certain cases, those images can also be transformed in other type of data (such as an intensity histogram) by an internal image processing module. So it is possible that in addition to the original image acquired, a transformed image or some related data also needs to be transferred out of the device. In the following model, it is considered that the captured images are transformed into different data blocks by an optional image processing module. Those data blocks are then sent to a transfer module on different data streams. The Transfer module will then transmit those data blocks externally on one or many streaming channels. This typical acquisition data flow is represented here:

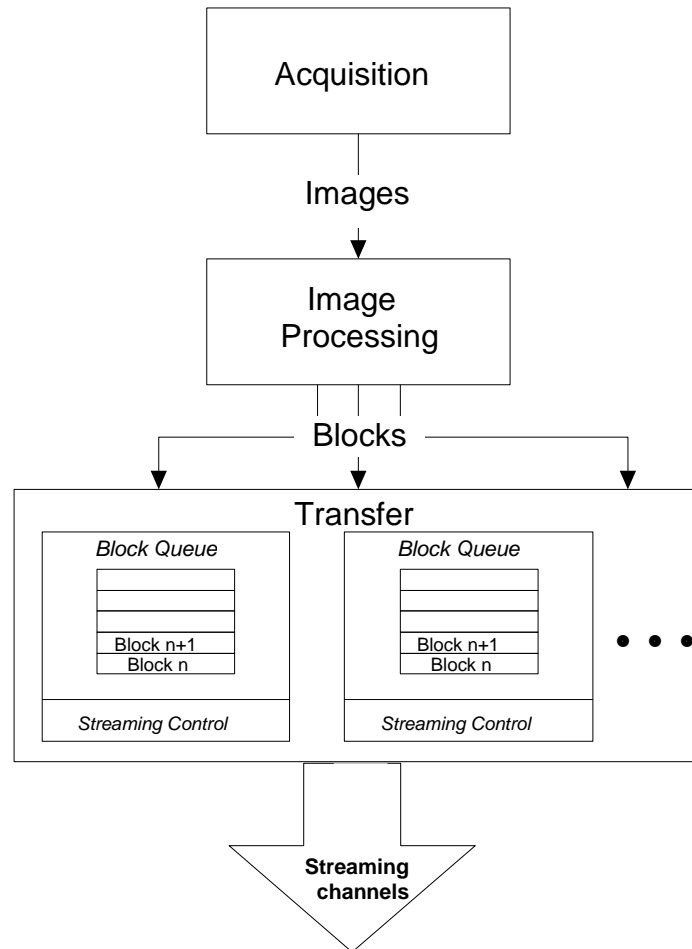

Figure 20-1: Acquisition and Transfer data flow.

In summary, a transfer is the action of streaming data blocks to another device. Data blocks are complex data structures that can represent images, image processing results or even files. The transfer module is composed of one or many block Queue(s) and Streaming Controls section(s).

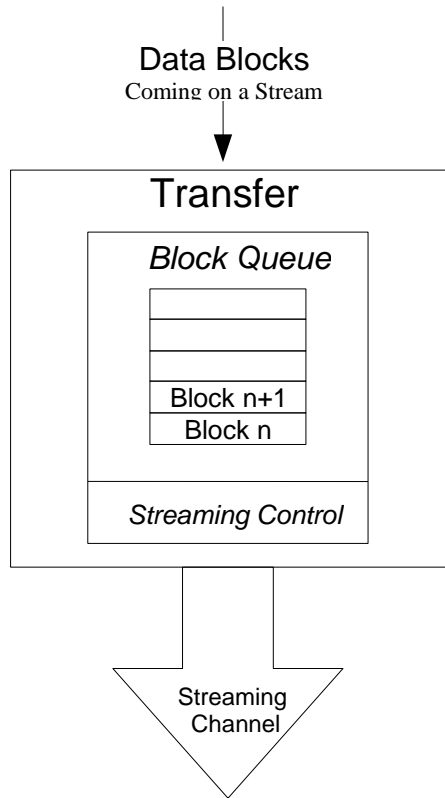

Figure 20-2: Transfer control section.

Block Queue

A Block Queue is used to store data blocks for the time interval between its generation and its transmission.

Streaming Control

The streaming control regulates the outgoing flow of data. The streaming can be in one of the following states: *Stopped*, *Stopping*, *Streaming* and *Paused*. The transfer module always accepts the new blocks of data from the image processing module regardless of the streaming state. The transfer control features **TransferStart**, **TransferStop**, **TransferAbort**, **TransferPause** and **TransferResume** allow the user to change the state of the streaming.

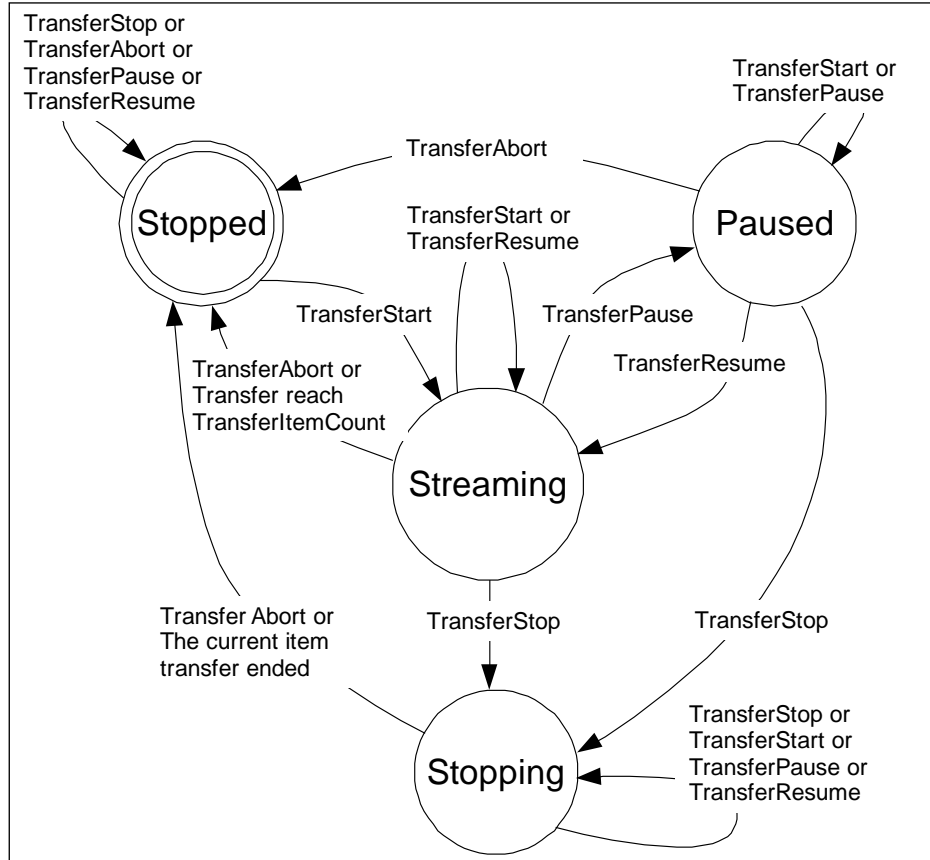

Figure 20-3: Transfer control state.

Streaming: Data blocks will be transmitted when enough data is available.

Stopping: Data blocks transmission is stopping. The current block transmission will be completed and the transfer state will change to **Stopped**.

Stopped: Data blocks transmission is stopped.

Paused: Data blocks transmission is suspended immediately.

20.2 Transfer Control features

This section describes in detail the features related to the Transfer Control.

A detailed example of the usage of the Transfer Control features is presented in the section 19.1 "Source Control usage model with Multiple Regions and Transfers".

20.3 TransferControl

Name	TransferControl
Category	Root
Level	Recommended
Interface	ICategory
Access	Read
Unit	-
Visibility	Expert
Values	-

Category for the data Transfer Control features.

20.4 TransferSelector

Name	TransferSelector
Category	TransferControl
Level	Optional
Interface	IEnumeration
Access	Read/(Write)
Unit	-
Visibility	Expert
Values	Stream0 (if 0 based), Stream1, Stream2, ... All

Selects which stream transfers are currently controlled by the selected Transfer features.

Possible values are:

- **Stream0**: The transfer features control the data stream 0.
- **Stream1**: The transfer features control the data stream 1.
- **Stream2**: The transfer features control the data stream 2.
- ...
- **All**: The transfer features control all the data streams simulateneously.

20.5 TransferControlMode

Name	TransferControlMode[TransferSelector]
Category	TransferControl
Level	Recommended
Interface	IEnumeration
Access	Read/(Write)
Unit	-
Visibility	Expert
Values	Basic Automatic UserControlled

Selects the control method for the transfers.

Possible values are:

- **Basic**: Transfer flow control mechanism is disabled. The **TransferStart**, **TransferPause**, **TransferResume**, **TransferStop** and **TransferAbort** features are not available to the user. This transfer mode is used to ensure compatibility with devices not aware of the transfer flow control mechanism.
- **Automatic**: Transfer flow control mechanism is controlled automatically. The Transfer features are controlled transparently by the acquisition features.
 - **TransferStart** is called during the AcquisitionStart.
 - **TransferStop** is never called.
 - **TransferAbort** is called during the AcquisitionAbort.
 - **TransferOperationMode** is read only and set to "Continuous".

If available, the **TransferPause** and **TransferResume** features are controlled by the user.

- **UserControlled**: Transfer flow control mechanism is controlled by the user. The **TransferMode**, **TransferStart**, **TransferStop**, **TransferAbort**, **TransferPause** and **TransferResume** features are used

to control manually the flow of data. In this mode, the features **TransferOperationMode**, **TransferStart** and **TransferStop** must be available.

If this feature is not present, the transfer control is assumed to be "Basic".

Note that the Transfers can also be controlled using external trigger signals (See **TransferTriggerSelector**).

20.6 TransferOperationMode

Name	TransferOperationMode[TransferSelector]
Category	TransferControl
Level	Optional
Interface	IEnumeration
Access	Read/(Write)
Unit	-
Visibility	Expert
Values	Continuous MultiBlock

Selects the operation mode of the transfer.

Possible values are:

- **Continuous**: Blocks of data are transferred continuously until stopped with the **TransferStop** command.
- **MultiBlock**: The transfer of the blocks of data terminates automatically after the transmission of **TransferBlockCount** or when an explicit **TransferStop** command is received.

If this feature is not present, the transfer mode is assumed to be "Continuous".

20.7 TransferBlockCount

Name	TransferBlockCount[TransferSelector]
Category	TransferControl
Level	Optional
Interface	IInteger
Access	Read/(Write)
Unit	-
Visibility	Expert
Values	> 0

Specifies the number of data Blocks that the device should stream before stopping. This feature is only active if the **TransferOperationMode** is set to MultiBlock.

20.8 TransferBurstCount

Name	TransferBurstCount
Category	TransferControl
Level	Optional
Interface	IInteger
Access	Read/Write
Unit	-
Visibility	Expert
Values	≥1

Number of Block(s) to transfer for each TransferBurstStart trigger.

This feature is used only if the TransferBurstStart trigger is enabled and the TransferBurstEnd trigger is disabled.

20.9 TransferQueueMaxBlockCount

Name	TransferQueueMaxBlockCount[TransferSelector]
Category	TransferControl
Level	Optional
Interface	IInteger
Access	Read/(Write)
Unit	-
Visibility	Expert
Values	> 0

Controls the maximum number of data blocks that can be stored in the block queue of the selected stream.

20.10 TransferQueueCurrentBlockCount

Name	TransferQueueCurrentBlockCount[TransferSelector]
Category	TransferControl
Level	Optional
Interface	IInteger

Access	Read
Unit	-
Visibility	Expert
Values	-

Returns the number of Block(s) currently in the transfer queue.

20.11 TransferQueueMode

Name	TransferQueueMode[TransferSelector]
Category	TransferControl
Level	Optional
Interface	IEnumeration
Access	Read/(Write)
Unit	-
Visibility	Expert
Values	FirstInFirstOut ...

Specifies the operation mode of the transfer queue.

Possible values are:

- **FirstInFirstOut:** Blocks first In are transferred Out first.
- ...

20.12 TransferStart

Name	TransferStart[TransferSelector]
Category	TransferControl
Level	Optional
Interface	ICommand
Access	(Read)/Write
Unit	-
Visibility	Expert
Values	-

Starts the streaming of data blocks out of the device. This feature must be available when the **TransferControlMode** is set to "UserControlled". If the **TransferStart** feature is not writable (locked), the application should not start the transfer and should avoid using the feature until it becomes writable again.

20.13 TransferStop

Name	TransferStop[TransferSelector]
Category	TransferControl
Level	Optional
Interface	ICommand
Access	(Read)/Write
Unit	-
Visibility	Expert
Values	-

Stops the streaming of data Block(s). The current block transmission will be completed. This feature must be available when the **TransferControlMode** is set to "UserControlled".

20.14 TransferAbort

Name	TransferAbort[TransferSelector]
Category	TransferControl
Level	Optional
Interface	ICommand
Access	(Read)/Write
Unit	-
Visibility	Expert
Values	-

Aborts immediately the streaming of data block(s). Aborting the transfer will result in the lost of the data that is present or currently entering in the block queue. However, the next new block received will be stored in the queue and transferred to the host when the streaming is restarted. If implemented, this feature should be available when the **TransferControlMode** is set to "UserControlled".

20.15 TransferPause

Name	TransferPause[TransferSelector]
Category	TransferControl

Level	Optional
Interface	ICommand
Access	(Read)/Write
Unit	-
Visibility	Guru
Values	-

Pauses the streaming of data Block(s). Pausing the streaming will immediately suspend the ongoing data transfer even if a block is partially transferred. The device will resume its transmission at the reception of a **TransferResume** command.

20.16 TransferResume

Name	TransferResume[TransferSelector]
Category	TransferControl
Level	Optional
Interface	ICommand
Access	(Read)/Write
Unit	-
Visibility	Guru
Values	-

Resumes a data Blocks streaming that was previously paused by a **TransferPause** command.

20.17 TransferTriggerSelector

Name	TransferTriggerSelector[TransferSelector]
Category	TransferControl
Level	Optional
Interface	IEnumeration
Access	Read/Write
Unit	-
Visibility	Guru
Values	TransferStart TransferStop TransferAbort

TransferPause
TransferResume
TransferActive
TransferBurstStart
TransferBurstStop

Selects the type of transfer trigger to configure.

Possible values are:

- **TransferStart:** Selects a trigger to start the transfers.
- **TransferStop:** Selects a trigger to stop the transfers.
- **TransferAbort:** Selects a trigger to abort the transfers.
- **TransferPause:** Selects a trigger to pause the transfers.
- **TransferResume:** Selects a trigger to Resume the transfers.
- **TransferActive:** Selects a trigger to Activate the transfers. This trigger type is used when TriggerActivation is set LevelHigh or levelLow.
- **TransferBurstStart:** Selects a trigger to start the transfer of a burst of frames specified by TransferBurstCount.
- **TransferBurstStop:** Selects a trigger to end the transfer of a burst of frames.

20.18 TransferTriggerMode

Name	TransferTriggerMode[TransferSelector][TransferTriggerSelector]
Category	TransferControl
Level	Recommended
Interface	IEnumeration
Access	Read/Write
Unit	-
Visibility	Guru
Values	Off On

Controls if the selected trigger is active.

Possible values are:

- **Off:** Disables the selected trigger.
- **On:** Enable the selected trigger.

20.19 TransferTriggerSource

Name	TransferTriggerSource[TransferTriggerSelector]
Category	TransferControl
Level	Optional
Interface	IEnumeration
Access	Read/Write
Unit	-
Visibility	Guru
Values	Line0 (If 0 based), Line1, Line2, ... Counter0Start (If 0 based), Counter1Start, Counter2Start, ... Counter0End (If 0 based), Counter1End, Counter2End, ... Timer0Start (If 0 based), Timer1Start, Timer2Start, ... Timer0End (If 0 based), Timer1End, Timer2End, ... LogicBlock0, LogicBlock1, LogicBlock2, ... SoftwareSignal0 (If 0 based), SoftwareSignal1, SoftwareSignal2, ... Action0 (If 0 based), Action1, Action2,

Specifies the signal to use as the trigger source for transfers.

Possible values are:

- **Line0** (If 0 based), **Line1**, **Line2**, ...: Specifies which physical line (or pin) and associated I/O control block to use as external source for the transfer control trigger signal.
- **Counter0Start**, **Counter1Start**, **Counter2Start**, ..., **Counter0End**, **Counter1End**, **Counter2End**, ...: Specifies which of the Counter signal to use as internal source for the transfer control trigger signal.
- **Timer0Start**, **Timer1Start**, **Timer2Start**, ..., **Timer0End**, **Timer1End**, **Timer2End**, ...: Specifies which Timer signal to use as internal source for the transfer control trigger signal.
- **LogicBlock0**, **LogicBlock1**, **LogicBlock2**, ...: Specifies which Logic Block to use as internal source for the transfer control trigger signal.
- **SoftwareSignal0**, **SoftwareSignal1**, **SoftwareSignal2**, ...: Specifies which Software Signal to use as internal source for the transfer control trigger signal.
- **Action0**, **Action1**, **Action2**, ...: Specifies which Action command to use as internal source for the transfer control trigger signal.
- ...

20.20 TransferTriggerActivation

Name	TransferTriggerActivation[TransferTriggerSelector]
Category	TransferControl
Level	Optional
Interface	IEnumeration
Access	Read/Write
Unit	-
Visibility	Guru
Values	RisingEdge FallingEdge AnyEdge LevelHigh LevelLow

Specifies the activation mode of the transfer control trigger.

Possible values are:

- **RisingEdge**: Specifies that the trigger is considered valid on the rising edge of the source signal.
- **FallingEdge**: Specifies that the trigger is considered valid on the falling edge of the source signal.
- **AnyEdge**: Specifies that the trigger is considered valid on the falling or rising edge of the source signal.
- **LevelHigh**: Specifies that the trigger is considered valid as long as the level of the source signal is high. This can apply to TransferActive and TransferPause trigger.
- **LevelLow**: Specifies that the trigger is considered valid as long as the level of the source signal is low. This can apply to TransferActive and TransferPause trigger.

20.21 TransferStatusSelector

Name	TransferStatusSelector[TransferSelector]
Category	TransferControl
Level	Recommended
Interface	IEnumeration
Access	Read/Write
Unit	-
Visibility	Guru
Values	Streaming Paused Stopping

	Stopped QueueOverflow
--	--------------------------

Selects which status of the transfer module to read.

Possible values are:

- **Streaming:** Data blocks are transmitted when enough data is available.
- **Stopping:** Data blocks transmission is stopping. The current block transmission will be completed and the transfer state will stop.
- **Stopped:** Data blocks transmission is stopped.
- **Paused:** Data blocks transmission is suspended immediately.
- **QueueOverflow:** Data blocks queue is in overflow state.

20.22 TransferStatus

Name	TransferStatus[TransferStatusSelector]
Category	TransferControl
Level	Recommended
Interface	IBool
Access	Read
Unit	-
Visibility	Guru
Values	True False

Reads the status of the Transfer module signal selected by TransferStatusSelector.

20.23 TransferComponentSelector

Name	TransferComponentSelector[TransferSelector]
Category	TransferControl
Level	Optional
Interface	IEnumeration
Access	Read/Write
Unit	-
Visibility	Guru

Values	Red Green Blue All
---------------	-----------------------------

Selects the color component for the control of the **TransferStreamChannel** feature.

Possible values are:

- **Red:** The **TransferStreamChannel** feature controls the index of the stream channel for the streaming of the red plane of the planar pixel formats.
- **Green:** The **TransferStreamChannel** feature controls the index of the stream channel for the streaming of the green plane of the planar pixel formats.
- **Blue:** The **TransferStreamChannel** feature controls the index of the stream channel for the streaming of blue plane of the planar pixel formats.
- **All:** The **TransferStreamChannel** feature controls the index of the stream channel for the streaming of all the planes of the planar pixel formats simultaneously or non planar pixel formats.

This feature is only needed if the device supports planar pixel formats.

20.24 TransferStreamChannel

Name	TransferStreamChannel[TransferSelector][TransferComponentSelector]
Category	TransferControl
Level	Optional
Interface	IInteger
Access	Read/Write
Unit	-
Visibility	Guru
Values	>0

Selects the streaming channel that will be used to transfer the selected stream of data. In general, this feature can be omitted and the default streaming channel will be used.

21 3D Scan Control

The 3D scan Control chapter describes the model and features related to the control and acquisition of 3D images.

3D cameras measure geometrical information rather than intensity or color. Typically a 3D camera delivers a range (also called depth or distance) image. In the same way as there are Areascan and Linescan 2D cameras we have many instances of Areascan and Linescan 3D devices.

In general, 3D data needs more auxiliary information than 2D data to interpret the data. Such information is for instance coordinate system used and its location, units used etc. It is recommended to provide chunk data with this information in the image streams to facilitate the acquisition engine understanding the data.

Areascan 3D

Areascan 3D cameras can give a range image of a static scene, typically without any visible motion of the camera.

Areascan 3D cameras typically acquire a complete 3D range map or point cloud in a single shot. Examples are stereo cameras, time-of-flight cameras and the fixed-pattern triangulation cameras. Other Areascan 3D cameras use multiple exposures with different illumination or acquisition locations and use reconstruction methods based on e.g. triangulation, depth-from-focus or shape from shading.

Typically the output can be viewed as an image where intensity or color represents range. This type of single view-point image is technically called a 2.5D range image. For example, for each sensor (image) coordinate only one Z, or range coordinate, is possible.

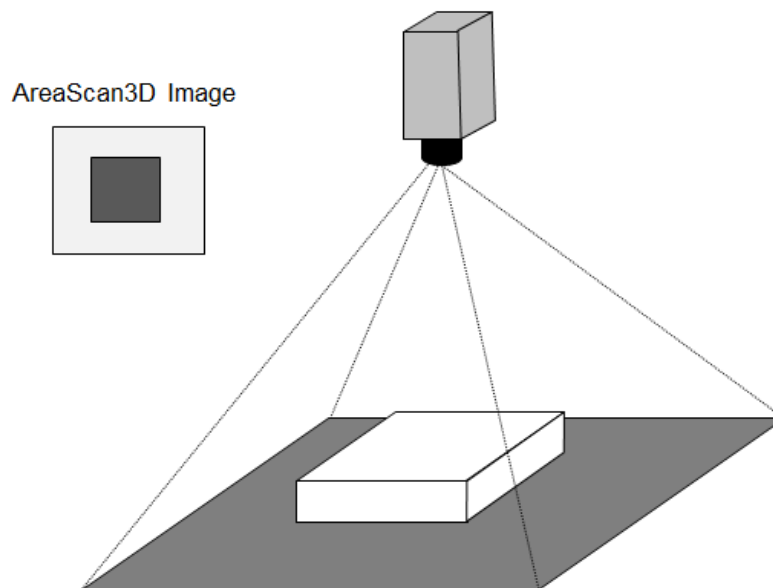

Figure 21-1: 3D Areascan camera.

Point Clouds

Through calibration procedures one or more 2.5D range images can be converted to a 3D point cloud. In a 3D point cloud multiple Z values are possible for each X and Y coordinate. Typically such a point cloud is organized, i.e. it can be represented as 3 separate images, and neighbouring pixels typically are neighbours also in 3D space. However, even in an organized point cloud it is not guaranteed that neighbouring pixel positions represents neighbouring points in the 3D world.

In general we do not distinguish between cameras delivering a 2.5D range map and 3D point cloud data in this document.

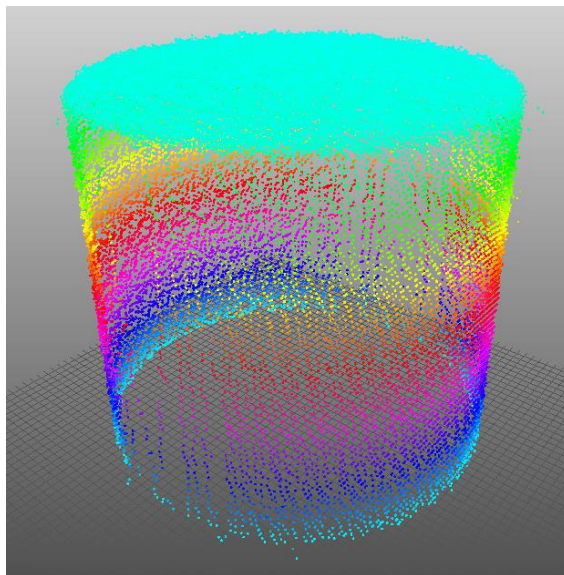

Figure 21-2: 3D point cloud data set representing a cylinder.

Linescan 3D

Linescan 3D devices acquire a contour of the target in each acquisition and typically use linear object or camera motion to image complete 3D objects. The final result is typically 3D images of objects in the same sense as for Areascan 3D cameras, but the Y (scan) direction size may be variable and the coordinate values increase/decrease continuously with the motion.

Linescan 3D devices include laser plane triangulation (sheet-of-light) and time-of-flight laser scanners with 1D scanning. There are also stereo linescan cameras.

For the typical Linescan 3D camera the distance between scans is fixed, with the camera triggered from a motion sensing device such as an encoder. In this case the scale information for this coordinate can be expressed via the `Scan3dCoordinateScale` feature which is part of the `Scan3dControl`.

It is also common with fixed acquisition time to use an encoder value to indicate the sampling position. Chunk data can then be used to mark each scan line with the encoder counter, and together with a scale factor for the counter, it is possible to reconstruct the position for the data along the motion direction.

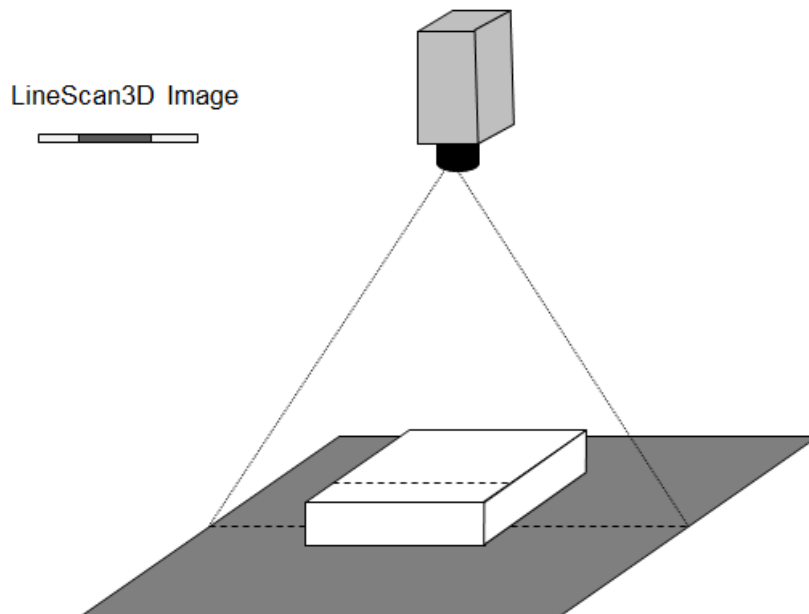

Figure 21-3: 3D Linescan camera.

Invalid Data

A 3D camera typically delivers data formatted as images representing distance. Due to occlusion and object reflectance properties all points in such a 3D image typically do not hold valid measurements. This is generally called invalid or missing data and care must be taken when processing 3D images which contain such data.

To efficiently handle invalid data the 3D extension includes a Confidence (mask) image concept to mark valid pixels. The concept allows a weighted confidence as well as a binary valid /non-valid. As an alternative to mask images it is possible to define a certain (out-of-bounds) value of the range data which indicates invalid data. It is common to use e.g. 0 or a high value outside the valid range of actual measurement to indicate invalid data. The use of NaN as invalid is discouraged due to possible processing overhead.

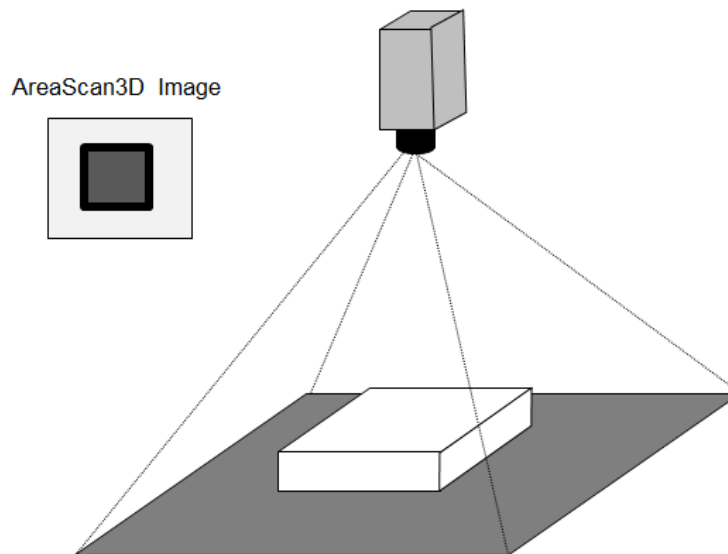

Figure 21-4: 3D invalid or missing data due to occlusion around the box (in black).

21.13D Scan usage model and configuration scenarios

This section illustrates few possible 3D system setups and how sensors, regions, data formatting and coordinate systems can be defined. The SFNC and PFNC definitions are used in pseudo code examples covering the main setup points. Note that due to naming restriction in some programming language, the 3D control features use the prefix Scan3d instead of 3dScan.

Default 3D configuration:

The default configuration uses Cartesian coordinates with mm units in the Anchored coordinate system. In the examples below the features Scan3dCoordinateSystem, Scan3dDistanceUnit and Scan3dCoordinateSystemReference are not used unless a value different from the default is used.

Also, for the default basic 3D system examples, only a single sensor with a single region is used (i.e. No SourceSelector or RegionSelector used). For more detailed examples see the chapter 21.3 (3D Device data output control).

Multisource:

The SFNC standard covers cameras with multiple sources using the SourceControl and the SourceSelector concept. This is aimed at cameras with multiple physical sensors such as color and IR, but can also be used with a single physical sensor exposing multiple virtual sensors (sources). This is applicable for advanced 3D cameras. Multiple sources can be used when the camera has multiple physical sources that deliver data, as in a stereo camera, or when different regions on a physical sensor have different 3D coordinate systems as illustrated in some of the use cases below.

21.1.1 3D acquisition devices configuration examples

Basic Areascan 3D camera:

This example shows the setup for a basic 3D camera acquiring uncalibrated range maps from a sensor, and reading the min/max range of the resulting data.

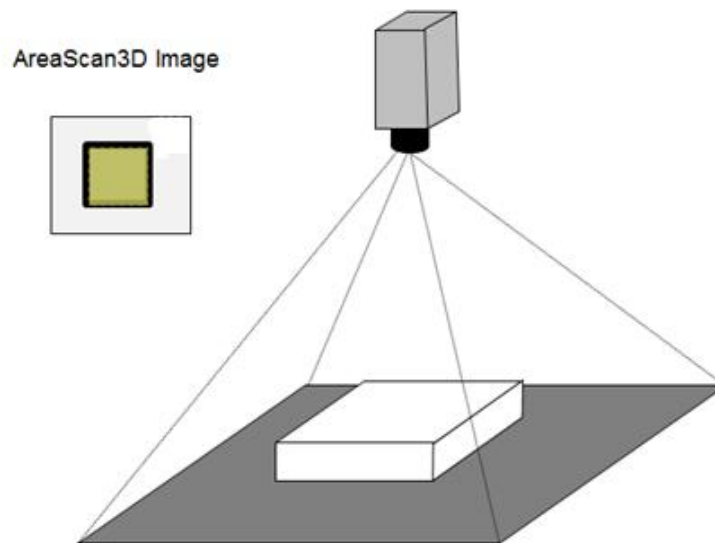

Figure 21-5: 3D Areascan camera Range acquisition.

```
// Basic Areascan 3D camera.
// *****

// 3D output as range map (16 bit integers),
// Setup acquisition position and size (full sensor).
OffsetX = 0;
OffsetY = 0;
Width   = 2048;
Height  = 2048;

// Setup output Image Component and Pixel Format.
ComponentSelector      = Range;
ComponentEnable[Range] = True;
PixelFormat[Range]     = Coord3D_C16;

// Scan3D setup of coordinate system information (Uncalibrated Range Map (2.5D) output).
Scan3dOutputMode = UncalibratedC;

// Get dynamic range information in that output mode.
Scan3dCoordinateSelector = CoordinateC;
minRangeValue = Scan3dAxisMin[CoordinateC]; // e.g. 1
```

```
maxRangeValue = Scan3dAxisMax[CoordinateC]; // e.g. 4095
```

This 3D data can be transmitted without multi components transfer, and this would also be possible if the result was a full point cloud transmitted in one of the "ABC" formats.

Areascan 3D camera with Regions:

This type of camera could be for example a time-of-flight array camera, or any other device delivering a 3D range image for each exposure of its unique sensor.

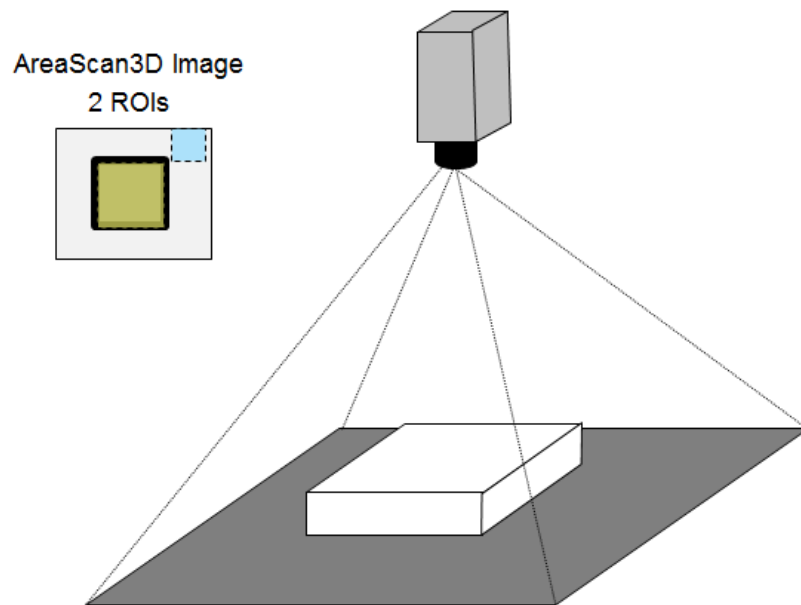

Figure 21-6: 3D areascan camera Range acquisition with multiples Regions.

The main part of the 3D setup in this case could be:

```
// Areascan 3D camera with 2 Regions.
// *****

// Scan3D Control setup of coordinate system information.
// 3D point cloud out in sensor pixel grid organization.
//
// Note: In this example use both Regions output data in the same coordinate system.
//       No Scan3dExtractionSelector or Scan3dExtraction regions are therefore needed.
//       In a more general case usage of RegionX -> Scan3dExtractionY can overcome this.
Scan3dOutputMode   = CalibratedABC_Grid;
Scan3dDistanceUnit = Inch; // Set non-default value.

// 3D Scan Region 0: 3D Range as point cloud and Intensity.
RegionSelector     = Region0;
RegionMode[Region0] = On;
```

```
OffsetX[Region0]    = 512;
OffsetY[Region0]    = 512;
Width[Region0]      = 512;
Height[Region0]     = 512;
```

```
// Setup Components acquisition for selected 3D Region 0.
```

```
ComponentSelector[Region0]    = Range;
ComponentEnable[Region0][Range] = True;
PixelFormat[Region0][Range]   = Coord3D_ABC8_Planar;
ComponentSelector[Region0]    = Intensity;
ComponentEnable[Region0][Intensity] = True;
PixelFormat[Region0][Intensity] = Mono8;
```

```
// 3D Scan Region 1: 3D Range as point cloud and Intensity.
```

```
RegionSelector    = Region1;
RegionMode[Region1] = On;
OffsetX[Region1]  = 1024;
OffsetY[Region1]  = 0;
Width[Region1]    = 400;
Height[Region1]   = 256;
```

```
// Setup Components acquisition for selected 3D Region 1.
```

```
ComponentSelector[Region1]    = Range;
ComponentEnable[Region1][Range] = True;
PixelFormat[Region1][Range]   = Coord3D_ABC8_Planar;
ComponentSelector[Region0]    = Intensity;
ComponentEnable[Region0][Intensity] = True;
PixelFormat[Region0][Intensity] = Mono8;
```

```
// Get Scale & offset transforming from transmitted to world coordinates.
```

```
// Values in the comments are based on the following example FOV & data use:
```

```
// FOV ~25x25x25 inch, X & Y data covers [-12.5,12.5] inch range Z data in [25,50] inch range.
```

```
// Invalid data tagged as 0 in all Z coordinate image.
```

```
Scan3dCoordinateSelector = CoordinateA; // CoordinateA -> X in Cartesian system.
scaleA = Scan3dCoordinateScale[CoordinateA]; // e.g. 0.1
offsetA = Scan3dCoordinateOffset[CoordinateA]; // e.g. -12.5
bboxMinA = Scan3dAxisMin[CoordinateA]; // e.g. 1
bboxMaxA = Scan3dAxisMax[CoordinateA]; // e.g. 250
```

```
Scan3dCoordinateSelector = CoordinateB; // CoordinateB -> Y in Cartesian system.
scaleB = Scan3dCoordinateScale[CoordinateB]; // e.g. 0.1
offsetB = Scan3dCoordinateOffset[CoordinateB]; // e.g. -12.5
bboxMinB = Scan3dAxisMin[CoordinateB]; // e.g. 1
bboxMaxB = Scan3dAxisMax[CoordinateB]; // e.g. 250
```

```
Scan3dCoordinateSelector = CoordinateC; // CoordinateC -> Z in Cartesian system.
// Negative scale & large offset to switch Z.
scaleC = Scan3dCoordinateScale[CoordinateC]; // e.g. -0.1
offsetC = Scan3dCoordinateOffset[CoordinateC]; // e.g. 50
if (Scan3dInvalidDataFlag[CoordinateC] == true)
    invalidValueC = Scan3dInvalidDataValue[CoordinateC]; // e.g. = 0
bboxMinC = Scan3dAxisMin[CoordinateC]; // e.g. 1
bboxMaxC = Scan3dAxisMax[CoordinateC]; // e.g. 250
```

The data output could in this case be formatted as:

Component	Part	Source	Region	data type	data format
Range	0	1	Region 0	3D plane of tri planar image	Coord3D_A8
Range	1	1	Region 0	3D plane of tri planar image	Coord3D_B8
Range	2	1	Region 0	3D plane of tri planar image	Coord3D_C8
Intensity	3	1	Region 0	2D image	Mono8
Range	4	1	Region 1	3D plane of tri planar image	Coord3D_A8
Range	5	1	Region 1	3D plane of tri planar image	Coord3D_B8
Range	6	1	Region 1	3D plane of tri planar image	Coord3D_C8
Intensity	7	1	Region 1	2D image	Mono8
Chunk data	8	-	All components chunk data if enabled (not shown).	(Chunk data)	GenICam Chunk

Using Transformed coordinate system:

The following code shows how to setup a coordinate system transform, and query the transformed system location and orientation.

```
// Using Transformed coordinate system.
// *****

// Scan3D Control setup of coordinate system information.
// 3D point cloud out and in sensor pixel grid organization.
Scan3dOutputMode = CalibratedABC_Grid;
Scan3dCoordinateSystemReference = Transformed;

// Setup of transform from Anchor location:
// Rotation vector [30,10,-40] degrees.
// Translation vector [1000,200,403] mm.
Scan3dCoordinateTransformSelector = RotationX;
Scan3dTransformValue[RotationX] = 30;
Scan3dCoordinateTransformSelector = RotationY;
Scan3dTransformValue[RotationY] = 10;
Scan3dCoordinateTransformSelector = RotationZ;
Scan3dTransformValue[RotationZ] = -40;
Scan3dCoordinateTransformSelector = TranslationX;
Scan3dTransformValue[TranslationX] = 1000;
Scan3dCoordinateTransformSelector = TranslationY;
Scan3dTransformValue[TranslationY] = 200;
Scan3dCoordinateTransformSelector = TranslationZ;
Scan3dTransformValue[TranslationZ] = 403;

// Read the resulting transformed origin & pose relative to Reference position.
Scan3dCoordinateReferenceSelector = TranslationX;
```

```
originX = Scan3dCoordinateReferenceValue[TranslationX];
Scan3dCoordinateReferenceSelector = TranslationY;
originY = Scan3dCoordinateReferenceValue[TranslationY];
Scan3dCoordinateReferenceSelector = TranslationZ;
originZ = Scan3dCoordinateReferenceValue[TranslationZ];
Scan3dCoordinateReferenceSelector = RotationX;
poseX   = Scan3dCoordinateReferenceValue[RotationX];
Scan3dCoordinateReferenceSelector = RotationY;
poseY   = Scan3dCoordinateReferenceValue[RotationY];
Scan3dCoordinateReferenceSelector = RotationZ;
poseZ   = Scan3dCoordinateReferenceValue[RotationZ];
```

Stereo 3D Camera with Regions and Sources:

In a stereo system there are (at least) two image sensors. Typically one of them is the "master" and the disparity (lateral matching pixel position difference, which is approximately inversely proportional to range) between this and the other is measured and output. It is also possible to be able to switch which sensor is master, or even create a virtual centered 3rd sensor view.

Here it is natural to view the system as having multiple sources, where each source potentially has its own 3D setup.

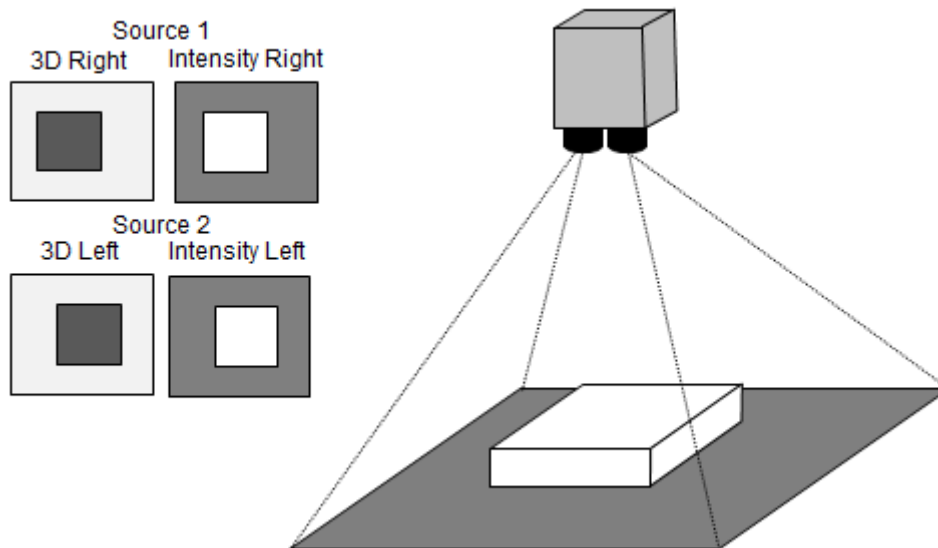

Figure 21-7: Stereo cameras generating individual 3D and intensity images for each sensors.

The main part of the 3D setup is:

```
// 3D scan with Stereo Camera.
// *****

// Output Disparity map & Intensity from a 2 sensors device.
// The 2 sensors features can be controled using SourceSelector = Source1 or Source2.
// Using Source1 here to get the combined resulting disparity out.
```

```
// No explicit Region selector is used in the example.
SourceSelector = Source1;

// Setup 3D formatting, uncalibrated 2.5D disparity-coded range map output.
// Disparity has e.g. 0.25 (pixel) resolution and an offset 50 (pixels).
Scan3dOutputMode[Source1] = Disparity; // This can change Pixel Format, so set before query.
OffsetX[Source1] = 0;
OffsetY[Source1] = 0;
Width[Source1] = 2048;
Height[Source1] = 1024;

// Setup acquisition for selected sensor
ComponentSelector[Source1] = Disparity; // Disparity
ComponentEnable[Source1][Disparity] = True;
PixelFormat[Source1][Disparity] = Coord3D_C16; // 3D disparity output format.
ComponentSelector[Source1] = Confidence; //Confidence
ComponentEnable[Source1][Confidence] = True;
PixelFormat[Source1][Confidence] = Confidence8;
ComponentSelector[Source1] = Intensity; // Intensity
ComponentEnable[Source1][Intensity] = True;
PixelFormat[Source1][Intensity] = Mono8 // 2D Sensor 1 output.

// Get Disparity informations.
Scan3dCoordinateSelector[Source1] = CoordinateC; // Coordinate C -> Disparity.
scaleC = Scan3dCoordinateScale[Source1][CoordinateC]; // e.g. 0.25
offsetC = Scan3dCoordinateOffset[Source1][CoordinateC]; // e.g. 50
invalidFlagC = Scan3dInvalidDataFlag[Source1][CoordinateC]; // Invalid flag state.
invalidValueC = Scan3dInvalidDataValue[Source1][CoordinateC]; // e.g. 0
bboxMinC = Scan3dAxisMin[Source1][CoordinateC]; // e.g. 1
bboxMaxC = Scan3dAxisMax[Source1][CoordinateC]; // e.g. = 200
```

The data output could in this case, and with the second sensor setup as the first (not shown) could be formatted as:

Component	Part	Source	Region	data type	data format
Disparity	0	1	Region 0	3D disparity image	Coord3D_C16
Confidence	1	1	Region 0	3D confidence image	Confidence8
Intensity	2	1	Region 0	2D image	Mono8
Disparity	3	2	Region 0	3D disparity image	Coord3D_C16
Confidence	4	2	Region 0	3D confidence image	Confidence8
Intensity	5	2	Region 0	2D image	Mono8
Chunk data	(6)	-	All components chunk data if enabled (not shown).	(Chunk data)	GenICam Chunk

If the setup is changed to have a data output with a 3D point cloud planar image by replacing:

```
ComponentSelector[Source1]      = Disparity;    // Disparity
ComponentEnable[Source1][Disparity] = True;
PixelFormat[Source1][Disparity]  = Coord3D_C16; // 3D disparity output format.
```

by

```
ComponentSelector[Source1]      = Range;    // Range
ComponentEnable[Source1][Range] = True;
PixelFormat[Source1][Range]    = Coord3D_ABC16_Planar; // 3D point cloud output format.
```

formatting could be defined as:

Component	Part	Source	Region	data type	data format
Range	0	1	Region 0	3D plane of tri planar image	Coord3D_A16
Range	1	1	Region 0	3D plane of tri planar image	Coord3D_B16
Range	2	1	Region 0	3D plane of tri planar image	Coord3D_C16
Confidence	3	1	Region 0	3D confidence image	Confidence8
Intensity	4	1	Region 0	2D image	Mono8
Range	5	2	Region 0	3D plane of tri planar image	Coord3D_A16
Range	6	2	Region 0	3D plane of tri planar image	Coord3D_B16
Range	7	2	Region 0	3D plane of tri planar image	Coord3D_C16
Confidence	8	2	Region 0	3D confidence image	Confidence8
Intensity	9	2	Region 0	2D image	Mono8
Chunk data	10	-	All components chunk data if enabled (not shown).	(Chunk data)	GenICam Chunk

Linescan 3D camera:

The typical setup for a linescan laser triangulation setup is shown below.

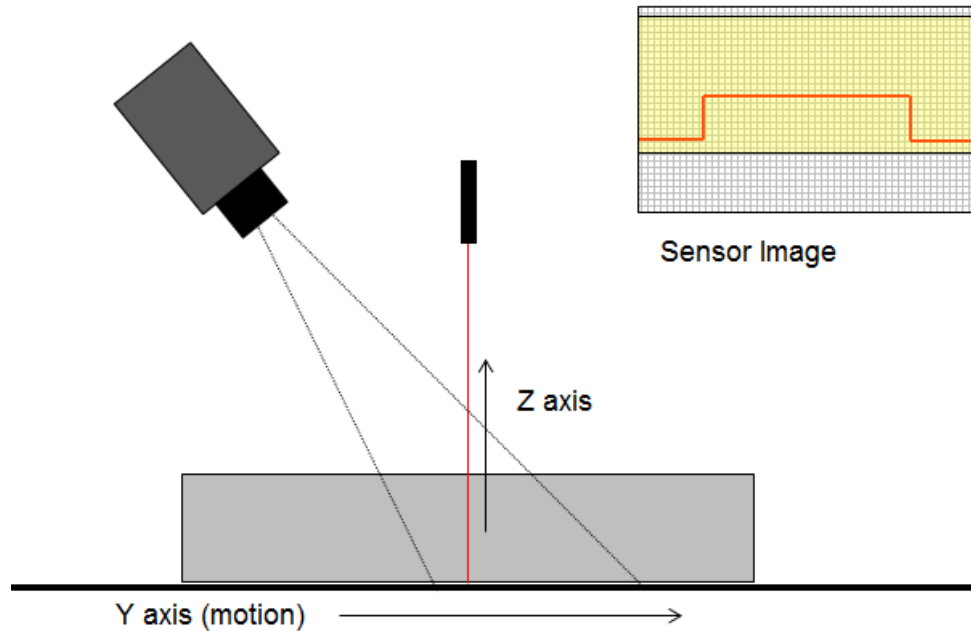

Figure 21-8: Laser linescan triangulation sensor with vertical laser.

An example of how the main part of the 3D setup for a laser triangulation with a vertical laser, extracting 3D, reflectance and laser scatter information, and having fixed sampling interval between scan lines could look like in this case is:

```
// Linescan 3D Camera examples.
// *****

// Range, Reflectance and laser Scatter is acquired (all pixel mapped).
// Setup 3D formatting, 1D rectified 2.5D range map.
// Basic device with no RegionSelector.
// Coordinate system is Cartesian, rectification gives A/B scale/offset.
Scan3dOutputMode          = RectifiedC;

// Setup sensor acquisition Region.
RegionSelector            = Region0;
Width[Region0]            = 2000;
Height[Region0]           = 1000;
OffsetX[Region0]          = 0;
OffsetY[Region0]          = 50;

// Setup 3D scan output region (different output size).
RegionSelector            = Scan3dExtraction0;
Width[Scan3dExtraction0]  = 2000;
Height[Scan3dExtraction0] = 2000;
OffsetX[Scan3dExtraction0] = 0;
```



```

OffsetY[Scan3dExtraction0] = 0;

ComponentSelector[Scan3dExtraction0]           = Range;
ComponentEnable[Scan3dExtraction0][Range]      = True;
PixelFormat[Scan3dExtraction0][Range]         = Coord3D_C16;
ComponentSelector[Scan3dExtraction0]           = Reflectance;
ComponentEnable[Scan3dExtraction0][Reflectance] = True;
PixelFormat[Scan3dExtraction0][Reflectance]    = Mono8;
ComponentSelector[Scan3dExtraction0]           = Scatter;
ComponentEnable[Scan3dExtraction0][Scatter]    = True;
PixelFormat[Scan3dExtraction0][Scatter]        = Mono16;

// Sensor has 2000 pixels across, FOV range ~200 mm.
// Anchor system is "at edge of belt" Z towards camera.
// Invalid data tagged as 2047 in range map.
// Data is 16 bit unsigned integers.
// X axis has 0.5 mm per pixel in the rectified image, covering [-0.5,0.5] meter.
Scan3dCoordinateSelector = CoordinateA;          // CoordinateA -> X
scaleA = Scan3dCoordinateScale[CoordinateA];    // e.g. 0.5
offsetA = Scan3dCoordinateOffset[CoordinateA];  // e.g. -500

// Coordinate B scaling
Scan3dCoordinateSelector = CoordinateB;          //CoordinateB -> Y
scaleB = Scan3dCoordinateScale[CoordinateB] ;   // e.g. 0.1
offsetB = Scan3dCoordinateOffset[CoordinateB];  // e.g. -450

// Example : Z data has 0.1 mm per increment, no offset,
// 2047 is invalid data flag, 0-2000 valid data range.
Scan3dCoordinateSelector = CoordinateC;          // CoordinateC -> Z
scaleC = Scan3dCoordinateScale[CoordinateC];    // e.g. 0.1
offsetC = Scan3dCoordinateOffset[CoordinateC];  // e.g. 0
invalidFlagC = Scan3dInvalidDataFlag[CoordinateC]; // Invalid flag state.
invalidValueC = Scan3dInvalidDataValue[CoordinateC]; // e.g. 2047
bboxMinC = Scan3dAxisMin[CoordinateC];         // e.g. 0
bboxMaxC = Scan3dAxisMax[CoordinateC];         // e.g. 2000
    
```

Alternatively the information for scaling and offset is read from the chunk data for each image line in the RectifiedC_Linescan mode using the following pseudo code:

```

// Linescan 3D Camera "rectified".
// *****

// Basic device (No Region or Scan3dExtraction Selectors).
Scan3dOutputMode = RectifiedC_Linescan; // Sets B (Y) position given by encoder.

// Setup to use Chunk encoder data for Y scaling.
ChunkModeActive = True;
ChunkSelector = Image;
ChunkEnable[ChunkSelector] = True;
ChunkSelector = Scan3dCoordinateScale;
ChunkEnable[ChunkSelector] = True;
ChunkSelector = Scan3dCoordinateOffset;
ChunkEnable[ChunkSelector] = True;
ChunkSelector = EncoderValue;
    
```

```
ChunkEnable[ChunkSelector] = True;
```

```
// Reading chunk data from received buffer
ChunkScan3dCoordinateSelector = CoordinateA;           // CoordinateA -> X
scaleA = ChunkScan3dCoordinateScale[CoordinateA];     // e.g. 0.5
offsetA = ChunkScan3dCoordinateOffset[CoordinateA];   // e.g. -500

// Coordinate B given by encoder mark in Chunk data, still scaled & offset as normal.
ChunkScan3dCoordinateSelector = CoordinateB;           // CS = CoordinateB -> Y
scaleB = ChunkScan3dCoordinateScale [CoordinateB];    // Scale of Encoder step.
offsetB = ChunkScan3dCoordinateOffset[CoordinateB];   // offset for this image along belt.
for (row = 0; row < Nrows; row++)
{
    ChunkScanLineSelector = row;
    // Note: Here encoder wrap-around handling is not illustrated.
    coordB[row] = ChunkEncoderValue[ChunkScanLineSelector] * scaleB + offsetB;
}
ChunkScan3dCoordinateSelector = CoordinateC;           // CoordinateC -> Z
scaleC = ChunkScan3dCoordinateScale[CoordinateC];     // e.g. 0.1
offsetC = ChunkScan3dCoordinateOffset[CoordinateC];   // e.g. 0
```

The data output could in this case be formatted as:

Component	Part	Source	Region	data type	data format
Range	0	1	Scan3dExtraction 0	3D plane of tri planar image	Coord3D_C16
Reflectance	1	1	Scan3dExtraction 0	3D plane of tri planar image	Mono8
Scatter	2	1	Scan3dExtraction 0	2D image	Mono16
Chunk data	(3)	-	All components chunk data if enabled (not shown).	(Chunk data)	GenICam Chunk

Linescan 3D camera with multiple regions and coordinate systems:

With a line-scan camera using laser triangulation and multiple lasers the setup could look as in this example, where different regions are setup with different processing modules and coordinate system details such as scale and anchor position.

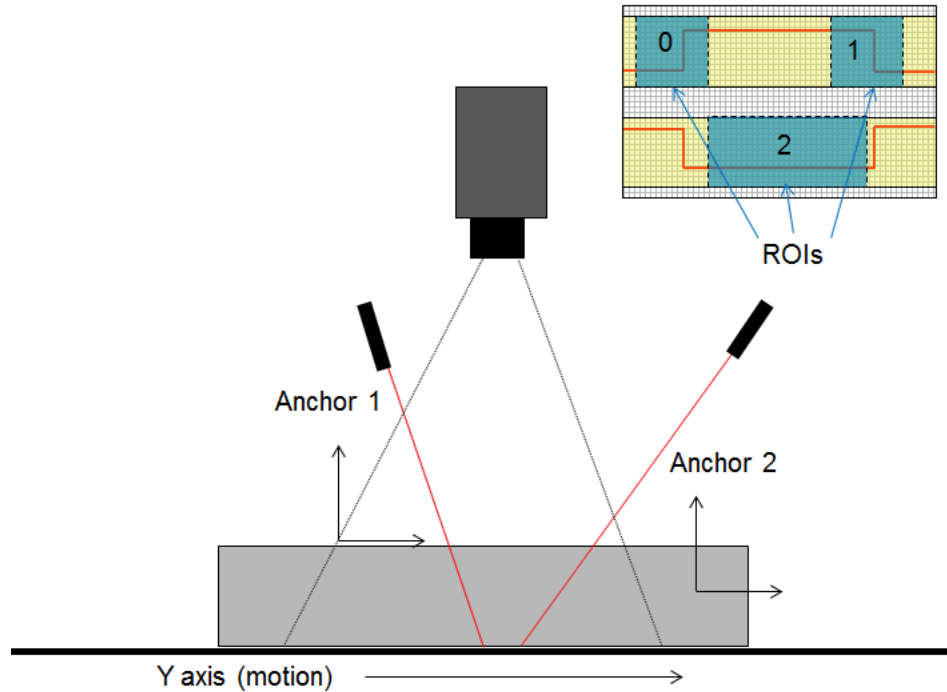

Figure 21-9: Laser linescan triangulation with multiple Regions and coordinate systems.

An example of how the main part of the 3D laser triangulation setup for the 3 regions of the sensors could look like:

```
// Linescan 3D Camera of Regions with different coordinate outputs.
// *****

// 1. Dataflow: Region0 -> Scan3dExtraction0 -> Stream0
// -----

// 1.a. Setup Sensor Region output.
RegionSelector      = Region0;
RegionMode[Region0] = On;      // Transmit Sensor Region.
Height[Region0]    = 256;     // Number of rows on sensor.
Width[Region0]     = 100;     // Number of columns on sensor.
OffsetX[Region0]   = 25;     // Position on sensor.
OffsetY[Region0]   = 25;     // Position on sensor.

// 1.b. Setup 3D Processing Module source and parameters.
Scan3dExtractionSelector      = Scan3dExtraction0;
Scan3dOutputMode[Scan3dExtraction0] = CalibratedC;
Scan3dExtractionSource[Scan3dExtraction0] = Region0;
Scan3dExtractionMethod[Scan3dExtraction0] = Default;
```

```

Scan3dCoordinateOffset[Scan3dExtraction0] = 125;
Scan3dCoordinateScale[Scan3dExtraction0][CoordinateC] = 0.14;

// 1.c. Setup 3D Processing output Region and Components.
RegionSelector          = Scan3dExtraction0;
RegionMode[Scan3dExtraction0] = On; // Transmit 3D Scan Extraction.
Width[Scan3dExtraction0]   = 100; // Number of columns output buffer.
Height[Scan3dExtraction0]  = 500; // Scans/Rows per output buffer.
ComponentSelector[Scan3dExtraction0] = Range;
ComponentEnable[Scan3dExtraction0][Range] = True;
PixelFormat[Scan3dExtraction0][Range]   = Coord3D_ABC32f;

// 2. Dataflow: Region1 -> Scan3dExtraction1 -> Stream0
// -----

// 2.a. Setup Sensor Region output.
RegionSelector          = Region1;
RegionMode[Region1]    = On; // Transmit Sensor Region.
Height[Region1]        = 256; // Number of rows on sensor.
Width[Region1]         = 100; // Number of columns on sensor.
OffsetX[Region1]       = 512; // Position on sensor.
OffsetY[Region1]       = 25;  // Position on sensor.

// 2.b. Setup 3D Processing Module source and parameters.
Scan3dExtractionSelector = Scan3dExtraction1;
Scan3dOutputMode[Scan3dExtraction1] = CalibratedC;
Scan3dExtractionSource[Scan3dExtraction1] = Region1;
Scan3dExtractionMethod[Scan3dExtraction1] = Default;
Scan3dCoordinateOffset[Scan3dExtraction1] = 125;
Scan3dCoordinateScale[Scan3dExtraction1][CoordinateC] = 0.14;

// 2.c. Setup Processing Region functionality
RegionSelector          = Scan3dExtraction1;
RegionMode[Scan3dExtraction1] = On; // Transmit 3D Scan Extraction.
Width[Scan3dExtraction1]   = 100; // Number of columns output buffer.
Height[Scan3dExtraction1]  = 500; // Scans per buffer.
ComponentSelector[Scan3dExtraction1] = Range;
ComponentEnable[Scan3dExtraction1][Range] = True;
PixelFormat[Scan3dExtraction1][Range]   = Coord3D_ABC32f;

// 3. Dataflow: Region2 -> Scan3dExtraction2 -> Stream0
// -----

// 3.a. Setup Sensor Region output.
RegionSelector          = Region2;
RegionMode[Region2]    = On; // Transmit Sensor Region.
Height[Region2]        = 256; // Number of rows on sensor.
Width[Region2]         = 200; // Number of columns on sensor.
OffsetX[Region2]       = 50;  // position on sensor.
OffsetY[Region2]       = 400; // position on sensor.

// 3.b. Setup 3D Processing Module source and parameters.
Scan3dExtractionSelector = Scan3dExtraction2;
Scan3dOutputMode[Scan3dExtraction2] = CalibratedC;
Scan3dExtractionSource[Scan3dExtraction2] = Region2;
Scan3dExtractionMethod[Scan3dExtraction2] = Default;

```

```
Scan3dCoordinateOffset[Scan3dExtraction2] = 225;
Scan3dCoordinateScale[Scan3dExtraction2][CoordinateC] = -0.1;
```

```
// 3.c. Setup Processing Region functionality.
RegionSelector          = Scan3dExtraction2;
RegionMode[Scan3dExtraction2] = 0n; // Transmit 3D Scan Extraction.
Width[Scan3dExtraction2]   = 100; // Number of columns output buffer.
Height[Scan3dExtraction2]  = 500; // Scans per buffer.
ComponentSelector[Scan3dExtraction2] = Range;
ComponentEnable[Scan3dExtraction2][Range] = True;
PixelFormat[Scan3dExtraction2][Range] = Coord3D_ABC32f;
```

The data output could in this case be formatted as:

Component	Part	Source	Region	data type	data format
Range	0	1	Scan3dExtraction 0	3D point cloud image	Coord3D_ABC32f
Range	1	1	Scan3dExtraction 1	3D point cloud image	Coord3D_ABC32f
Range	2	1	Scan3dExtraction 2	3D point cloud image	Coord3D_ABC32f
Chunk data	(3)	-	All components chunk data if enabled (not shown).	(Chunk data)	GenICam Chunk

Calculating World Coordinates:

There are multiple methods on how to transform transmitted coordinates to world coordinates using the scale and offsets. The Scan3dOutputMode defines which method is applicable, if the mode is rectified, the X and/or Y coordinates are implicit and the world coordinates are calculated from the pixel coordinates.

In uncalibrated data transfer scaling and offset can also be used to allow meaningful scaling, for instance to allow mapping the result to the sensors coordinate system.

The pseudo code shows how to read and use scale and offset in a full 3D calibrated image using ChunkData. The SourceID and RegionID information for a component/part should be given by the TransportLayer, so that the selectors in the ChunkData can be set correctly.

```
// Reading chunk data from received buffer and scaling 3D image to world coordinates.
// For the Scan3dExtraction0 processing Region:
ChunkRegionSelector = Scan3dExtraction0;
CoordinateSystem = ChunkScan3dCoordinateSystem[Scan3dExtraction0]; // Example is for Cartesian
ScanMode = ChunkScan3dOutputMode[Scan3dExtraction0];

if (ScanMode == CalibratedABC_Grid)
{
    // Calculating World coordinates - Framescan.
    // *****
    // CoordinateA -> X
    ChunkScan3dCoordinateSelector = CoordinateA;
```

```

scaleA = ChunkScan3dCoordinateScale[Scan3dExtraction0][CoordinateA];
offsetA = ChunkScan3dCoordinateOffset[Scan3dExtraction0][CoordinateA];
// CoordinateB -> Y
ChunkScan3dCoordinateSelector = CoordinateB;
scaleB = ChunkScan3dCoordinateScale[Scan3dExtraction0][CoordinateB];
offsetB = ChunkScan3dCoordinateOffset[Scan3dExtraction0][CoordinateB];
// CoordinateC -> Z
ChunkScan3dCoordinateSelector = CoordinateC;
scaleC = ChunkScan3dCoordinateScale[Scan3dExtraction0][CoordinateC];
offsetC = ChunkScan3dCoordinateOffset[Scan3dExtraction0][CoordinateC];
for (row = 0; row < Height; row++)
{
    for (col = 0; col < Width; col++)
    {
        xCoord [row,col]= imageA [row,col]*scaleA+offsetA;
        yCoord [row,col]= imageB [row,col]*scaleB+offsetB;
        zCoord [row,col]= imageC [row,col]*scaleC+offsetC;
    }
}
}
if (ScanMode = CalibratedACLLineScan)
{
    // Calculating World coordinates - Linescan.
    // *****

    // Reading chunk data from received buffer and scaling 3D image to world coordinates.
    // The image is in Cartesian coordinates.
    // CoordinateA -> X
    ChunkScan3dCoordinateSelector = CoordinateA;
    scaleA = ChunkScan3dCoordinateScale[Scan3dExtraction0][CoordinateA];
    offsetA = ChunkScan3dCoordinateOffset[Scan3dExtraction0][CoordinateA];
    // CoordinateB -> Y
    ChunkScan3dCoordinateSelector = CoordinateB;
    scaleB = ChunkScan3dCoordinateScale[Scan3dExtraction0][CoordinateB];
    offsetB = ChunkScan3dCoordinateOffset[Scan3dExtraction0][CoordinateB];
    // CoordinateC -> Z
    ChunkScan3dCoordinateSelector = CoordinateC;
    scaleC = ChunkScan3dCoordinateScale[Scan3dExtraction0][CoordinateC];
    offsetC = ChunkScan3dCoordinateOffset[Scan3dExtraction0][CoordinateC];

    for (row = 0; row < Height; row++)
    {
        for (col = 0; col < Width; col++)
        {
            xCoord[row, col] = imageA[row, col] * scaleA + offsetA;
            ChunkScanLineSelector = row;
            // Note: Here encoder wrap-around handling is not illustrated.
            yCoord [row,col] = ChunkEncoderValue[ChunkScanLineSelector]*scaleB+offsetB;
            zCoord [row,col] = imageC [row,col]*scaleC+offsetC;
        }
    }
}
}
if (ScanMode == RectifiedC)
{

```

```

// Calculating World coordinates - Rectified.
// *****

// Reading chunk data from received buffer and scaling Rectified image
// CoordinateA -> X
ChunkScan3dCoordinateSelector = CoordinateA;
scaleA = ChunkScan3dCoordinateScale[Scan3dExtraction0][CoordinateA];
offsetA = ChunkScan3dCoordinateOffset[Scan3dExtraction0][CoordinateA];
// CoordinateB -> Y
ChunkScan3dCoordinateSelector = CoordinateB;
scaleB = ChunkScan3dCoordinateScale[Scan3dExtraction0][CoordinateB];
offsetB = ChunkScan3dCoordinateOffset[Scan3dExtraction0][CoordinateB];
// CoordinateC -> Z
ChunkScan3dCoordinateSelector = CoordinateC;
scaleC = ChunkScan3dCoordinateScale[Scan3dExtraction0][CoordinateC];
offsetC = ChunkScan3dCoordinateOffset[Scan3dExtraction0][CoordinateC];

for (row = 0; row < Height; row++)
{
    for (col = 0; col < Width; col++)
    {
        xCoord [row,col] = col*scaleA+offsetA;
        yCoord [row,col] = row*scaleB+offsetB;
        zCoord [row,col] = imageC[row,col]*scaleC+offsetC;
    }
}
}

```

21.2 Formatting and interpreting 3D data

The 3d Scan Control relates to what the transmitted 3D data represents, i.e. to formatting and interpreting 3D data from a sensor. Scan3dControl extends the Image Format Control section, and there is a dependency between Scan3dOutputFormat and PixelFormat. That is, for a given OutputFormat of the 3D data there is a limited number of valid PixelFormats in the same way as for a typical 2D camera.

The main parts are

- **Coordinate system:** The 3D data may be expressed in Cartesian, Spherical or Cylindrical coordinates. It is also important where the coordinate system is located relative to the device.
- **Calibration:** The camera may be calibrated to a world coordinate system. The calibration can also include a rectification to a uniform sampling grid. Rectification can give 2.5D range images suitable for standard image processing.
- **Transformation:** The position and pose of the 3D data can be transformed to give output in a coordinate system relevant to the application.

Note that data may also be uncalibrated in which case information on coordinate system and location is meaningless. Therefore many features can be skipped in some cameras, or visible only in some cases depending on e.g. calibration mode.

21.2.1 Coordinate systems

The defined coordinate systems are right-hand oriented Cartesian (X,Y,Z), Spherical (Theta, Phi, Rho) and Cylindrical (Theta, Y,Rho). Rho is used throughout as coordinate and pixel plane for spherical and cylindrical "Radius" coordinate. The spherical coordinate system with Phi as azimuth, angle from X axis, and Theta as polar angle from Z axis, is used in SFNC. This is referred to as the physics system. The nominal "distance" coordinate is always the 3rd coordinate, Z or Rho.

To avoid naming conflicts the 3 coordinates are named A, B and C when representing a generic 3D coordinate system, with C as the "distance" coordinate. In some cases, like coordinate system transformation, only use of Cartesian coordinates is defined, and then X, Y, Z are used.

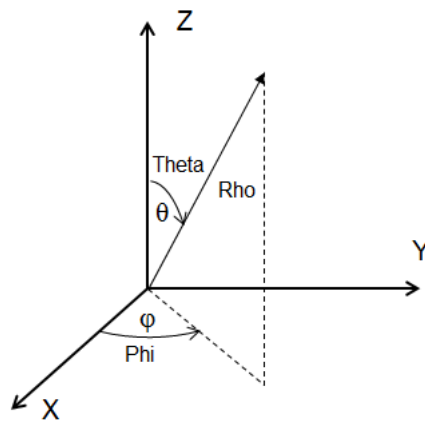

Figure 21-10: Relationship between Cartesian and Spherical coordinate systems.

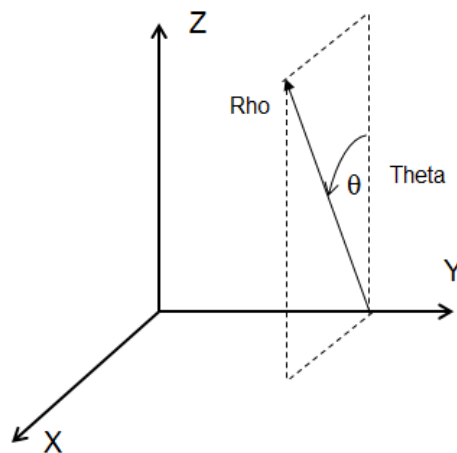

Figure 21-11: Relationship between Cartesian and Cylindrical coordinate systems.

Linescan 3D:

For Linescan 3D cameras data for each measurement is typically in the (X, Z) plane, and the motion direction is Y. This can then be transmitted as 2-component images (Coordinates A and C) with the 3rd coordinate (B) given by a common motion related coordinate which can be embedded as counter or encoder chunk information.

For a linescan3D camera with a native polar coordinate system Cylindrical 3D coordinates (Theta,Y,Rho) can be used. In some cases the measurement coordinate system is not aligned with the world coordinate system and full 3D representation for each point is needed.

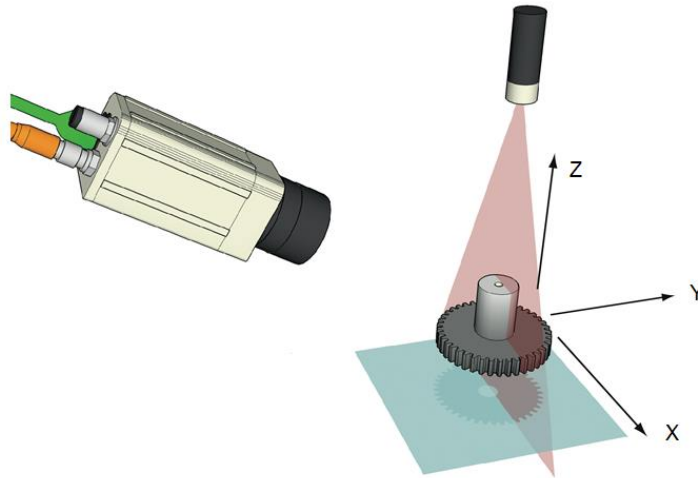

Figure 21-12: Typical orientation of the axes for a Linescan3D camera.

Coordinate dynamic range:

For 3D coordinates the dynamic range of the 3 coordinate axes defines a bounding box, within which all pixels are guaranteed to be. This can be used to limit the display of the data and to have suitable scaling. This is analogous with the `PixelDynamicRangeMin` and `PixelDynamicRangeMax` for intensity pixels.

The dynamic range is given in the transmitted coordinate units, i.e. before any scaling and/or offset calculation so that it reflects the actual values in the data stream.

21.2.2 Coordinate system position and transformation

Typically a 3D camera has a well-known pre-defined native **anchor** location and orientation of its measurement coordinate system. This is camera vendor specific and should if possible be defined in the camera documentation. Typical locations include the optical center of the camera, with the Z axis pointing away from the camera and a coordinate system defined to have a Z axis pointing towards the camera located to give only positive coordinates as illustrated in the figure below.

It is also recommended to place a reference point marker, with the distance (Z) pointing away from the device, on the device, and give the position and pose of the anchor system relative to this reference point in the documentation and as the anchor position/pose information in the SFNC features

`Scan3dCoordinateReferenceValue`. A possible reference point marker is show in the figure below. With a 2D symbol the origin and orientation of 2 axes can be visualized, and by the use of a right-hand oriented system the 3rd axis orientation is then also given. Given the anchor system definition and a reference point on the device it is possible to display a received 3D image correctly as "seen from the camera" independent of the actual coordinate system used.

To facilitate merging and aligning data from multiple devices a device may support transforming from the anchored coordinate system to a **transformed** location and pose (orientation). The use of this transformation, and its definition, is determined with standard features described below.

The transforms are defined in Cartesian coordinates only, and therefore use the X,Y,Z notation. The transform values define the transform from Anchor to Reference and from Transformed to Reference coordinate system.

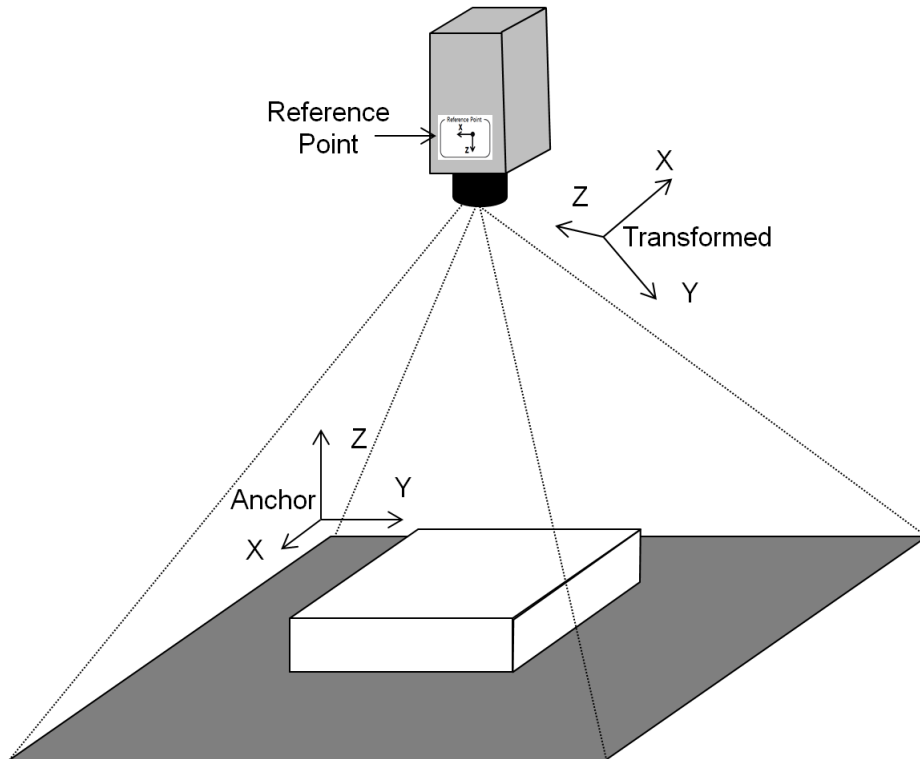

Figure 21-13: 3D camera anchors and transformed position and orientation.

Transform Definition:

The transformation from anchor to the transformed or reference coordinate system is defined by a rotation and then a translation to the new origin.

The transforms are ThX,ThY,ThZ – rotation angles around X,Y and Z axis, and a translation T to the new origin position. Thus, 3+3 = 6 parameters define the coordinate transform.

In homogenous coordinates the transform of a point from the original coordinate system to the transformed (i.e. from Anchor to Transformed for Scan3dTransformValue and Anchor /Transformed to Reference for Scan3dReferenceValue) is defined by the transforms

$$P = \begin{pmatrix} X \\ Y \\ Z \\ 1 \end{pmatrix}$$

$$P' = Trx * P, \quad Trx = \begin{pmatrix} 1 & 0 & 0 & 0 \\ 0 & \cos ThX & -\sin ThX & 0 \\ 0 & \sin ThX & \cos ThX & 0 \\ 0 & 0 & 0 & 1 \end{pmatrix}$$

$$P'' = Try * P', \quad Try = \begin{pmatrix} \cos ThY & 0 & \sin ThY & 0 \\ 0 & 1 & 0 & 0 \\ -\sin ThY & 0 & \cos ThY & 0 \\ 0 & 0 & 0 & 1 \end{pmatrix}$$

$$P''' = Trz * P'', \quad Trz = \begin{pmatrix} \cos ThZ & -\sin ThZ & 0 & 0 \\ \sin ThZ & \cos ThZ & 0 & 0 \\ 0 & 0 & 1 & 0 \\ 0 & 0 & 0 & 1 \end{pmatrix}$$

and finally

$$P'''' = Tt * P''', \quad Tt = \begin{pmatrix} 1 & 0 & 0 & TX \\ 0 & 1 & 0 & TY \\ 0 & 0 & 1 & TZ \\ 0 & 0 & 0 & 1 \end{pmatrix}$$

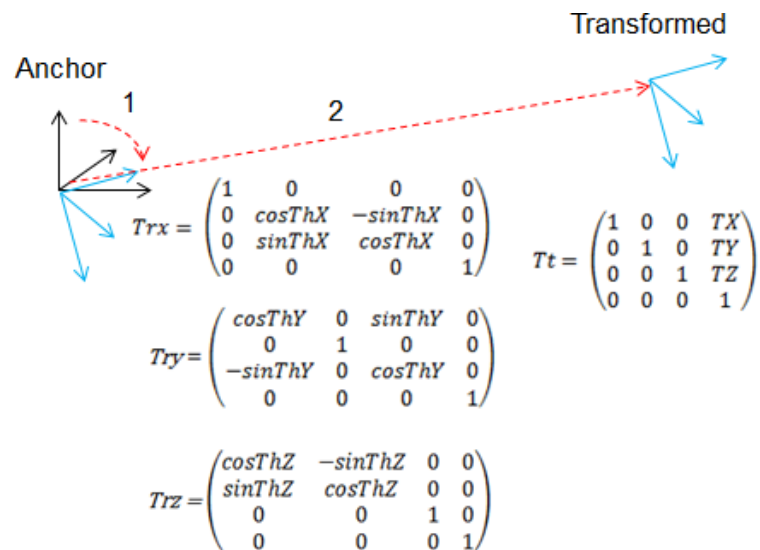

Figure 21-14: Transformation from the anchor to the transformed system.

Rectified Image data:

Calibrated 3D cameras typically generate "point-cloud" type data which does not have uniform sampling in the A-B dimension. This means that the Z, or range, image is impractical to use as a 2.5D range map with standard image processing since the apparent size of an object depends on the distance. If the point cloud is rectified to a uniform X-Y grid the Z image content will be a 2.5D range map where the apparent object size does not depend on the distance.

With rectified image data the offset to the first sample and the sample distance (scale) can be used to calculate the X and Y coordinate for any given sample in the image.

Rectified images are normally defined in Cartesian coordinates, since in other coordinate systems the apparent size of objects will be distance dependent even after rectification, but e.g. a laser scanner could have a native rectified polar coordinate system.

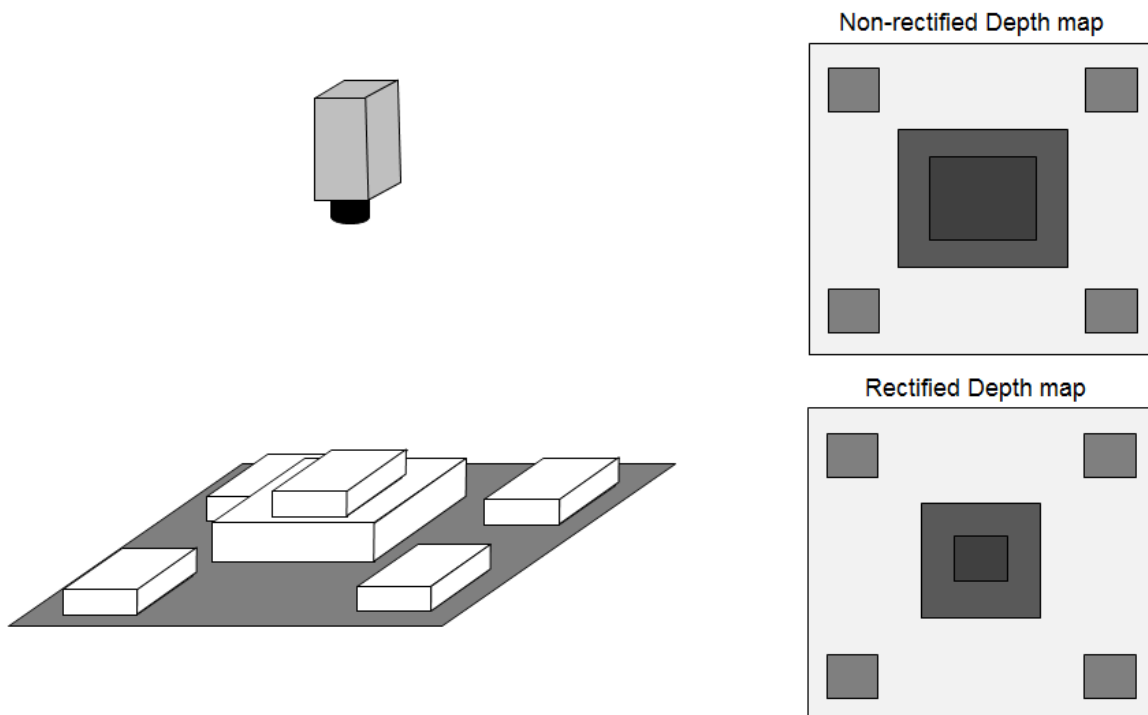
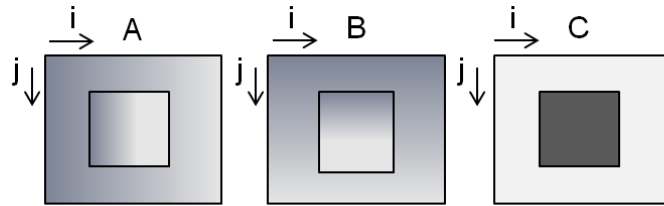

Figure 21-15: Rectified range maps (non-rectified range map image objects closer appear larger).



$$A(i,j)_{world} = A(i,j) * Scan3DCoordinateScale[C_A] + Scan3DCoordinateOffset[C_A]$$

$$B(i,j)_{world} = B(i,j) * Scan3DCoordinateScale[C_B] + Scan3DCoordinateOffset[C_B]$$

$$C(i,j)_{world} = C(i,j) * Scan3DCoordinateScale[C_C] + Scan3DCoordinateOffset[C_C]$$

Figure 21-16: Range image represented as 3 image planes, A,B,C.

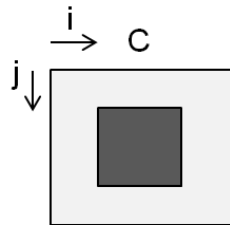

$$A(i,j)_{world} = i * Scan3DCoordinateScale[C_A] + Scan3DCoordinateOffset[C_A]$$

$$B(i,j)_{world} = j * Scan3DCoordinateScale[C_B] + Scan3DCoordinateOffset[C_B]$$

$$C(i,j)_{world} = C(i,j) * Scan3DCoordinateScale[C_C] + Scan3DCoordinateOffset[C_C]$$

Figure 21-17: Extraction of A,B and C world coordinate information in a rectified range map image C.

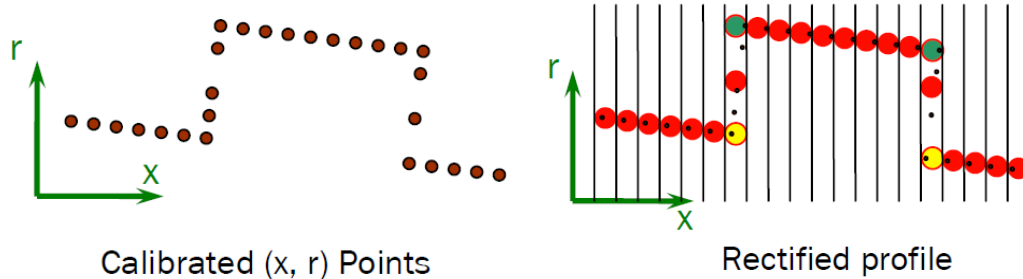

Figure 21-18: Point cloud rectified to uniform X sampling interval.

(Yellow/Green shows using min/max of multiple points in a bin, red average)

21.2.3 Focal length and Baseline for 3D Reconstruction from Disparity

The Disparity images contain the displacement of pixels in a stereo setup. The disparity of a pixel is directly linked to the distance of the pixel. The 3D reconstruction and calculation of a point cloud from disparity images is possible using parameters like the focal length and the baseline of the stereo camera.

Calculating World Coordinates from Disparity Images

A disparity image contains the displacement of corresponding pixels between the left and right images of a calibrated and rectified stereo image pair. The distance at a pixel is inversely proportional to the disparity at that pixel. A 3D point cloud can be calculated from a disparity image given additional parameters of the stereo camera, namely the focal length, baseline and image coordinates of the optical center.

The focal length in pixels (i.e. in units of the size of one image pixel after binning and decimation) is given in the feature `Scan3dFocalLength`. The baseline of the stereo system in the distance unit meter is given in the feature `Scan3dBaseline`. The optical axis of the camera is the line from the optical center of the camera that orthogonally intersects the image plane. The intersection point is referred to as principal point. This point is typically near the image center. Its horizontal and vertical location is given in the features `Scan3dPrincipalPointU` and `Scan3dPrincipalPointV`. These features refer to the selected region and are given relative to the `OffsetX` and `OffsetY` of that region.

These parameters of the calibrated stereo camera system permit the 3D reconstruction in the Cartesian camera coordinate system from the disparity $D(u,v)$ at pixel column u and row v :

$$X(u, v) = (u - \text{Scan3dPrincipalPointU}) * \text{Scan3dBaseline} / D(u, v)$$

$$Y(u, v) = (v - \text{Scan3dPrincipalPointV}) * \text{Scan3dBaseline} / D(u, v)$$

$$Z(u, v) = \text{Scan3dFocalLength} * \text{Scan3dBaseline} / D(u, v)$$

These equations permit the reconstruction of all pixels with valid disparities, resulting in a 3D point cloud. A disparity of 0 means that the point is at infinity. This case has to be treated specially when doing 3D reconstruction.

The pseudo code below shows how to compute a 3D point cloud from a disparity image. The algorithm also works if non-zero `OffsetX` and `OffsetY` are used to define a sub-region of the image. This is because `Scan3dPrincipalPointU` and `Scan3dPrincipalPointV`, like the column and row indices u and v , are relative to `OffsetX` and `OffsetY`. Therefore, no special treatment is necessary in this case.

```

Scan3dCoordinateSelector = CoordinateC
scaleC = Scan3dCoordinateScale[CoordinateC];
offsetC = Scan3dCoordinateOffset[CoordinateC];
isInvalidC = Scan3dInvalidDataFlag[CoordinateC];
invalidC = Scan3dInvalidDataValue[CoordinateC];

For (row = 0; row < Height; row++)
{
  for (col = 0; col < Width; col++)
  {
    C = imageC[row, col];

    if (isInvalidC == False || C != invalidC)
    {
      D = C*scaleC+offsetC;
      if (D > 0)
      {
        X = (col-Scan3dPrincipalPointU)*Scan3dBaseline/D;
        Y = (row-Scan3dPrincipalPointV)*Scan3dBaseline/D;
        Z = Scan3dFocalLength*Scan3dBaseline/D;
        // do something with the reconstructed point X, Y, Z
      }
    }
  }
}

```

```
    else
    {
        // point is reconstructed at infinity
    }
}
else
{
    // value is marked as invalid
}
}
}
```

21.3 3D Device data output control

A 3D extraction device typically have its sensor's data sent to a 3D extraction processing module to calculate information such as Range, Reflectance, etc. A sensor Region can optionally be used to limit the area of the sensor to process and the 3D extraction processing module also have a separate configurable output region to control the size and format of processed data to stream out. Most of the 3D extraction devices also have an option to directly stream out the raw sensor's 2D data for visualization during setup.

Linescan 3D device Regions and Components output

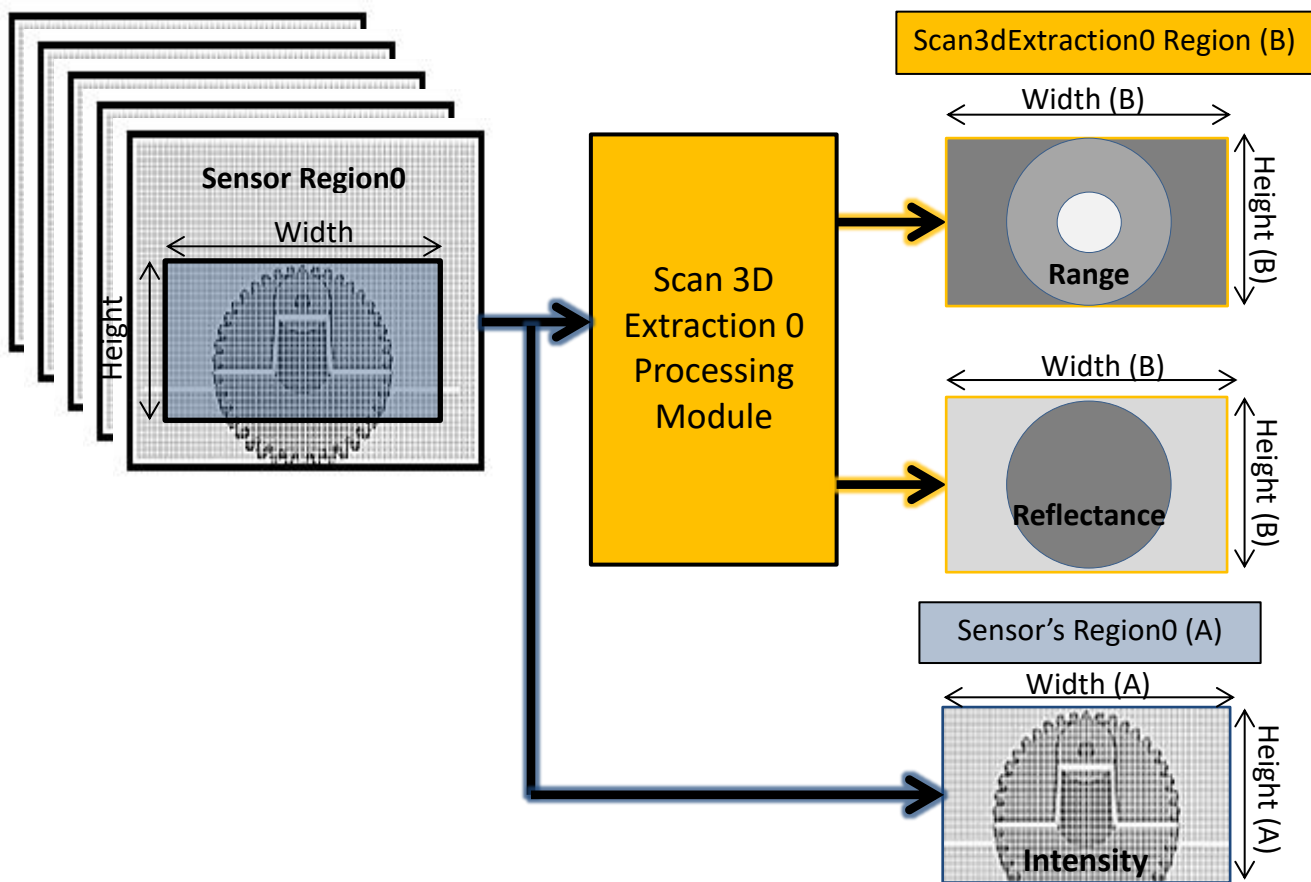

Figure 21-19: Linescan 3D device regions and components output control.

In the Figure 21-19 above, the 2D sensor's Region (A) of a Linescan 3D device is used to limit the area to analyse. A separate Scan 3D Extraction Region (B) defines the Width and Height of the 3D extraction output frame generated. The streaming of the Range, Reflectance or Intensity image components can be also enabled or disabled individually.

Note that in the scenario illustrated here and in the following examples, a Linescan 3D device is assumed. It is used to extract the range and reflectance of an object where a Laser line is projected. The object moves on a conveyer along the Y axis. With such a setup, during the scan of the object, each acquired 2D sensor image processed by the 3D Extraction module generates only one line of the 3D Range and Reflectance resulting frames. Therefore, Height (B) sensor images must be acquired before the full Range and Reflectance frames are complete.

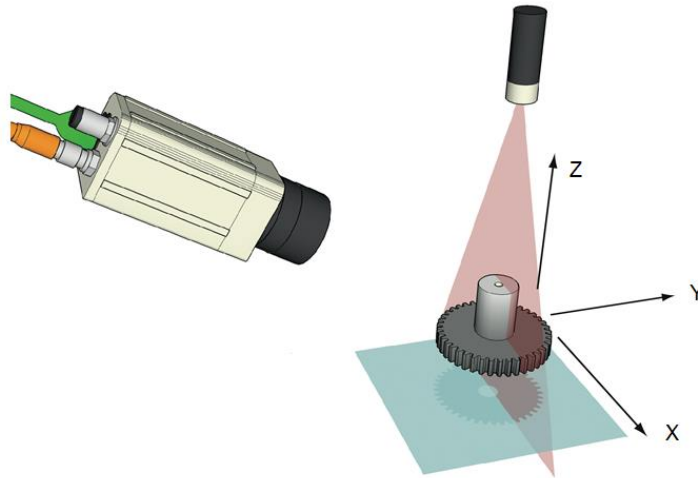

Figure 21-20: Typical Linescan 3D acquisition setup.

In general in an image acquisition device, the Height feature represents the number of lines in each output image. For Linescan cameras this feature is then not related to the sensor size but represents how many scan lines to include in each virtual frame generated. With 3D image extraction, there are use cases like for Linescan 3D device where an Areascan sensor is used in modes where the 3D scan processing result is similar to a regular Linescan sensor's device. In such Linescan 3D device, for each frame acquired by the sensor, the 3D extraction processing module will generate only one line of the resulting 3D image. So in those cases, the user needs to control individually the Height of the 2D sensor's Region to analyse and the Height of the resulting 3D processed buffer to transmit on the output stream.

To make possible to control both Height values independently using the existing Height feature, a combination of a sensor Region and dedicated 3D Scan Extraction processing module Region selectors can be used. The processing module Regions are optional formatters located at the output of the processing modules and that permit to control the dimensions and pixel format of the resulting image components.

In general, for a Region to deliver data to an output stream, its RegionMode must be On and at least one Component must be active. So with a combination of sensor's Region, processing module Region and the Component selectors, it is possible to stream out selectively the raw sensor data or the processed data output (or even both of them at the same time in certain cases).

21.3.1 3D Devices configuration use cases

The use cases below show different ways a Linescan 3D camera can be configured to output the 3D profile data, the image sensor raw data or both at the same time (See Figure 21-20 for the assumed setup).

Note that in a real 3D acquisition device, most of the feature configuration presented below can be done automatically by changing only the DeviceScanType feature from 3D to 2D. It is also highly recommended that, as far as possible, a read of Height feature without changing the region selector explicitly returns the height of the transmitted buffer.

In the followings examples, the state of the features after each example is used as the basis for the next one.

21.3.1.1 Linescan 3D Range and Reflectance output

In this use case, the Area sensor's Region0 defines the acquired sensor image dimension and is used as source to the Scan 3D Extraction processing module. A separate Scan3DExtraction0 processing module Region (B) is used to define independently the size of the result of the 3D laser line extraction to output.

Linescan 3D device Range and Reflectance output:

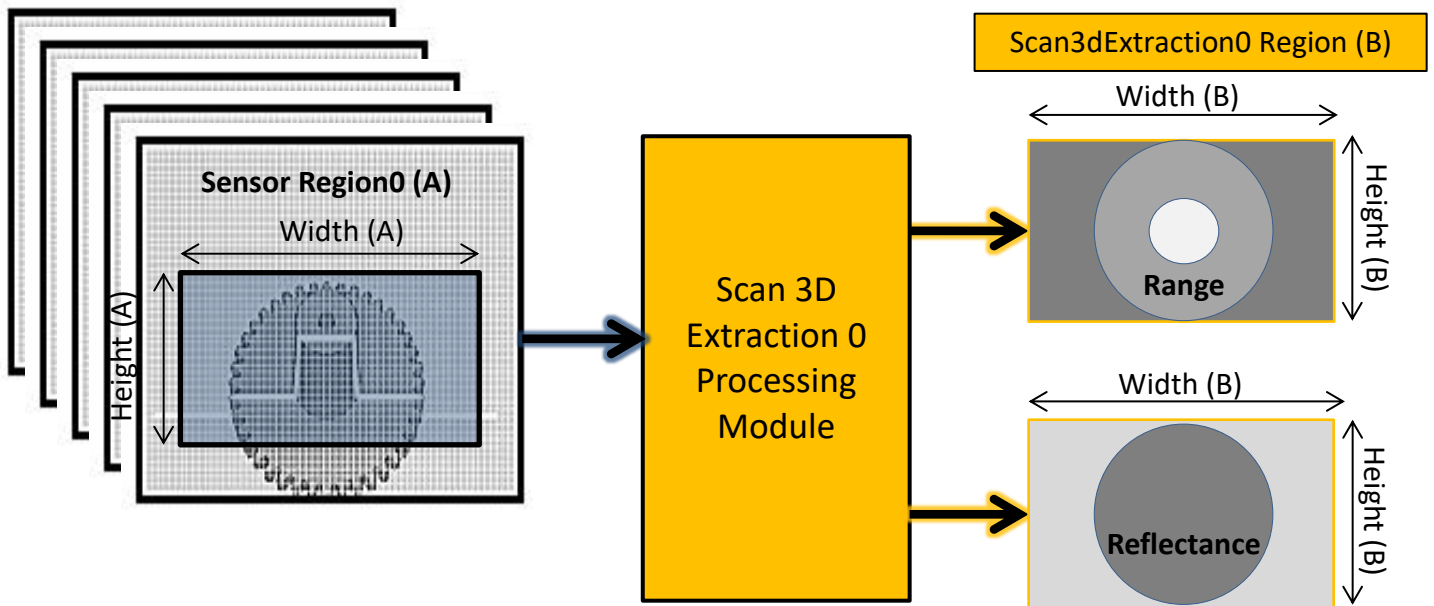

Figure 21-21: Linescan 3D Range and Reflectance components output.

```

// 1. DeviceScanType = Linescan3D.
// 3D profiling default mode (3D Range and Reflectance).
// *****
// Dataflow: Region0 -> Scan3dExtraction0 -> Stream0
// -----
// Region0:
//   Defines the size and position of the sensor's Region to process.
// -----
// Scan3dExtraction0:
//   Processing module that extracts a 3D line profile from the 2D data.
//   It's output Region defines the size of the processed buffer to send out.
// -----

// Sensor Region0.
RegionSelector      = Region0; // First Sensor Region.
Width[Region0]     = 800;      // Number of rows of the sensor to read.
Height[Region0]    = 500;      // Number of lines of the sensor to read.
OffsetX[Region0]   = 100;      // Position of Region0 on sensor.
OffsetY[Region0]   = 400;      // Position of Region0 on sensor.
RegionMode[Region0] = On;      // Region 0 features (Width, Height, ...) active.

// Disable Region0 Intensity output.
ComponentSelector   = Intensity;
ComponentEnable[Region0][Intensity] = False;

// Setup 3D Processing Module source and parameters.
Scan3dExtractionSelector = Scan3dExtraction0;
Scan3dExtractionSource[Scan3dExtraction0] = Region0;
Scan3dExtractionMethod[Scan3dExtraction0] = Default;

// Scan3dExtraction0 output Region (processed data output size).
RegionSelector      = Scan3dExtraction0; // First 3D Extraction output Region.
Width[Scan3dExtraction0] = 800;          // 3D Extraction output "frame Width".
Height[Scan3dExtraction0] = 640;         // 3D Extraction output "frame Height".
RegionMode[Scan3dExtraction0] = On;

// Enable Scan3dExtraction0 3D output (Range and Reflectance).
ComponentSelector   = Range;
ComponentEnable[Scan3dExtraction0][Range] = True;
ComponentSelector   = Reflectance;
ComponentEnable[Scan3dExtraction0][Reflectance] = True;

AquisitionStart;
...
AquisitionStop;

```

21.3.1.2 Linescan 3D sensor's Intensity output

Here the Intensity of the Area sensor's Region0 is streamed out. The Region0 (A) is used directly as 2D Intensity data source to stream out and the Scan 3D Extraction processing module output is disabled.

Linescan 3D device sensor Intensity output:

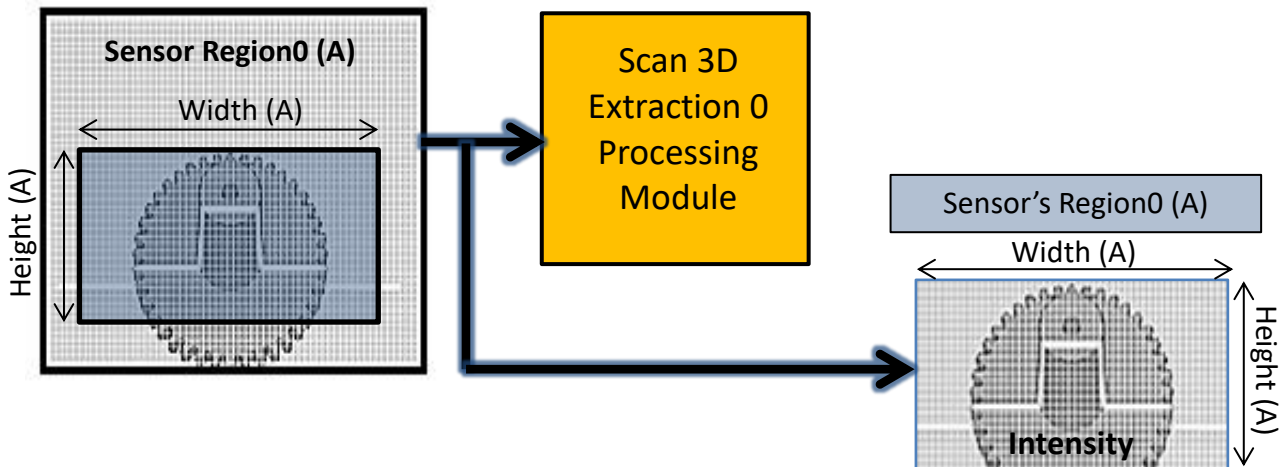

Figure 21-22: Linescan 3D sensor Intensity components output.

```
// 2. DeviceScanType = Areascan
// Switch to sensor 2D image output mode (Sensor Intensity out).
// -----
// Dataflow: Region0 -> Stream0

// Enable Region0 Intensity output.
RegionSelector           = Region0;
ComponentSelector       = Intensity;
ComponentEnable[Region0][Intensity] = True;

// Disable Scan3dExtraction0 3D output (Range and Reflectance).
RegionSelector          = Scan3dExtraction0;
RegionMode[Scan3dExtraction0] = Off; // Disable the Region output.

// Start and eventually Stop acquisition.
AquisitionStart;
...
// Stop acquisition.
AquisitionStop;
```

21.3.1.3 Linescan 3D Hybrid Range, Reflectance and Intensity output

Here we still stream out simultaneously the raw sensor 2D Intensity of the Region0 and the Scan 3D Extraction module resulting Range and Reflectance components. This "hybrid" mode makes tuning of the device parameters easier since both the image and its resulting extracted 3D profile can be visualized together. Note that since each 2D frame acquired by the sensor Region0 (A) only generates one line of 3D laser line extraction result (B), the Height of the Range and Reflectance components out must be set to 1.

Linescan 3D device Hybrid Range, Reflectance and Intensity output:

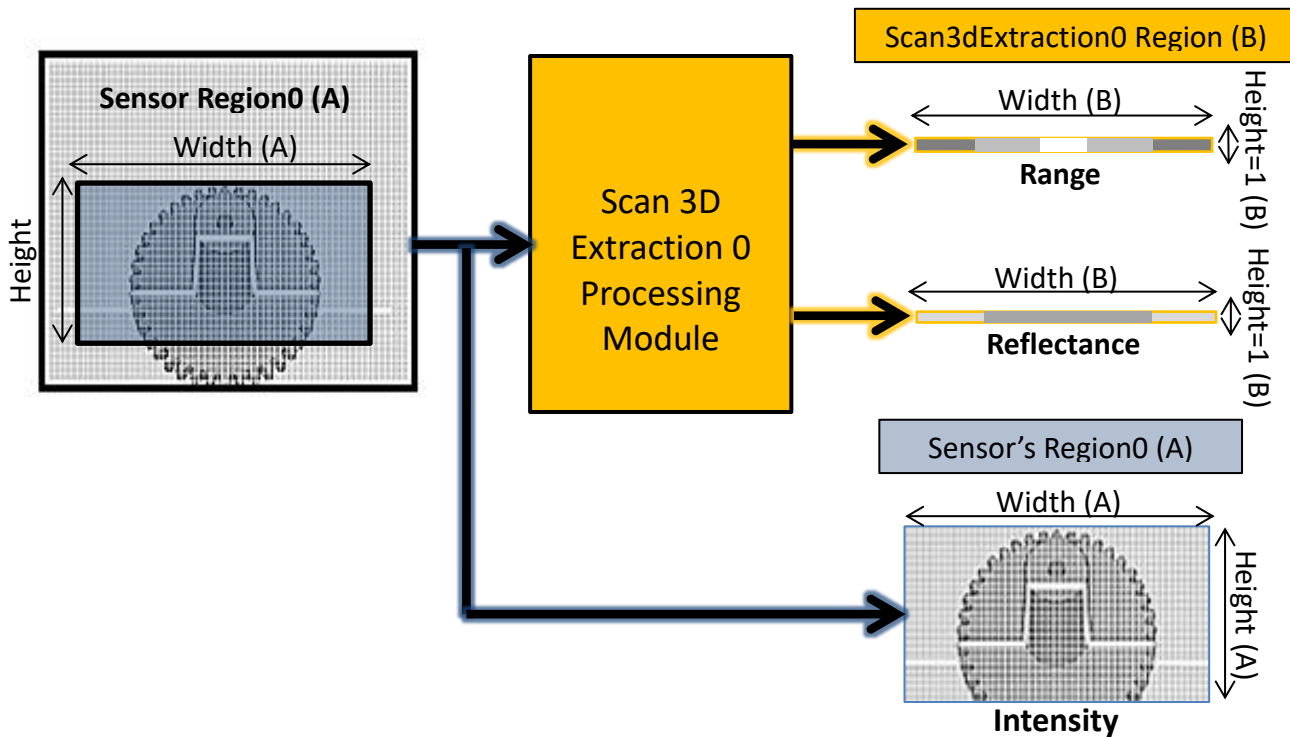

Figure 21-23: Linescan 3D Range and Reflectance components output.

```
// 3. Configuration Hybrid mode (2D sensor image and 3D profile)
// -----
// Dataflow: Region0 -> Stream0
//           Region0 -> Scan3dExtraction0 -> Stream0

// Sensor Intensity component output already enabled.
// Range and Reflectance components output already enabled.
// Set the 3D processing Region output size and enable it.
RegionSelector           = Scan3dExtraction0;
Height[Scan3dExtraction0] = 1; // 3D Extraction output "frame Height" = 1.
RegionMode[Scan3dExtraction0] = 0n; // Enable the region Output.

// Start and eventually Stop acquisition.
AquisitionStart;
...
AquisitionStop;
```

21.3.1.4 Linescan 3D Range output from 2 sensor regions

We will then do 2 simultaneous 3D Range extractions using 2 sensor Regions each sent to a separate Scan 3D Extraction processing module. Note that here, 2 separate laser lines are projected on the scanned object. See Figure 21-9 for an example of such a setup.

Linescan 3D device with dual Range

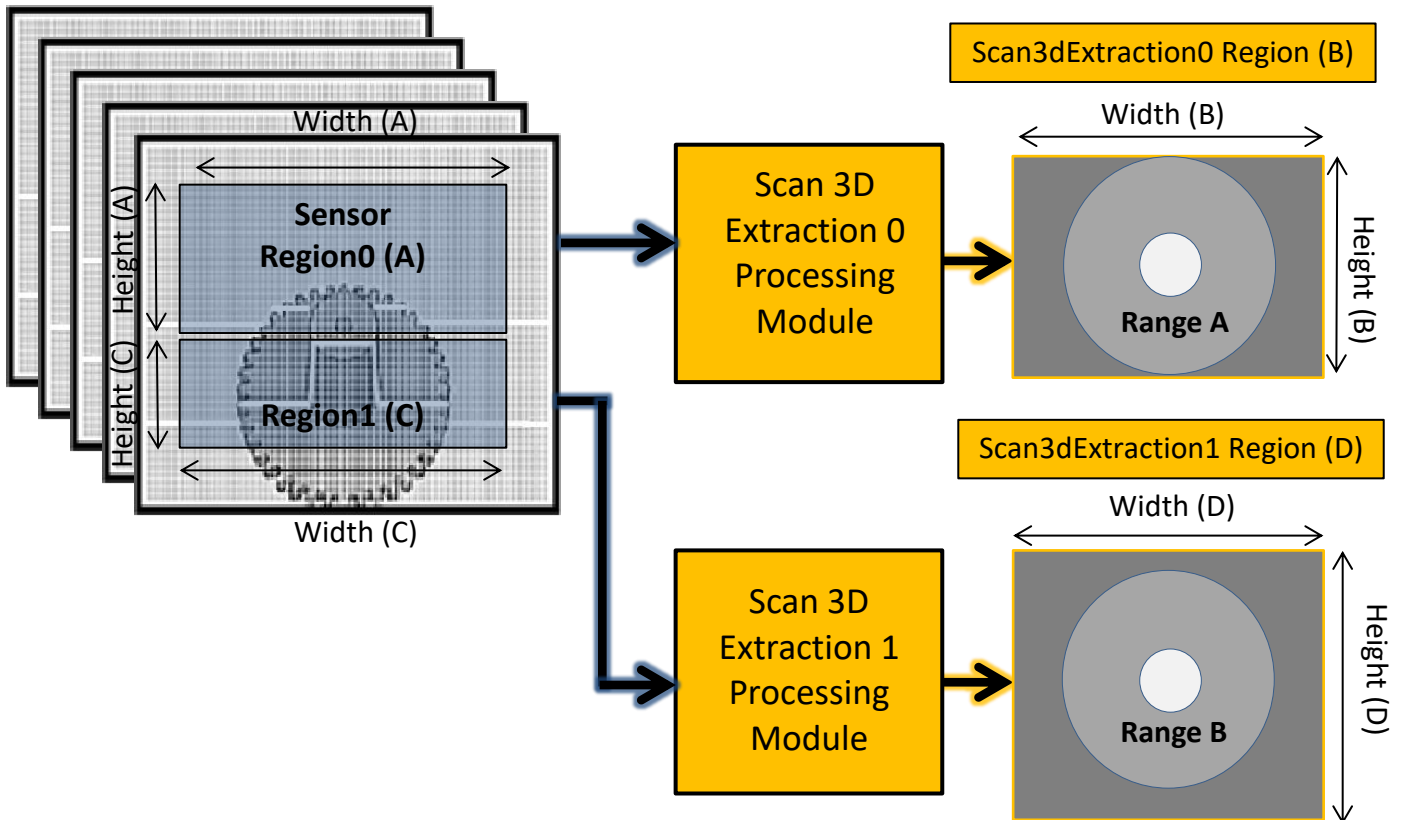

Figure 21-24: Linescan 3D with dual Range components output.

```
// Setup a 2 Regions to output 3D Range.
// -----
// Dataflow: Region0 -> Scan3dExtraction0 -> Stream0.
//           Region1 -> Scan3dExtraction1 -> Stream0.

// Set Region0 position and size.
RegionSelector      = Region0; // First Sensor Region.
OffsetX[Region0]   = 80;      // Position of Region on sensor.
OffsetY[Region0]   = 80;      // Position of Region on sensor.
Width[Region0]     = 800;     // Number of rows of the sensor to read.
Height[Region0]    = 400;     // Number of lines of the sensor to read.
RegionMode[Region0] = On;     // Region 0 features (Width, Height, ...) active.

// Disable Sensor's Region0 Intensity component output.
ComponentSelector  = Intensity;
```

```

ComponentEnable[Region0][Intensity] = False;

// Setup 3D Processing Module source and parameters.
Scan3dExtractionSelector           = Scan3dExtraction0;
Scan3dExtractionSource[Scan3dExtraction0] = Region0;
Scan3dExtractionMethod[Scan3dExtraction0] = Default;

// Scan3dExtraction0 output Region (processed data output size).
RegionSelector                     = Scan3dExtraction0; // First 3D Extraction output Region.
Width[Scan3dExtraction0]           = 800;               // 3D Extraction output "frame Width".
Height[Scan3dExtraction0]          = 640;               // 3D Extraction output "frame Height".
RegionMode[Scan3dExtraction0]     = On;

// Enable 3D Range output only.
ComponentSelector                   = Range;
ComponentEnable[Scan3dExtraction0][Range] = True;
ComponentSelector                   = Reflectance;
ComponentEnable[Scan3dExtraction0][Reflectance] = False;

// Set Region1 position and size.
RegionSelector                      = Region1; // Second Sensor Region.
OffsetX[Region1]                    = 80;     // Position of Region on sensor.
OffsetY[Region1]                    = 500;    // Position of Region on sensor.
Width[Region1]                      = 800;    // Number of rows of the sensor to read.
Height[Region1]                     = 300;    // Number of lines of the sensor to read.
RegionMode[Region1]                 = On;     // Region 1 features (Width, Height, ...) active.

// Disable Sensor's Region 1 Intensity component output.
ComponentSelector                    = Intensity;
ComponentEnable[Region1][Intensity] = False; // No Region1 Intensity out.

// Setup 3D Processing Module source and parameters.
Scan3dExtractionSelector             = Scan3dExtraction1;
Scan3dExtractionSource[Scan3dExtraction1] = Region1;
Scan3dExtractionMethod[Scan3dExtraction1] = Default;

// Scan3dExtraction1 output Region (processed data outputsize).
RegionSelector                       = Scan3dExtraction1; // Second 3D Extraction output Region.
Width[Scan3dExtraction1]             = 800;               // 3D Extraction output "frame Width".
Height[Scan3dExtraction1]            = 900;               // 3D Extraction output "frame Height".
RegionMode[Scan3dExtraction1]       = On;

// Enable 3D Range component output.
ComponentSelector                     = Range;
ComponentEnable[Scan3dExtraction1][Range] = True;
ComponentSelector                     = Reflectance;
ComponentEnable[Scan3dExtraction1][Reflectance] = False;

// Start Acquisition.
AquisitionStart;
...
AquisitionStop;

```

21.4 Scan 3D Features

This section defines the Scan 3D Control features.

21.4.1 Scan3dControl

Name	Scan3dControl
Category	Root
Level	Optional
Interface	ICategory
Access	Read
Unit	-
Visibility	Beginner
Values	-

Category for control of 3D camera specific features.

21.4.2 Scan3dExtractionSelector

Name	Scan3dExtractionSelector
Category	Scan3dControl
Level	Optional
Interface	IEnumeration
Access	Read/Write
Unit	-
Visibility	Expert
Values	Scan3dExtraction0 Scan3dExtraction1 ...

Selects the 3DExtraction processing module to control (if multiple ones are present).

Possible values are:

- Scan3dExtraction0: Selects Scan3d Extraction module 0.
- Scan3dExtraction1: Selects Scan3d Extraction module 1.
- ...

21.4.3 Scan3dExtractionSource

Name	Scan3dExtractionSource[Scan3dExtractionSelector]
Category	Scan3dControl
Level	Optional
Interface	IEnumeration
Access	Read/Write
Unit	-
Visibility	Expert
Values	Region0, Region1, ...

Selects the sensor’s data source region for 3D Extraction module.

Typically these are Sensor Regions, but it could also be another ProcessingModule.

Possible values are:

- **Region0**: Data come from Sensor’s Region0.
- **Region1**: Data come from Sensor’s Region1.
- ...

21.4.4 Scan3dExtractionMethod

Name	Scan3dExtractionMethod[Scan3dExtractionSelector]
Category	Scan3dControl
Level	Optional
Interface	IEnumeration
Access	Read/Write
Unit	-
Visibility	Expert
Values	Default Device-specific

Selects the method for extracting 3D from the input sensor data.

Typically device specific algorithms are used, and they can be either Line3D extracting (Linescan3D device) or Area3D extracting (Areascan3D device).

Possible values are:

- **Default:** Default range extraction method for the device.
- ...

Device specific values can be used to identify the various range extraction methods supported by the device.

21.4.5 Scan3dDistanceUnit

Name	Scan3dDistanceUnit[Scan3dExtractionSelector]
Category	Scan3dControl
Level	Optional
Interface	IEnumeration
Access	Read/(Write)
Unit	-
Visibility	Expert
Values	Millimeter Inch Pixel Device-specific

Specifies the unit used when delivering (calibrated) distance data.

Possible values are:

- **Millimeter:** Distance values are in millimeter units (default).
- **Inch:** Distance values are in inch units.
- **Pixel :** Distance values reflect pixel positions on the Sensor Array.

Device specific values can be used to indicate other meaning to distance data.

The angle unit used is degrees.

21.4.6 Scan3dCoordinateSystem

Name	Scan3dCoordinateSystem[Scan3dExtractionSelector]
Category	Scan3dControl
Level	Optional
Interface	IEnumeration

Access	Read/(Write)
Unit	-
Visibility	Expert
Values	Cartesian Spherical Cylindrical Device-specific

Specifies the Coordinate system to use for the device.

Note that the third coordinate, C, is the "distance" (Z or Rho) coordinates independent of the coordinate system used.

Possible values are:

- **Cartesian:** Default value. 3-axis orthogonal, right-hand X-Y-Z.
- **Spherical:** A Theta-Phi-Rho coordinate system.
- **Cylindrical:** A Theta-Y-Rho coordinate system.

In addition to the previous standard values, a device might also provide device-specific values (e.g. non-orthogonal coordinate system).

21.4.7 Scan3dOutputMode

Name	Scan3dOutputMode[Scan3dExtractionSelector]
Category	Scan3dControl
Level	Optional
Interface	IEnumeration
Access	Read/(Write)
Unit	-
Visibility	Expert
Values	UncalibratedC CalibratedABC_Grid CalibratedABC_PointCloud CalibratedAC CalibratedAC_Linescan CalibratedC CalibratedC_Linescan RectifiedC RectifiedC_Linescan DisparityC

DisparityC_Linescan

Controls the Calibration and data organization of the device and the coordinates transmitted.

Possible values are:

- **UncalibratedC:** Uncalibrated 2.5D Depth map. The distance data does not represent a physical unit and may be non-linear. The data is a 2.5D range map only.
- **CalibratedABC_Grid:** 3 Coordinates in grid organization. The full 3 coordinate data with the grid array organization from the sensor kept.
- **CalibratedABC_PointCloud:** 3 Coordinates without organization. The full 3 coordinate data without any organization of data points. Typically only valid points transmitted giving varying image size.
- **CalibratedAC:** 2 Coordinates with fixed B sampling. The data is sent as a A and C coordinates (X,Z or Theta,Rho). The B (Y) axis uses the scale and offset parameters for the B axis.
- **CalibratedAC_Linescan:** 2 Coordinates with varying sampling. The data is sent as a A and C coordinates (X,Z or Theta,Rho). The B (Y) axis comes from the encoder chunk value.
- **CalibratedC:** Calibrated 2.5D Depth map. The distance data is expressed in the chosen distance unit. The data is a 2.5D range map. No information on X-Y axes available.
- **CalibratedC_Linescan:** Depth Map with varying B sampling. The distance data is expressed in the chosen distance unit. The data is a 2.5D range map. The B (Y) axis comes from the encoder chunk value.
- **RectifiedC:** Rectified 2.5D Depth map. The distance data has been rectified to a uniform sampling pattern in the X and Y direction. The data is a 2.5D range map only. If a complete 3D point cloud is rectified but transmitted as explicit coordinates it should be transmitted as one of the "CalibratedABC" formats.
- **RectifiedC_Linescan:** Rectified 2.5D Depth map with varying B sampling. The data is sent as rectified 1D profiles using Coord3D_C pixels. The B (Y) axis comes from the encoder chunk value.
- **DisparityC:** Disparity 2.5D Depth map. The distance is inversely proportional to the pixel (disparity) value.
- **DisparityC_Linescan:** Disparity 2.5D Depth map with varying B sampling. The distance is inversely proportional to the pixel (disparity) value. The B (Y) axis comes from the encoder chunk value.

Scan3dOutputMode	3dScanType		PixelFormats	Comment
	Line	Area		
UncalibratedC	X	X	Coord3D_C	
CalibratedABC_Grid	X	X	Coord3D_ABC	Can be sent as 3 planar parts A/B/C.
CalibratedABC_PointCloud	X	X	Coord3D_ABC	Can be sent as 3 planar parts A/B/C.

CalibratedAC	X		Coord3D_AC	The B (scan direction) scaling from scale and offset data.
CalibratedAC_Linescan	X		Coord3D_AC	The B (scan direction) scaling is in Encoder Chunk data.
CalibratedC	X	X	Coord3D_C	Only calibrated range.
CalibratedC_Linescan	X		Coord3D_C	Only calibrated range. The B (scan direction) scaling is in Encoder Chunk data.
RectifiedC	X	X	Coord3D_C	Typically used together with Cartesian coordinate system.
RectifiedC_Linescan	X		Coord3D_C	The B (scan direction) scaling in Encoder Chunk data. Typically used together with Cartesian coordinate system.
DisparityC	X	X	Coord3D_C	
DisparityC_Linescan	X		Coord3D_C	The B (scan direction) scaling in Encoder Chunk data.

Linescan modes:

There are a number of linescan specific modes, i.e. with the suffix `_Linescan`. These use embedded chunk encoder information to specify the displacement between the lines in the 3D data stream. These modes are only applicable in situations where the encoder scaling is known and the encoder values transmitted as chunk data for each scan line.

If an encoder is used to trigger the camera at specific displacement intervals this displacement can be set as the scale, and a "non-linescan" mode can be used.

Use case Examples:

Here we illustrate the calculation of 3D world coordinates for the calibrated formats above.

In the following examples, consider the common definitions of scale and offset:

```
// CoordinateA - X/Theta.
ChunkScan3dCoordinateSelector = CoordinateA;
scaleA = ChunkScan3dCoordinateScale[CoordinateA];
offsetA = ChunkScan3dCoordinateOffset[CoordinateA];
// CoordinateB - Y / Phi
ChunkScan3dCoordinateSelector = CoordinateB;
scaleB = ChunkScan3dCoordinateScale[CoordinateB];
offsetB = ChunkScan3dCoordinateOffset[CoordinateB];
```

```
// CoordinateC - Z / Rho
ChunkScan3dCoordinateSelector = CoordinateC;
scaleC = ChunkScan3dCoordinateScale[CoordinateC];
offsetC = ChunkScan3dCoordinateOffset[CoordinateC];
```

Then, for each mode

CalibratedABC_Grid

The transmitted coordinates can be transformed to world coordinates using the following pseudo-code:

```
for(row = 0; row < Height; row++)
{
  for(col = 0; col < Width; col++)
  {
    coordA [row,col] = imageA [row,col]*scaleA+offsetA;
    coordB [row,col] = imageB [row,col]*scaleB+offsetB;
    coordC [row,col] = imageC [row,col]*scaleC+offsetC;
  }
}
```

CalibratedABC_PointCloud

In this format N pixel values in a vector are transmitted each frame. The transmitted coordinates can be transformed to world coordinates using the following pseudo-code:

```
for(i=1; i<N; i++)
{
  coordA [i] = imageA [i]*scaleA+offsetA;
  coordB [i] = imageB [i]*scaleB+offsetB;
  coordC [i] = imageC [i]*scaleC+offsetC;
}
```

CalibratedAC

The transmitted coordinates can be transformed to world coordinates using the following pseudo-code:

```
for(row = 0; row < Height; row++)
{
  for(col = 0; col < Width; col++)
  {
    coordA [row,col] = imageA [row,col]*scaleA+offsetA;
    coordB [row,col] = row*scaleB+offsetB;
    coordC [row,col] = imageC [row,col]*scaleC+offsetC;
  }
}
```

CalibratedAC_Linescan

The transmitted coordinates can be transformed to world coordinates using the following pseudo-code:

```
for(row = 0; row < Height; row++)
{
  for(col = 0; col < Width; col++)
  {
    coordA [row,col] = imageA [row,col]*scaleA+offsetA;
    ChunkScanLineSelector = row;
  }
}
```

```
// Note: Here encoder wrap-around handling is not illustrated.
coordB [row,col] = ChunkEncoderValue[row]*scaleB+offsetB;
coordC [row,col] = imageC [row,col]*scaleC+offsetC;
}
}
```

CalibratedC

The transmitted coordinates can be transformed to world coordinates using the following pseudo-code:

```
for(row = 0; row < Height; row++)
{
  for(col = 0; col < Width; col++)
  {
    coordC [row,col] = imageC [row,col]*scaleC+offsetC;
  }
}
```

CalibratedC_Linescan

The transmitted coordinates can be transformed to world coordinates using the following pseudo-code:

```
for(row = 0; row < Height; row++)
{
  for(col = 0; col < Width; col++)
  {
    ChunkScanLineSelector = row;
    // Note: Here encoder wrap-around handling is not illustrated.
    coordB [row,col] = ChunkEncoderValue[row]*scaleB+offsetB;
    coordC [row,col] = imageC [row,col]*scaleC+offsetC;
  }
}
```

RectifiedC

The transmitted coordinates can be transformed to world coordinates using the following pseudo-code:

```
for(row = 0; row < Height; row++)
{
  for(col = 0; col < Width; col++)
  {
    coordA [row,col] = col*scaleA+offsetA;
    coordB [row,col] = row*scaleB+offsetB;
    coordC [row,col] = imageC [row,col]*scaleC+offsetC;
  }
}
```

RectifiedC_Linescan

The transmitted coordinates can be transformed to world coordinates using the following pseudo-code:

```
for(row = 0; row < Height; row++)
{
  for(col = 0; col < Width; col++)
  {
    coordA [row,col] = col*scaleA+offsetA;
    ChunkScanLineSelector = row;
  }
}
```

```
// Note: Here encoder wrap-around handling is not illustrated.
coordB [row,col] = ChunkEncoderValue[row]*scaleB+offsetB;
coordC [row,col] = imageC [row,col]*scaleC+offsetC;
}
}
```

DisparityC

The transmitted disparity can be scaled and an offset added using the following pseudo-code (see Section 21.2.3 for 3D reconstruction):

```
for(row = 0; row < Height; row++)
{
  for(col = 0; col < Width; col++)
  {
    coordC [row,col] = imageC [row,col]*scaleC+offsetC;
  }
}
```

DisparityC_Linescan

The transmitted B (Y) coordinate can be transformed to world coordinates using the following pseudo-code:

```
for(row = 0; row < Height; row++)
{
  for(col = 0; col < Width; col++)
  {
    ChunkScanLineSelector = row;
    // Note: Here encoder wrap-around handling is not illustrated.
    coordB [row,col] = ChunkEncoderValue[row]*scaleB+offsetB;
    coordC [row,col] = imageC [row,col]*scaleC+offsetC; // Just scaling to e.g. pixel scale.
  }
}
```

21.4.8 Scan3dCoordinateSystemReference

Name	Scan3dCoordinateSystemReference[Scan3dExtractionSelector]
Category	Scan3dControl
Level	Optional
Interface	IEnumeration
Access	Read/Write
Unit	-
Visibility	Expert
Values	Anchor Transformed

Defines coordinate system reference location.

Defines if the fixed (Anchor) or floating (Transformed) coordinate system is used.

Possible values are:

- **Anchor:** Default value. Original fixed reference. The coordinate system fixed relative the camera reference point marker is used.
- **Transformed:** Transformed reference system. The transformed coordinate system is used according to the definition in the rotation and translation matrices.

21.4.9 Scan3dCoordinateSelector

Name	Scan3dCoordinateSelector[Scan3dExtractionSelector]
Category	Scan3dControl
Level	Optional
Interface	IEnumeration
Access	Read/Write
Unit	-
Visibility	Expert
Values	CoordinateA CoordinateB CoordinateC

Selects the individual coordinates in the vectors for 3D information/transformation.

This selector is used for all 3D vectors below, independent if they are position or angle coordinates.

Possible values are:

- **CoordinateA:** The first (X or Theta) coordinate
- **CoordinateB:** The second (Y or Phi) coordinate
- **CoordinateC:** The third (Z or Rho) coordinate.

An example using this to setup scaling and offset of a Cartesian data stream is given below.

```
// Get Scale & offset, for all 3 coordinates
Scan3dCoordinateSelector = CoordinateA; // CoordinateA - X
scaleA = Scan3dCoordinateScale[CoordinateA]; // e.g. 0.5
offsetA = Scan3dCoordinateOffset[CoordinateA]; // e.g. -500

Scan3dCoordinateSelector = CoordinateB; // CoordinateB - Y
scaleB = Scan3dCoordinateScale[CoordinateB]; // e.g.0.5
offsetB = Scan3dCoordinateOffset[CoordinateB]; // e.g. -500

// Negative scale & large offset to switch Z direction.
Scan3dCoordinateSelector = CoordinateC; // CoordinateC - Z
scaleC = Scan3dCoordinateScale[CoordinateA]; // e.g. -0.12
offsetC = Scan3dCoordinateOffset[CoordinateA]; // e.g. 5000
```

21.4.10 Scan3dCoordinateScale

Name	Scan3dCoordinateScale[Scan3dExtractionSelector][Scan3dCoordinateSelector]
Category	Scan3dControl
Level	Optional
Interface	IFloat
Access	Read/(Write)
Unit	-
Visibility	Expert
Values	-

Scale factor when transforming a pixel from relative coordinates to world coordinates. A negative scale mirrors the axis. For rectified image axes it is the distance between samples in the rectified image along this axis. See example below.

21.4.11 Scan3dCoordinateOffset

Name	Scan3dCoordinateOffset[Scan3dExtractionSelector][Scan3dCoordinateSelector]
Category	Scan3dControl
Level	Optional
Interface	IFloat
Access	Read/(Write)
Unit	-
Visibility	Expert
Values	-

Offset when transforming a pixel from relative coordinates to world coordinates.

Calibration scaling and offset:

The pseudo code shows how to read and use scale and offset in a full 3D calibrated image (scale and offset from chunk data as in examples above).

```

for(row = 0; row < Height; row++)
{
    for(col = 0; col < Width; col++)
    {
        coordA[row,col] = imageA[row,col]*scaleA+offsetA;
        coordB[row,col] = imageB[row,col]*scaleB+offsetB;
        coordC[row,col] = imageC[row,col]*scaleC+offsetC;
    }
}
    
```

```
    }
}
```

Rectification scaling and offset:

The pseudo code shows how to read and use scale and offset in a rectified image (scale and offset from chunk data as in examples above).

```
for(row = 0; row < Height; row++)
{
  for(col = 0; col < Width; col++)
  {
    coordA[row,col]= col*scaleA+offsetA;
    coordB[row,col] = row*scaleB+offsetB;
    coordC[row,col] = imageC[row,col]*scaleC+offsetC;
  }
}
```

21.4.12 Scan3dInvalidDataFlag

Name	Scan3dInvalidDataFlag[Scan3dExtractionSelector][Scan3dCoordinateSelector]
Category	Scan3dControl
Level	Optional
Interface	IBoolean
Access	Read/(Write)
Unit	-
Visibility	Expert
Values	True False

Enables the definition of a non-valid flag value in the data stream. Note that the confidence output is an alternate recommended way to identify non-valid pixels. Using an Scan3dInvalidDataValue may give processing penalties due to special handling.

Possible values are:

- **False:** Default value. No specific value identifies missing or invalid points.
- **True:** The Scan3dInvalidDataValue specifies a special non-valid value.

21.4.13 Scan3dInvalidDataValue

Name	Scan3dInvalidDataValue[Scan3dExtractionSelector][Scan3dCoordinateSelector]
Category	Scan3dControl
Level	Optional

Interface	IFloat
Access	Read/(Write)
Unit	-
Visibility	Expert
Values	-

Value which identifies a non-valid pixel if Scan3dInvalidDataFlag is enabled.

Typically the invalid data is flagged in one coordinate (*Z/Rho*) only, but it can be applied to each coordinate.

If the pixel format is integer the value must be mapped to (rounded to) an integer register in the device. Using a floating point NaN during pixel data processing might incur performance penalties, it might be desirable to avoid such values within pixel data whenever possible.

21.4.14 Scan3dAxisMin

Name	Scan3dAxisMin[Scan3dExtractionSelector][Scan3dCoordinateSelector]
Category	Scan3dControl
Level	Optional
Interface	IFloat
Access	Read
Unit	-
Visibility	Expert
Values	-

Minimum valid transmitted coordinate value of the selected Axis.

The values are for information purposes to e.g. facilitate scaling of display resolution.

21.4.15 Scan3dAxisMax

Name	Scan3dAxisMax[Scan3dExtractionSelector][Scan3dCoordinateSelector]
Category	Scan3dControl
Level	Optional
Interface	IFloat
Access	Read
Unit	-
Visibility	Expert
Values	-

Maximum valid transmitted coordinate value of the selected Axis.
 The values are for information purposes to e.g. facilitate scaling of display resolution.

21.4.16 Scan3dCoordinateTransformSelector

Name	Scan3dCoordinateTransformSelector[Scan3dExtractionSelector]
Category	Scan3dControl
Level	Optional
Interface	IEnumeration
Access	Read/Write
Unit	-
Visibility	Expert
Values	RotationX RotationY RotationZ TranslationX TranslationY TranslationZ

Sets the index to read/write a coordinate transform value.

The transform from Anchor to Transformed coordinate system should be implemented as described in section 21.2.2 (Coordinate system position and transformation).

Possible values are:

- **RotationX:** Rotation around X axis.
- **RotationY:** Rotation around Y axis.
- **RotationZ:** Rotation around Z axis.
- **TranslationX:** Translation along X axis.
- **TranslationY:** Translation along Y axis.
- **TranslationZ:** Translation along Z axis.

21.4.17 Scan3dTransformValue

Name	Scan3dTransformValue[Scan3dExtractionSelector][Scan3dCoordinateTransformSelector]
Category	Scan3dControl

Level	Optional
Interface	IFloat
Access	Read/Write
Unit	-
Visibility	Expert
Values	-

Specifies the transform value selected. For translations (Scan3dCoordinateTransformSelector = TranslationX/Y/Z) it is expressed in the distance unit of the system, for rotations (Scan3dCoordinateTransformSelector = RotationX/Y/Z) in degrees.

21.4.18 Scan3dCoordinateReferenceSelector

Name	Scan3dCoordinateReferenceSelector[Scan3dExtractionSelector]
Category	Scan3dControl
Level	Optional
Interface	IEnumeration
Access	Read/Write
Unit	-
Visibility	Expert
Values	RotationX RotationY RotationZ TranslationX TranslationY TranslationZ

Sets the index to read a coordinate system reference value defining the transform of a point from the current (Anchor or Transformed) system to the reference system.

The transformation from Anchor and Transformed to the Reference coordinate system should be implemented as described in section 21.2.2 (Coordinate system position and transformation).

Possible values are:

- **RotationX:** Rotation around X axis.
- **RotationY:** Rotation around Y axis.
- **RotationZ:** Rotation around Z axis.
- **TranslationX:** X axis translation.

- **TranslationY:** Y axis translation.
- **TranslationZ:** Z axis translation.

21.4.19 Scan3dCoordinateReferenceValue

Name	Scan3dCoordinateReferenceValue[Scan3dExtractionSelector] [Scan3dCoordinateReferenceSelector]
Category	Scan3dControl
Level	Optional
Interface	IFloat
Access	Read
Unit	-
Visibility	Expert
Values	-

Returns the reference value selected. Reads the value of a rotation or translation value for the current (Anchor or Transformed) coordinate system transformation to the Reference system.

21.4.20 Scan3dFocalLength

Name	Scan3dFocalLength[RegionSelector]
Category	Scan3dControl
Level	Optional
Interface	IFloat
Access	Read
Unit	Pixel
Visibility	Expert
Values	> 0

Returns the focal length of the camera in pixel. The focal length depends on the selected region. The value of this feature takes into account horizontal binning, decimation, or any other function changing the image resolution.

21.4.21 Scan3dBaseline

Name	Scan3dBaseline
Category	Scan3dControl
Level	Optional
Interface	IFloat
Access	Read
Unit	m
Visibility	Expert
Values	> 0

Returns the baseline as the physical distance of two cameras in a stereo camera setup. The value of this feature can be used for 3D reconstruction from disparity images. In this case, the unit of the 3D coordinates corresponds to the unit of the baseline.

21.4.22 Scan3dPrincipalPointU

Name	Scan3dPrincipalPointU[RegionSelector]
Category	Scan3dControl
Level	Optional
Interface	IFloat
Access	Read
Unit	Pixel
Visibility	Expert
Values	-

Returns the value of the horizontal position of the principal point, relative to the region origin, i.e. OffsetX. The value of this feature takes into account horizontal binning, decimation, or any other function changing the image resolution.

21.4.23 Scan3dPrincipalPointV

Name	Scan3dPrincipalPointV[RegionSelector]
Category	Scan3dControl
Level	Optional
Interface	IFloat
Access	Read
Unit	Pixel
Visibility	Expert
Values	-

Returns the value of the vertical position of the principal point, relative to the region origin, i.e. OffsetY. The value of this feature takes into account vertical binning, decimation, or any other function changing the image resolution.

22 Light Control

The Lighting Control chapter describes the model and features related to the control of Lighting.

These features can be applied to dedicated Lighting Controller or to Cameras with integrated lighting control features.

Also, regular features such as the ones defined in Digital I/O Control and Counter and Timer Control can be used for lighting control (to generate strobe pulses, handle external IOs pins). Those features are already used in many cameras for basic Lighting Control (Ex: The sensor Exposure signal can be sent to an external output line to control a strobe light).

22.1 Existing Timer features for Light Control

Many “Counter and Timer Control” features can be used to control Strobe pulse generation.

For example, for pulse with duration in Time unit, the “**Timer**” features should be used.

```

TimerSelector = Timer1;           // Select the Timer1.
TimerDelay[Timer1] = 20;         // Set the delay before the pulse starts to 20us.
TimerDuration[Timer1] = 500;     // Set the pulse duration to 500us.
TimerTriggerSource = Line8;      // Set external input Line 8 as Trigger source for the Timer1.
TimerTriggerActivation = RisingEdge; // Choose rising edge to trigger the Timer1.
LineSelector = Line1;           // Select the external output Line 1.
LineSource[Line1]=Timer1Active; // Put the Timer 1 output pulse its source.

```

“Counter” and “Rotary Decoder” features can also be used for discrete pulses counting or none time based pulse generation.

Note also that events can be generated and sent to the user for most possible state changes of the Timers and Counters.

For example:

```

EventSelector = Timer1End;       // Select Timer 1 End of active period event.
EventNotification[Timer1End] = On; // Enable the event callback to the user.

```

22.2 Light Control Features usage

Rating of the Light and Overdriving:

Normally lights have one of the following characteristics specified:

Current rating:	The current needed to illuminate the light at 100% brightness
Voltage rating:	The voltage needed to illuminate the light at 100% brightness

The current rating is generally more useful as it allows safe overdriving. Effectively these values give the maximum DC values for the light.

Once the rating is known, the light can be driven at any brightness from 0% to 100% of its rating.

Sometime, lights can also be overdriven. In this case, these rating values can be exceeded when the light is pulsed for a short time at more than its 100% value. This has huge benefits in machine vision as it can give more than 10 times brightness from the light in some cases. When overdriving, setting a proper minimal delay between 2 consecutive pulses is very important to prevent the light being damaged.

Most lighting controllers drive the light with a DC constant current. Some other controller type use use Pulse Width Modulation (PWM) to control the brightness of the light. When PWM is used, this is generally managed internally within the controller and is not a parameter that the user needs to control.

Lighting control scenarios:

A light can be controlled in a number of ways. Common ways are:

Static state

The light is On or Off and controlled statically. The main control parameter is the lighting controller brightness.

```
// Continuous current sent to the light.
LineSelector = Line1; // Select the external output Line 1.
LineSource[Line1] = LightController0; // Put the static UserOutput1 bit as its source.
LightControllerSelector = LightController0; // Select the Light Controller.
LightVoltageRating[LightController0] = 24.0; // Max Voltage the light supports.
LightBrightness[LightController0] = 100; // Normal 100 % brightness.
LightControllerSource[LightController0] = UserOutput1; // Put the static UserOutput1 bit as its source.
UserOutputSelector = UserOutput1; // Select a static User output bit.
UserOutputValue = True; // Put it On (or Off).
```

External Pulse

The light is controlled by the signal coming from an external digital input signal. The main configuration parameter is the brightness.

```
// A pulse received on an input pin is sent to the light (keeping the same pulse duration).
LightControllerSelector = LightController0; // Select the Light Controller.
LightControllerSource[LightController0] = Line8; // Put the input Line8 as source.
LightVoltageRating[LightController0] = 24.0; // Max Voltage the light supports in continuous.
LightBrightness[LightController0] = 100; // Normal 100 % Light brightness.
LineSelector = Line1; // Select the external output Line 1.
LineSource[Line1] = LightController0; // Put the Light controller 1 as its source.
```

Timed Pulse

The light is normally off. When a trigger is received the light waits for a delay then pulses for a defined time. The main configuration parameters are the brightness, delay before pulse and pulse width.

// A pulse sent to the light upon reception of a delayed trigger.

```

TimerSelector = Timer0;           // Select the Timer1.
TimerDelay[Timer0] = 20;         // Set the delay before the pulse starts to 20us.
TimerDuration[Timer0] = 200;    // Set the pulse duration to 200us.
TimerTriggerSource = Line8;     // Set external input Line 8 as Trigger source for the Timer1.
TimerTriggerActivation = RisingEdge; // Choose rising edge to trigger the Timer.
TimerTriggerArmDelay[Timer0] = 500; // Set the minimum delay before next pulse to 500us.
LightControllerSelector=LightController0; // Select the Light Controller.
LightControllerSource[LightController0] = Timer1Active; // Put the Timer Output as source.
LightVoltageRating[LightController0] = 24.0; // Max Voltage the light supports.
LightBrightness[LightController0] = 250; // Overdrive to 250 % brightness for a short period.
LineSelector = Line1;          // Select the external output Line 1.
LineSource[Line1]=LightController0; // Put the Light controller as its source.

```

Note that a dedicated Line can be hard-wired to a light controller (no setting required).

In the case of embedded lighting, the light controller would be connected directly to the device's embedded light (no setting required). The above features should still be present for information purpose but read only.

22.3 Light Control Features

22.3.1 LightControl

Name	LightControl
Category	Root
Level	Optional
Interface	ICategory
Access	Read
Unit	-
Visibility	Beginner
Values	-

Category containing the Lighting control features.

22.3.2 LightControllerSelector

Name	LightControllerSelector
Category	LightControl
Level	Optional
Interface	IEnumeration
Access	Read/Write
Unit	-
Visibility	Beginner
Values	LightController0 LightController1 LightController2 ...

Selects the Light Controller to configure.

22.3.3 LightControllerSource

Name	LightControllerSource[LightControllerSelector]
Category	LightControl

Level	Optional
Interface	IEnumeration
Access	Read/Write
Unit	-
Visibility	Beginner
Values	Line0, ... Timer0,... Counter0, ... UserOutput0,... ...

Selects the input source signal of the Light Controller.

22.3.4 LightCurrentRating

Name	LightCurrentRating[LightControllerSelector]
Category	LightControl
Level	Optional
Interface	IFloat
Access	Read/Write
Unit	Amp
Visibility	Beginner
Values	≥ 0

Set the current rating of the lighting output.

22.3.5 LightVoltageRating

Name	LightVoltageRating[LightControllerSelector]
Category	LightControl
Level	Optional
Interface	IFloat
Access	Read/Write
Unit	Volt

Visibility	Beginner
Values	≥ 0

Set the voltage rating of the lighting output.

22.3.6 LightBrightness

Name	LightBrightness[LightControllerSelector]
Category	LightControl
Level	Optional
Interface	IFloat
Access	Read/Write
Unit	Percent
Visibility	Beginner
Values	≥ 0

Set the brightness of the lighting output in percent. Can be greater than 100% for short overdrive period.

22.3.7 LightConnectionStatus

Name	LightConnectionStatus[LightControllerSelector]
Category	LightControl
Level	Optional
Interface	IEnumeration
Access	Read
Unit	-
Visibility	Beginner
Values	Sensing Ready NoConnect Error

Status of a light connected to the controller's output Line.

22.3.8 LightCurrentMeasured

Name	LightCurrentMeasured[LightControllerSelector]
-------------	---

Category	LightControl
Level	Optional
Interface	IFloat
Access	Read
Unit	Amp
Visibility	Beginner
Values	≥ 0

The measured current applied to the lighting.

22.3.9 LightVoltageMeasured

Name	LightVoltageMeasured[LightControllerSelector]
Category	LightControl
Level	Optional
Interface	IFloat
Access	Read
Unit	Volt
Visibility	Beginner
Values	≥ 0

The measured voltage applied to the lighting.

23 Chunk Data Control

Chunks are tagged blocks of data. The tags allow a chunk parser to dissect the data payload into its elements and to identify the content.

The length of the chunk data section varies depending on the number of activated chunks, but the user can always expect the chunk data section to fit within the maximum size of **PayloadSize**.

Regular Chunk data mapping:

With chunks disabled by setting **ChunkModeActive** to **False** the camera streams frames consisting only of the image.

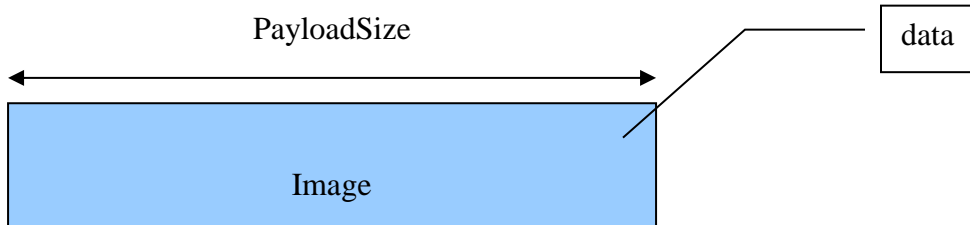

Figure 23-1: Frame with chunks disabled.

With chunks enabled by setting **ChunkModeActive** to **True** the camera streams frames consisting of chunks. In this mode the image is a chunk too.

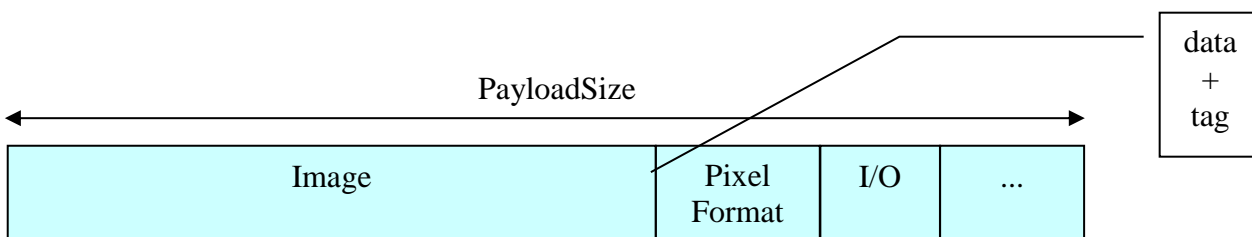

Figure 23-2: Frame with chunks enabled.

Each chunk can be enabled or disabled using the **ChunkSelector** and **ChunkEnable** feature. This allows controlling the embedding of different information in the payload.

The data in the chunks is exposed via the chunk parser. The naming scheme to access the data of the chunk *name* is **Chunkname**.

Multi-Component Chunk data mapping:

In general, a multi-component buffer is transmitted as a multi-part buffer where each Component maps to one or many parts.

For multi-part data on a single stream channel all image parts come before the chunk data transmitted as a separate part.

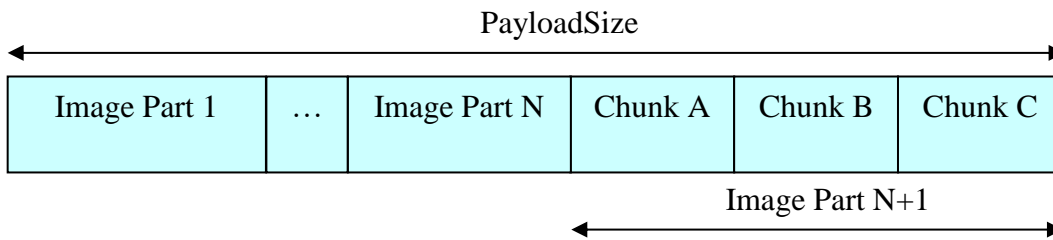

Figure 23-3: Illustration of multi-component/multi-Part data and chunks.

Selectors in Chunks

The Chunk Data Control defines a number of selectors that are available to access a particular item of a Chunk received. These selectors are not part of the transmitted chunk data, but are included in the device XML and can be used by the receiver to index the transmitted chunk data. Note that in the Chunk Data feature descriptions below it is not explicitly stated for all chunks whether they can be dependent on one or more selector, this information is device dependent and found in the XML for each selector.

These Chunk Data selectors include ChunkComponentSelector and ChunkScanLineSelector discussed in detail below, as well as other selectors such as the 3D specific chunk data.

A device potentially has multiple sources, where each source can have multiple regions and each region multiple components. A single multi-Component transfer contains data which from the system perspective belongs together and is expected to be processed together. This does not mean however that the chunk data is common to all Components.

Some chunk data can be applicable to Sources (possibly different sensor size), Regions (different image region size and offset and 3D configuration) or Components (different dynamic range and pixel formats).

Using these selectors it is possible to read and map chunk data to the individual Source, Region and Components.

For example to receive the Pixel Format information for each component of a 2 components image with chunk data and read it at the reception, the code could be:

Device side:

```

...
// Enable the Range and Confidence Components.
ComponentSelector = Range;
ComponentEnable   = True;
ComponentSelector = Confidence;
ComponentEnable   = True;

// Enable the Image and PixelFormat chunks.

```

```

ChunkModeActive = True;
ChunkSelector   = Image;
ChunkEnable     = True;
ChunkSelector   = PixelFormat;
ChunkEnable     = True;
    
```

```

// Start the acquisition of the multi-component buffer with its chunk data.
AcquisitionStart();
...
    
```

Reception side:

```

// At reception of a multi-component image, the component's pixel format are retrieved using:
ChunkComponentSelector = Range;
RangePixelFormat       = ChunkPixelFormat[Range];
ComponentSelector      = Confidence;
ConfidencePixelFormat  = ChunkPixelFormat[Confidence];
    
```

ChunkScanLineSelector:

Linescan cameras can have features that vary on per line basis. ExposureTime and EncoderValue are examples of such features that can vary from line to line. In order to handle properly those features in linescan mode, their value for each scan line must be included in the Chunk Data. ChunkScanLineSelector can then be used to retrieve each value in the received chunk.

Chunk Features description:

The chunk features are described below.

23.1 ChunkDataControl

Name	ChunkDataControl
Category	Root
Level	Recommended
Interface	ICategory
Access	Read
Unit	-
Visibility	Expert
Values	-

Category that contains the Chunk Data control features.

23.2 ChunkModeActive

Name	ChunkModeActive
-------------	-----------------

Category	ChunkDataControl
Level	Recommended
Interface	IBoolean
Access	Read/Write
Unit	-
Visibility	Expert
Values	True False

Activates the inclusion of Chunk data in the payload of the image.

23.3 ChunkSelector

Name	ChunkSelector
Category	ChunkDataControl
Level	Recommended
Interface	IEnumeration
Access	Read/Write
Unit	-
Visibility	Expert
Values	Image OffsetX OffsetY Width Height PixelFormat PixelDynamicRangeMax PixelDynamicRangeMin Timestamp TimestampLatchValue LineStatusAll CounterValue TimerValue EncoderValue EncoderStatusValue ExposureTime Gain BlackLevel

	LinePitch FrameID SourceID SourceIDValue RegionID RegionIDValue ComponentID ComponentIDValue TransferBlockID TransferStreamID TransferQueueCurrentBlockCount StreamChannelID SequencerSetActive Scan3dDistanceUnit Scan3dOutputMode Scan3dCoordinateSystem Scan3dCoordinateSystemReference Scan3dCoordinateScale Scan3dCoordinateOffset Scan3dInvalidDataFlag Scan3dInvalidDataValue Scan3dAxisMin Scan3dAxisMax Scan3dCoordinateTransformValue Scan3dCoordinateReferenceValue
--	--

Selects which Chunk to enable or control.

23.4 ChunkEnable

Name	ChunkEnable[ChunkSelector]
Category	ChunkDataControl
Level	Recommended
Interface	IBoolean
Access	Read/Write
Unit	-
Visibility	Expert
Values	True False

Enables the inclusion of the selected Chunk data in the payload of the image.

23.5 ChunkRegionSelector

Name	ChunkRegionSelector
Category	ChunkDataControl
Level	Optional
Interface	IEnumeration
Access	Read/Write
Unit	-
Visibility	Expert
Values	Region0 (if 0 based) Region1 Region2 ... Scan3dExtraction0 (if 0 based) Scan3dExtraction1 Scan3dExtraction2 ...

Selects which Region to retrieve data from.

This generally maps to the corresponding RegionSelector feature.

Note that if multiple Regions of interest are supported by the device, the **ChunkRegionSelector** can be added to various features such as ChunkWidth, ChunkHeight... to specify the behavior of the selected Region. In order to simplify the standard text and feature descriptions, the optional **ChunkRegionSelector** is not propagated to all the features of the SFNC that it can potentially select.

Possible values are:

- **Region0**: Image comes from the Region 0.
- **Region1**: Image comes from the Region 1.
- **Region2**: Image comes from the Region 2.
- ...
- **Scan3dExtraction0**: Image comes from the Scan3dExtraction output Region 0.
- **Scan3dExtraction1**: Image comes from the Scan3dExtraction output Region 1.
- **Scan3dExtraction2**: Image comes from the Scan3dExtraction output Region 2.
- ...

23.6 ChunkRegionID

Name	ChunkRegionID
Category	ChunkDataControl
Level	Optional
Interface	IEnumeration
Access	Read
Unit	-
Visibility	Expert
Values	Region0 (if 0 based) Region1 Region2 ... Scan3dExtraction0 (if 0 based) Scan3dExtraction1 Scan3dExtraction2 ...

Returns the Identifier of Region that the image comes from.

This generally maps to the corresponding RegionSelector feature.

Possible values are:

- **Region0**: Image comes from the Region 0.
- **Region1**: Image comes from the Region 1.
- **Region2**: Image comes from the Region 2.
- ...
- **Scan3dExtraction0**: Image comes from the Scan3dExtraction output Region 0.
- **Scan3dExtraction1**: Image comes from the Scan3dExtraction output Region 1.
- **Scan3dExtraction2**: Image comes from the Scan3dExtraction output Region 2.
- ...

23.7 ChunkRegionIDValue

Name	ChunkRegionIDValue[ChunkRegionSelector]
Category	ChunkDataControl
Level	Recommended

Interface	Integer
Access	Read
Unit	-
Visibility	Expert
Values	≥ 0

Returns the unique integer Identifier value of the Region that the image comes from.
 This generally maps to the corresponding RegionIDValue feature.

23.8 ChunkComponentSelector

Name	ChunkComponentSelector
Category	ChunkDataControl
Level	Optional
Interface	IEnumeration
Access	Read/Write
Unit	-
Visibility	Expert
Values	Intensity Infrared Ultraviolet Range Reflectance Disparity Confidence Scatter Device-specific

Selects the Component from which to retrieve data from.
 This generally maps to the corresponding ComponentSelector feature.
 Possible values are:

- **Intensity:** The image data is the intensity component (visible).
- **Infrared:** The image data is the infrared component.
- **Ultraviolet:** The image data is the ultraviolet component.

- **Range:** The image data is the range component (distance or depth).
- **Reflectance:** The image data is the reflected intensity component (acquired with the Range).
- **Disparity:** The image data is the disparity component.
- **Confidence:** The image data is the confidence map component.
- **Scatter:** The image data is the scatter component.

23.9 ChunkComponentID

Name	ChunkComponentID
Category	ChunkDataControl
Level	Optional
Interface	IEnumeration
Access	Read
Unit	-
Visibility	Expert
Values	Intensity Infrared Ultraviolet Range Reflectance Disparity Confidence Scatter Device-specific

Returns the Component Identifier of the selected Component image. This can be used to identify the image component type of a multi-component buffer.

For example, the Intensity and Scatter Components of a multi Components data buffer may be of the same pixel format and impossible to distinguish without this information.

This generally maps to the corresponding ComponentSelector feature.

Possible values are:

- **Intensity:** The image data is the intensity component (visible).
- **Infrared:** The image data is the infrared component.
- **Ultraviolet:** The image data is the ultraviolet component.

- **Range:** The image data is the range component (distance or depth).
- **Reflectance:** The image data is the reflected intensity component (acquired with the Range).
- **Disparity:** The image data is the disparity component.
- **Confidence:** The image data is the confidence map component.
- **Scatter:** The image data is the scatter component.

23.10 ChunkComponentIDValue

Name	ChunkComponentIDValue[ChunkComponentSelector]
Category	ImageFormatControl
Level	Optional
Interface	IInteger
Access	Read
Unit	-
Visibility	Expert
Values	≥ 0

Returns a unique Identifier value that correspond to the selected chunk Component.

This value generally maps to corresponding ComponentIDValue feature value.

23.11 ChunkImageComponent (Deprecated)

Name	ChunkImageComponent
Category	ChunkDataControl
Level	Optional
Interface	IEnumeration
Access	Read
Unit	-
Visibility	Invisible
Values	Intensity Infrared Ultraviolet Range Reflectance Disparity

	Confidence Scatter Device-specific
--	--

This feature is deprecated (See **ChunkComponentID**). It was representing the Component of the payload image.

To help backward compatibility, this feature can be included as Invisible in the device's XML.

23.12 ChunkPartSelector (Deprecated)

Name	ChunkPartSelector
Category	ChunkDataControl
Level	Optional
Interface	IInteger
Access	Read/Write
Unit	-
Visibility	Invisible
Values	≥0

This feature is deprecated (See **ChunkComponentSelector**). It was selecting the individual parts of a multi-component/multi-part buffer to access.

To help backward compatibility, this feature can be included as Invisible in the device's XML .

23.13 ChunkImage

Name	ChunkImage
Category	ChunkDataControl
Level	Recommended
Interface	IRegister
Access	Read
Unit	-
Visibility	Guru
Values	Device-specific

Returns the entire image data included in the payload.

23.14 ChunkOffsetX

Name	ChunkOffsetX
Category	ChunkDataControl
Level	Recommended
Interface	IInteger
Access	Read
Unit	-
Visibility	Expert
Values	≥ 0

Returns the **OffsetX** of the image included in the payload.

23.15 ChunkOffsetY

Name	ChunkOffsetY
Category	ChunkDataControl
Level	Recommended
Interface	IInteger
Access	Read
Unit	-
Visibility	Expert
Values	≥ 0

Returns the **OffsetY** of the image included in the payload.

23.16 ChunkWidth

Name	ChunkWidth[ChunkRegionSelector]
Category	ChunkDataControl
Level	Recommended
Interface	IInteger
Access	Read
Unit	-
Visibility	Expert

Values	>0
---------------	----

Returns the **Width** of the image included in the payload.

23.17 ChunkHeight

Name	ChunkHeight[ChunkRegionSelector]
Category	ChunkDataControl
Level	Recommended
Interface	IInteger
Access	Read
Unit	-
Visibility	Expert
Values	>0

Returns the **Height** of the image included in the payload.

23.18 ChunkPixelFormat

Name	ChunkPixelFormat
Category	ChunkDataControl
Level	Recommended
Interface	IEnumeration
Access	Read
Unit	-
Visibility	Expert
Values	Mono1p Mono2p Mono4p Mono8 Mono8s Mono10 Mono10p Mono12 Mono12p Mono14 Mono16

R8
G8
B8

RGB8
RGB8_Planar
RGBa8
RGB10
RGB10_Planar
RGB10p32
RGB12
RGB12_Planar
RGB16
RGB16_Planar
RGB565p

BGR10
BGR12
BGR16
BGR565p
BGR8
BGRa8

YUV422_8

YCbCr411_8
YCbCr422_8
YCbCr601_422_8
YCbCr709_422_8
YCbCr8

BayerBG8
BayerGB8
BayerGR8
BayerRG8
BayerBG10
BayerGB10
BayerGR10
BayerRG10
BayerBG12
BayerGB12
BayerGR12
BayerRG12

BayerBG16
 BayerGB16
 BayerGR16
 BayerRG16

 Coord3D_A8
 Coord3D_B8
 Coord3D_C8
 Coord3D_ABC8
 Coord3D_ABC8_Planar
 Coord3D_A16
 Coord3D_B16
 Coord3D_C16
 Coord3D_ABC16
 Coord3D_ABC16_Planar
 Coord3D_A32f
 Coord3D_B32f
 Coord3D_C32f
 Coord3D_ABC32f
 Coord3D_ABC32f_Planar
 Confidence1
 Confidence1p
 Confidence8
 Confidence16
 Confidence32f

 Raw8
 Raw16

 Device-specific

 - GigE Vision Specific:

 Mono12Packed
 BayerGR10Packed
 BayerRG10Packed
 BayerGB10Packed
 BayerBG10Packed
 BayerGR12Packed
 BayerRG12Packed
 BayerGB12Packed
 BayerBG12Packed
 RGB10V1Packed
 RGB12V1Packed

- Deprecated:

Mono8Signed (Deprecated, use Mono8s)
 RGB8Packed (Deprecated, use RGB8)
 BGR8Packed (Deprecated, use BGR8)
 RGBA8Packed (Deprecated, use RGBa8)
 BGRA8Packed (Deprecated, use BGRa8)
 RGB10Packed (Deprecated, use RGB10)
 BGR10Packed (Deprecated, use BGR10)
 RGB12Packed (Deprecated, use RGB12)
 BGR12Packed (Deprecated, use BGR12)
 RGB16Packed (Deprecated, use RGB16)
 BGR16Packed (Deprecated, use BGR16)
 RGB10V2Packed (Deprecated, use
 RGB10p32)
 BGR10V2Packed (Deprecated, use
 BGR10p32)
 RGB565Packed (Deprecated, use RGB565p)
 BGR565Packed (Deprecated, use BGR565p)
 YUV411Packed (Deprecated, use
 YUV411_8_UYYVYY)
 YUV422Packed (Deprecated, use
 YUV422_8_UYVY)
 YUV444Packed (Deprecated, use
 YUV8_UYV)
 YUYVPacked (Deprecated, use YUV422_8)
 RGB8Planar (Deprecated, use
 RGB8_Planar)
 RGB10Planar (Deprecated, use
 RGB10_Planar)
 RGB12Planar (Deprecated, use
 RGB12_Planar)
 RGB16Planar (Deprecated, use
 RGB16_Planar)

Returns the **PixelFormat** of the image included in the payload.

Possible values are:

- **Mono1p**: Mono 1 bit packed.
- **Mono2p**: Mono 2 bit packed.
- **Mono4p**: Mono 4 bit packed.
- **Mono8**: Mono 8 bit packed.

- **Mono8s**: Mono 1 bit signed.
- **Mono10**: Mono 10 bit.
- **Mono10p**: Mono 10 bit packed.
- **Mono12**: Mono 12 bit.
- **Mono12p**: Mono 12 bit packed.
- **Mono14**: Mono 14 bit.
- **Mono16**: Mono 16 bit.
- **R8**: Red 8 bit.
- **G8**: Green 8 bit.
- **B8**: Blue 8 bit.
- **RGB8**: Red, Green, Blue 8 bit
- **RGB8_Planar**: Red, Green, Blue 8 bit planar.
- **RGBa8**: Red, Green, Blue 8 bit aligned on 8 bit
- **RGB10**: Red, Green, Blue 10 bit.
- **RGB10_Planar**: Red, Green, Blue 10 bit planar.
- **RGB10p32**: Red, Green, Blue 10 bit packed in 32 bit pixel.
- **RGB12**: Red, Green, Blue 12 bit.
- **RGB12_Planar**: Red, Green, Blue 12 bit planar.
- **RGB16**: Red, Green, Blue 16 bit.
- **RGB16_Planar**: Red, Green, Blue 16 bit planar.
- **RGB565p**: Red, Green, Blue 16 bit packet in 5, 6, 5 bits.
- **BGR10**: Blue, Green, Red, 10 bit.
- **BGR12**: Blue, Green, Red, 12 bit.
- **BGR16**: Blue, Green, Red, 16 bit.
- **BGR565p**: Blue, Green, Red, 16 bit packet in 5, 6, 5 bits.
- **BGR8**: Blue, Green, Red, 8 bit.
- **BGRa8**: Blue, Green, Red, Alpha 8 bit.
- **YUV422_8**: YUV 422 8 bit.
- **YCbCr411_8**: YCrCb 411 8 bit.
- **YCbCr422_8**: YCrCb 422 8 bit.

- **YCbCr601_422_8:** YCrCb 601 422 8 bit.
- **YCbCr709_422_8:** YCrCb 709 422 8 bit.
- **YCbCr8:** YCbCr 8 bit.
- **BayerBG8:** Bayer Blue Green 8 bit.
- **BayerGB8:** Bayer Green Blue 8 bit.
- **BayerGR8:** Bayer Green Red 8 bit.
- **BayerRG8:** Bayer Red Green 8 bit.
- **BayerBG10:** Bayer Blue Green 10 bit.
- **BayerGB10:** Bayer Green Blue 10 bit.
- **BayerGR10:** Bayer Green Red 10 bit.
- **BayerRG10:** Bayer Red Green 10 bit.
- **BayerBG12:** Bayer Blue Green 12 bit
- **BayerGB12:** Bayer Green Blue 12 bit
- **BayerGR12:** Bayer Green Red 12 bit.
- **BayerRG12:** Bayer Red Green 12 bit.
- **BayerBG16:** Bayer Blue Green 16 bit.
- **BayerGB16:** Bayer Green Blue 16 bit.
- **BayerGR16:** Bayer Green Red 16 bit.
- **BayerRG16:** Bayer Red Green 16 bit.
- **Coord3D_A8:** 3D coordinate, first component 8 bit.
- **Coord3D_B8:** 3D coordinate, second component 8 bit.
- **Coord3D_C8:** 3D coordinate, third component 8 bit.
- **Coord3D_ABC8:** 3D coordinates, 3 components 8 bit.
- **Coord3D_ABC8_Planar:** 3D coordinates, 3 components 8 bit planar.
- **Coord3D_A16:** 3D coordinate, first component 16 bit.
- **Coord3D_B16:** 3D coordinate, second component 16 bit.
- **Coord3D_C16:** 3D coordinate, third component 16 bit.
- **Coord3D_ABC16:** 3D coordinates, 3 components 16 bit.
- **Coord3D_ABC16_Planar:** 3D coordinates, 3 components 16 bit planar.
- **Coord3D_A32f:** 3D coordinate, first component 32 bit float.

- **Coord3D_B32f**: 3D coordinate, second component 32 bit float.
- **Coord3D_C32f**: 3D coordinate, third component 32 bit float.
- **Coord3D_ABC32f**: 3D coordinates, 3 components 32 bit float.
- **Coord3D_ABC32f_Planar**: 3D coordinates, 3 components 32 bit float planar.
- **Confidence1**: Confidence data 1 bit.
- **Confidence1p**: Confidence data 1 bit packed.
- **Confidence8**: Confidence data 8 bit.
- **Confidence16**: Confidence data 16 bit.
- **Confidence32f**: Confidence data 32 bit float.
- **Raw8**: Raw 8 bit.
- **Raw16**: Raw 16 bit.
- **Mono12Packed**: Mono 12 bit packed (GigE Vision Specific).
- **BayerGR10Packed**: Bayer GR 10 bit packed (GigE Vision Specific).
- **BayerRG10Packed**: Bayer RG 10 bit packed (GigE Vision Specific).
- **BayerGB10Packed**: Bayer GB 10 bit packed (GigE Vision Specific).
- **BayerBG10Packed**: Bayer BG 10 bit packed (GigE Vision Specific).
- **BayerGR12Packed**: Bayer GR 12 bit packed (GigE Vision Specific).
- **BayerRG12Packed**: Bayer RG 12 bit packed (GigE Vision Specific).
- **BayerGB12Packed**: Bayer GB 12 bit packed (GigE Vision Specific).
- **BayerBG12Packed**: Bayer BG 12 bit packed (GigE Vision Specific).
- **RGB10V1Packed**: RGB 10 bit packed (GigE Vision Specific).
- **RGB12V1Packed**: RGB 12 bit packed (GigE Vision Specific).
- ...

Note that only a subset of the possible pixel formats is listed here.

See the **PixelFormat** feature for more details.

23.19 ChunkPixelDynamicRangeMin

Name	ChunkPixelDynamicRangeMin
Category	ChunkDataControl
Level	Recommended
Interface	IInteger

Access	Read
Unit	-
Visibility	Expert
Values	≥ 0

Returns the minimum value of dynamic range of the image included in the payload.

23.20 ChunkPixelDynamicRangeMax

Name	ChunkPixelDynamicRangeMax
Category	ChunkDataControl
Level	Recommended
Interface	IInteger
Access	Read
Unit	-
Visibility	Expert
Values	≥ 0

Returns the maximum value of dynamic range of the image included in the payload.

23.21 ChunkTimestamp

Name	ChunkTimestamp
Category	ChunkDataControl
Level	Recommended
Interface	IInteger
Access	Read
Unit	-
Visibility	Expert
Values	≥ 0

Returns the Timestamp of the image included in the payload at the time of the FrameStart internal event.

See Figure 5-3 for more details on FrameStart.

23.22 ChunkTimestampLatchValue

Name	ChunkTimestampLatchValue
Category	ChunkDataControl
Level	Recommended
Interface	IInteger
Access	Read
Unit	ns
Visibility	Expert
Values	≥ 0

Returns the last Timestamp latched with the TimestampLatch command.

23.23 ChunkLineStatusAll

Name	ChunkLineStatusAll
Category	ChunkDataControl
Level	Recommended
Interface	IInteger
Access	Read
Unit	-
Visibility	Expert
Values	≥ 0

Returns the status of all the I/O lines at the time of the FrameStart internal event.

23.24 ChunkCounterSelector

Name	ChunkCounterSelector
Category	ChunkDataControl
Level	Recommended
Interface	IEnumeration
Access	Read/Write
Unit	-
Visibility	Expert

Values	Counter0 (If 0 based), Counter1, Counter2,...
---------------	---

Selects which counter to retrieve data from.

Possible values are:

- **Counter0**: Selects the counter 0.
- **Counter1**: Selects the counter 1.
- **Counter2**: Selects the counter 2.
- ...

23.25 ChunkCounterValue

Name	ChunkCounterValue[ChunkCounterSelector]
Category	ChunkDataControl
Level	Recommended
Interface	IInteger
Access	Read
Unit	-
Visibility	Expert
Values	≥ 0

Returns the value of the selected Chunk counter at the time of the FrameStart event.

23.26 ChunkTimerSelector

Name	ChunkTimerSelector
Category	ChunkDataControl
Level	Recommended
Interface	IEnumeration
Access	Read/Write
Unit	-
Visibility	Expert
Values	Timer0 (If 0 based), Timer1, Timer2, ...

Selects which Timer to retrieve data from.

Possible values are:

- **Timer0:** Selects the first Timer.
- **Timer1:** Selects the first Timer.
- **Timer2:** Selects the second Timer.
- ...

23.27 ChunkTimerValue

Name	ChunkTimerValue[ChunkTimerSelector]
Category	ChunkDataControl
Level	Recommended
Interface	IFloat
Access	Read
Unit	us
Visibility	Expert
Values	>0

Returns the value of the selected Timer at the time of the FrameStart internal event.

23.28 ChunkScanLineSelector

Name	ChunkScanLineSelector
Category	ChunkDataControl
Level	Optional
Interface	IInteger
Access	Read/Write
Unit	-
Visibility	Expert
Values	-

Index for vector representation of one chunk value per line in an image.

23.29 ChunkEncoderSelector

Name	ChunkEncoderSelector
Category	ChunkDataControl
Level	Recommended
Interface	IEnumeration
Access	Read/Write
Unit	-
Visibility	Expert
Values	Encoder0 (If 0 based), Encoder1, Encoder2, ...

Selects which Encoder to retrieve data from.

Possible values are:

- **Encoder0:** Selects the first Encoder.
- **Encoder1:** Selects the first Encoder.
- **Encoder2:** Selects the second Encoder.
- ...

23.30 ChunkEncoderValue

Name	ChunkEncoderValue[ChunkEncoderSelector][ChunkScanLineSelector]
Category	ChunkDataControl
Level	Recommended
Interface	IInteger
Access	Read
Unit	-
Visibility	Expert
Values	-

Returns the counter's value of the selected Encoder at the time of the FrameStart in area scan mode or the counter's value at the time of the LineStart selected by ChunkScanLineSelector in Linescan mode.

23.31 ChunkEncoderStatus

Name	ChunkEncoderStatus[ChunkEncoderSelector][ChunkScanLineSelector]
Category	ChunkDataControl
Level	Optional
Interface	IEnumeration
Access	Read
Unit	-
Visibility	Expert
Values	EncoderUp EncoderDown EncoderIdle EncoderStatic

Returns the motion status of the selected encoder.

Possible values are:

- **EncoderUp:** The encoder counter last incremented.
- **EncoderDown:** The encoder counter last decremented.
- **EncoderIdle:** The encoder is not active.
- **EncoderStatic:** No motion within the EncoderTimeout time.

23.32 ChunkExposureTimeSelector

Name	ChunkExposureTimeSelector
Category	ChunkDataControl
Level	Optional
Interface	IEnumeration
Access	Read/Write
Unit	-
Visibility	Expert
Values	Common Red Green Blue Cyan

	Magenta Yellow Infrared Ultraviolet Stage1 Stage2 ...
--	---

Selects which exposure time is read by the **ChunkExposureTime** feature.

The possible values for **ChunkExposureTimeSelector** are:

- **Common:** Selects the common ExposureTime.
- **Red:** Selects the red common ExposureTime.
- **Green:** Selects the green ExposureTime.
- **Blue:** Selects the blue ExposureTime.
- **Cyan:** Selects the cyan common ExposureTime..
- **Magenta:** Selects the magenta ExposureTime..
- **Yellow:** Selects the yellow ExposureTime..
- **Infrared:** Selects the infrared ExposureTime.
- **Ultraviolet:** Selects the ultraviolet ExposureTime.
- **Stage1:** Selects the first stage ExposureTime.
- **Stage2:** Selects the second stage ExposureTime.
- ...

23.33 ChunkExposureTime

Name	ChunkExposureTime[ChunkExposureTimeSelector]
Category	ChunkDataControl
Level	Recommended
Interface	IFloat
Access	Read
Unit	us
Visibility	Expert
Values	≥0

Returns the exposure time used to capture the image.

23.34 ChunkGainSelector

Name	ChunkGainSelector
Category	ChunkDataControl
Level	Recommended
Interface	IEnumeration
Access	Read/Write
Unit	-
Visibility	Expert
Values	All Red Green Blue Y U V Tap1, Tap2, ... AnalogAll AnalogRed AnalogGreen AnalogBlue AnalogY AnalogU AnalogV AnalogTap1, AnalogTap2, ... DigitalAll DigitalRed DigitalGreen DigitalBlue DigitalY DigitalU DigitalV DigitalTap1, DigitalTap2, ...

Selects which Gain to return.

Possible values are:

- **All:** Gain will be applied to all channels or taps.
- **Red:** Gain will be applied to the red channel.
- **Green:** Gain will be applied to the green channel.

- **Blue:** Gain will be applied to the blue channel.
- **Y:** Gain will be applied to Y channel.
- **U:** Gain will be applied to U channel.
- **V:** Gain will be applied to V channel.
- **Tap1:** Gain will be applied to Tap 1.
- **Tap2:** Gain will be applied to Tap 2.
- ...
- **AnalogAll:** Gain will be applied to all analog channels or taps.
- **AnalogRed:** Gain will be applied to the red analog channel.
- **AnalogGreen:** Gain will be applied to the green analog channel.
- **AnalogBlue:** Gain will be applied to the blue analog channel.
- **AnalogY:** Gain will be applied to Y analog channel.
- **AnalogU:** Gain will be applied to U analog channel.
- **AnalogV:** Gain will be applied to V analog channel.
- **AnalogTap1:** Analog gain will be applied to Tap 1.
- **AnalogTap2:** Analog gain will be applied to Tap 2.
- ...
- **DigitalAll:** Gain will be applied to all digital channels or taps.
- **DigitalRed:** Gain will be applied to the red digital channel.
- **DigitalGreen:** Gain will be applied to the green digital channel.
- **DigitalBlue:** Gain will be applied to the blue digital channel.
- **DigitalY:** Gain will be applied to Y digital channel.
- **DigitalU:** Gain will be applied to U digital channel.
- **DigitalV:** Gain will be applied to V digital channel.
- **DigitalTap1:** Digital gain will be applied to Tap 1.
- **DigitalTap2:** Digital gain will be applied to Tap 2.
- ...

23.35 ChunkGain

Name	ChunkGain[ChunkGainSelector]
-------------	------------------------------

Category	ChunkDataControl
Level	Recommended
Interface	IFloat
Access	Read
Unit	-
Visibility	Expert
Values	Device-specific

Returns the gain used to capture the image.

23.36 ChunkBlackLevelSelector

Name	ChunkBlackLevelSelector
Category	ChunkDataControl
Level	Recommended
Interface	IEnumeration
Access	Read/Write
Unit	-
Visibility	Expert
Values	All Red Green Blue Y U V Tap1, Tap2, ...

Selects which Black Level to return. Possible values are:

- **All:** Black Level will be applied to all channels or taps.
- **Red:** Black Level will be applied to the red channel.
- **Green:** Black Level will be applied to the green channel.
- **Blue:** Black Level will be applied to the blue channel.
- **Y:** Black Level will be applied to Y channel.
- **U:** Black Level will be applied to U channel.

- **V**: Black Level will be applied to V channel.
- **Tap1**: Black Level will be applied to Tap 1.
- **Tap2**: Black Level will be applied to Tap 2.
- ...

23.37 ChunkBlackLevel

Name	ChunkBlackLevel[ChunkBlackLevelSelector]
Category	ChunkDataControl
Level	Recommended
Interface	IFloat
Access	Read
Unit	-
Visibility	Expert
Values	Device-specific

Returns the black level used to capture the image included in the payload.

23.38 ChunkLinePitch

Name	ChunkLinePitch
Category	ChunkDataControl
Level	Recommended
Interface	IInteger
Access	Read
Unit	B
Visibility	Expert
Values	>0

Returns the **LinePitch** of the image included in the payload.

23.39 ChunkFrameID

Name	ChunkFrameID
Category	ChunkDataControl
Level	Recommended

Interface	IInteger
Access	Read
Unit	-
Visibility	Expert
Values	≥ 0

Returns the unique Identifier of the frame (or image) included in the payload.

Recommended behavior of the identifier: It should start at a certain minimum value and keep incrementing by one for each frame up to a maximum, then it wraps to the minimum again. Each streaming channel should maintain the Frame ID separately.

Note: For GigE Vision, this chunk is not necessarily the block_id field included in the GVSP headers but can be equal to it.

23.40 ChunkSourceSelector

Name	ChunkSourceSelector
Category	ChunkDataControl
Level	Optional
Interface	IEnumeration
Access	Read/Write
Unit	-
Visibility	Expert
Values	Source0 (if 0 based) Source1 Source2 ...

Selects which Source to retrieve data from.

This generally maps to the corresponding SourceSelector feature.

Possible values are:

- **Source0**: Image comes from the Source 0.
- **Source1**: Image comes from the Source 1.
- **Source2**: Image comes from the Source 2.
- ...

23.41 ChunkSourceID

Name	ChunkSourceID
Category	ChunkDataControl
Level	Optional
Interface	IEnumeration
Access	Read
Unit	-
Visibility	Expert
Values	Source0 (if 0 based) Source1 Source2 ...

Returns the Identifier of Source that the image comes from.

This generally maps to the corresponding SourceSelector feature.

Possible values are:

- **Source0**: Image comes from the Source 0.
- **Source1**: Image comes from the Source 1.
- **Source2**: Image comes from the Source 2.
- ...

23.42 ChunkSourceIDValue

Name	ChunkSourceIDValue[ChunkSourceSelector]
Category	ChunkDataControl
Level	Recommended
Interface	IInteger
Access	Read
Unit	-
Visibility	Expert
Values	≥ 0

Returns the unique integer Identifier value of the Source that the image comes from.

This generally maps to the corresponding SourceIDValue feature.

23.43 ChunkTransferBlockID

Name	ChunkTransferBlockID
Category	ChunkDataControl
Level	Recommended
Interface	IInteger
Access	Read
Unit	-
Visibility	Expert
Values	≥ 0

Returns the unique identifier of the transfer block used to transport the payload.

The block ID is usually defined by the transport layer and repeated in the chunk for convenience.

23.44 ChunkTransferStreamID

Name	ChunkTransferStreamID
Category	ChunkDataControl
Level	Recommended
Interface	IEnumeration
Access	Read
Unit	-
Visibility	Expert
Values	Stream0 (if 0 based) Stream1 Stream2 Stream3 ...

Returns identifier of the stream that generated this block.

Possible values are:

- **Stream0**: Data comes from Stream0.
- **Stream1**: Data comes from Stream1.

- **Stream2:** Data comes from Stream2.
- **Stream3:** Data comes from Stream3.

Note that the Stream used can be changed using the RegionDestination feature.

23.45 ChunkTransferQueueCurrentBlockCount

Name	ChunkTransferQueueCurrentBlockCount
Category	ChunkDataControl
Level	Optional
Interface	IInteger
Access	Read
Unit	-
Visibility	Expert
Values	≥ 0

Returns the current number of blocks in the transfer queue.

23.46 ChunkStreamChannelID

Name	ChunkStreamChannelID
Category	ChunkDataControl
Level	Recommended
Interface	IInteger
Access	Read
Unit	-
Visibility	Expert
Values	> 0

Returns identifier of the stream channel used to carry the block.

Note that the Stream Channel used can be changed using the TransferStreamChannel feature.

23.47 ChunkSequencerSetActive

Name	ChunkSequencerSetActive
Category	ChunkDataControl

Level	Recommended
Interface	IInteger
Access	Read
Unit	-
Visibility	Expert
Values	≥ 0

Return the index of the active set of the running sequencer included in the payload.

23.48 ChunkScan3dDistanceUnit

Name	ChunkScan3dDistanceUnit
Category	ChunkDataControl
Level	Optional
Interface	IEnumeration
Access	Read
Unit	-
Visibility	Expert
Values	Millimeter Inch Device-specific

Returns the Distance Unit of the payload image.

Possible values are:

- **Millimeter**: Default value. Distance values are in millimeter units.
- **Inch**: Distance values are in inch units.

23.49 ChunkScan3dOutputMode

Name	ChunkScan3dOutputMode
Category	ChunkDataControl
Level	Optional
Interface	IEnumeration

Access	Read
Unit	-
Visibility	Expert
Values	UncalibratedC CalibratedABC_Grid CalibratedABC_PointCloud CalibratedAC CalibratedAC_Linescan CalibratedC CalibratedC_Linescan RectifiedC RectifiedC_Linescan DisparityC DisparityC_Linescan

Returns the Calibrated Mode of the payload image.

Possible values are:

- **UncalibratedC:** Uncalibrated 2.5D Depth map. The distance data does not represent a physical unit and may be non-linear. The data is a 2.5D range map only.
- **CalibratedABC_Grid:** 3 Coordinates in grid organization. The full 3 coordinate data with the grid array organization from the sensor kept.
- **CalibratedABC_PointCloud:** 3 Coordinates without organization. The full 3 coordinate data without any organization of data points. Typically only valid points transmitted giving varying image size.
- **CalibratedAC:** 2 Coordinates with fixed B sampling. The data is sent as a A and C coordinates (X,Z or Theta,Rho). The B (Y) axis uses the scale and offset parameters for the B axis.
- **CalibratedAC_Linescan:** 2 Coordinates with varying sampling. The data is sent as a A and C coordinates (X,Z or Theta,Rho). The B (Y) axis comes from the encoder chunk value.
- **CalibratedC:** Calibrated 2.5D Depth map. The distance data is expressed in the chosen distance unit. The data is a 2.5D range map. No information on X-Y axes available.
- **CalibratedC_Linescan:** Depth Map with varying B sampling. The distance data is expressed in the chosen distance unit. The data is a 2.5D range map. The B (Y) axis comes from the encoder chunk value.
- **RectifiedC:** Rectified 2.5D Depth map. The distance data has been rectified to a uniform sampling pattern in the X and Y direction. The data is a 2.5D range map only. If a complete 3D point cloud is rectified but transmitted as explicit coordinates it should be transmitted as one of the "CalibratedABC" formats.

- **RectifiedC_Linescan:** Rectified 2.5D Depth map with varying B sampling. The data is sent as rectified 1D profiles using Coord3D_C pixels. The B (Y) axis comes from the encoder chunk value.
- **DisparityC:** Disparity 2.5D Depth map. The distance is inversely proportional to the pixel (disparity) value.
- **DisparityC_Linescan:** Disparity 2.5D Depth map with varying B sampling. The distance is inversely proportional to the pixel (disparity) value. The B (Y) axis comes from the encoder chunk value.

23.50 ChunkScan3dCoordinateSystem

Name	ChunkScan3dCoordinateSystem
Category	ChunkDataControl
Level	Optional
Interface	IEnumeration
Access	Read
Unit	-
Visibility	Expert
Values	Cartesian Spherical Cylindrical Device-specific

Returns the Coordinate System of the image included in the payload.

Possible values are:

- **Cartesian:** Default value. 3-axis orthogonal, right-hand X-Y-Z.
- **Spherical:** A Theta-Phi-Rho coordinate system.
- **Cylindrical:** A Theta-Y-Rho coordinate system.

23.51 ChunkScan3dCoordinateSystemReference

Name	ChunkScan3dCoordinateSystemReference
Category	ChunkDataControl
Level	Optional
Interface	IEnumeration
Access	Read
Unit	-
Visibility	Expert

Values	Anchor Transformed
---------------	-----------------------

Returns the Coordinate System Position of the image included in the payload.

Possible values are:

- **Anchor:** Default value. Original fixed reference. The coordinate system fixed relative the camera reference point marker is used.
- **Transformed:** Transformed reference system. The transformed coordinate system is used according to the definition in the rotation and translation matrices.

23.52 ChunkScan3dCoordinateSelector

Name	ChunkScan3dCoordinateSelector
Category	ChunkDataControl
Level	Optional
Interface	IEnumeration
Access	Read/Write
Unit	-
Visibility	Expert
Values	CoordinateA CoordinateB CoordinateC

Selects which Coordinate to retrieve data from.

Possible values are:

- **CoordinateA:** The first (X or Theta) coordinate
- **CoordinateB:** The second (Y or Phi) coordinate
- **CoordinateC:** The third (Z or Rho) coordinate.

23.53 ChunkScan3dCoordinateScale

Name	ChunkScan3dCoordinateScale[ChunkScan3dCoordinateSelector]
Category	ChunkDataControl
Level	Optional
Interface	IFloat

Access	Read
Unit	-
Visibility	Expert
Values	-

Returns the Scale for the selected coordinate axis of the image included in the payload.

23.54 ChunkScan3dCoordinateOffset

Name	ChunkScan3dCoordinateOffset[ChunkScan3dCoordinateSelector]
Category	ChunkDataControl
Level	Optional
Interface	IFloat
Access	Read
Unit	-
Visibility	Expert
Values	-

Returns the Offset for the selected coordinate axis of the image included in the payload.

23.55 ChunkScan3dInvalidDataFlag

Name	ChunkScan3dInvalidDataFlag[ChunkScan3dCoordinateSelector]
Category	ChunkDataControl
Level	Optional
Interface	IBoolean
Access	Read
Unit	-
Visibility	Expert
Values	True False

Returns if a specific non-valid data flag is used in the data stream.

Possible values are:

- **False:** Default value. No specific value identifies missing or invalid points.
- **True:** The InvalidDataValue specifies a special non-valid value.

23.56 ChunkScan3dInvalidDataValue

Name	ChunkScan3dInvalidDataValue[ChunkScan3dCoordinateSelector]
Category	ChunkDataControl
Level	Optional
Interface	IFloat
Access	Read
Unit	-
Visibility	Expert
Values	-

Returns the Invalid Data Value used for the image included in the payload.

23.57 ChunkScan3dAxisMin

Name	ChunkScan3dAxisMin[ChunkScan3dCoordinateSelector]
Category	ChunkDataControl
Level	Optional
Interface	IFloat
Access	Read
Unit	-
Visibility	Expert
Values	-

Returns the Minimum Axis value for the selected coordinate axis of the image included in the payload.

23.58 ChunkScan3dAxisMax

Name	ChunkScan3dAxisMax[ChunkScan3dCoordinateSelector]
Category	ChunkDataControl
Level	Optional
Interface	IFloat

Access	Read
Unit	-
Visibility	Expert
Values	-

Returns the Maximum Axis value for the selected coordinate axis of the image included in the payload.

23.59 ChunkScan3dCoordinateTransformSelector

Name	ChunkScan3dCoordinateTransformSelector
Category	ChunkDataControl
Level	Optional
Interface	IEnumeration
Access	Read/Write
Unit	-
Visibility	Expert
Values	RotationX RotationY RotationZ TranslationX TranslationY TranslationZ

Selector for transform values.

Possible values are:

- **RotationX:** Rotation around X axis.
- **RotationY:** Rotation around Y axis.
- **RotationZ:** Rotation around Z axis.
- **TranslationX:** Translation along X axis.
- **TranslationY:** Translation along Y axis.
- **TranslationZ:** Translation along Z axis.

23.60 ChunkScan3dTransformValue

Name	ChunkScan3dTransformValue[ChunkScan3dCoordinateTransformSelector]
-------------	--

Category	ChunkDataControl
Level	Optional
Interface	IFloat
Access	Read
Unit	-
Visibility	Expert
Values	-

Returns the transform value.

23.61 ChunkScan3dCoordinateReferenceSelector

Name	ChunkScan3dCoordinateReferenceSelector
Category	ChunkDataControl
Level	Optional
Interface	IEnumeration
Access	Read/Write
Unit	-
Visibility	Expert
Values	RotationX RotationY RotationZ TranslationX TranslationY TranslationZ

Selector to read a coordinate system reference value defining the transform of a point from one system to the other.

The transformation from Anchor and Transformed to the Reference coordinate system should be implemented as described in section 21.2.2 (Coordinate system position and transformation). Here data describes the current transform, so no selection with Scan3dCoordinateSystemReference is needed.

Possible values are:

- **RotationX:** Rotation around X axis.
- **RotationY:** Rotation around Y axis.

- **RotationZ:** Rotation around Z axis.
- **TranslationX:** X axis translation.
- **TranslationY:** Y axis translation.
- **TranslationZ:** Z axis translation.

23.62 ChunkScan3dCoordinateReferenceValue

Name	ChunkScan3dCoordinateReferenceValue[ChunkScan3dCoordinateReferenceSelector]
Category	ChunkDataControl
Level	Optional
Interface	IFloat
Access	Read
Unit	-
Visibility	Expert
Values	-

Returns the value of a position or pose coordinate for the anchor or transformed coordinate systems relative to the reference point.

23.63 ChunkScan3dFocalLength

Name	ChunkScan3dFocalLength
Category	ChunkDataControl
Level	Optional
Interface	IFloat
Access	Read
Unit	Pixel
Visibility	Expert
Values	> 0

Returns the focal length of the camera in pixel. The focal length depends on the selected region. The value of this feature takes into account horizontal binning, decimation, or any other function changing the image resolution.

23.64 ChunkScan3dBaseline

Name	ChunkScan3dBaseline
Category	ChunkDataControl
Level	Optional
Interface	IFloat
Access	Read
Unit	m
Visibility	Expert
Values	> 0

Returns the baseline as the physical distance of two cameras in a stereo camera setup. The value of this feature can be used for 3D reconstruction from disparity images. In this case, the unit of the 3D coordinates corresponds to the unit of the baseline.

23.65 ChunkScan3dPrincipalPointU

Name	ChunkScan3dPrincipalPointU
Category	ChunkDataControl
Level	Optional
Interface	IFloat
Access	Read
Unit	Pixel
Visibility	Expert
Values	-

Returns the value of this feature gives the horizontal position of the principal point, relative to the region origin, i.e. OffsetX. The value of this feature takes into account horizontal binning, decimation, or any other function changing the image resolution.

23.66 ChunkScan3dPrincipalPointV

Name	ChunkScan3dPrincipalPointV
Category	ChunkDataControl
Level	Optional
Interface	IFloat
Access	Read
Unit	Pixel
Visibility	Expert
Values	-

Returns the value of this feature gives the vertical position of the principal point, relative to the region origin, i.e. OffsetY. The value of this feature takes into account vertical binning, decimation, or any other function changing the image resolution.

24 Test Control

Contains the features related to the control of the test features.

24.1 TestControl

Name	TestControl
Category	Root
Level	Recommended
Interface	ICategory
Access	Read
Unit	-
Visibility	Guru
Values	-

Category for Test Control features.

24.2 TestPendingAck

Name	TestPendingAck
Category	TestControl
Level	Optional
Interface	IInteger
Access	Read/Write
Unit	ms
Visibility	Guru
Values	≥ 0

Tests the device's pending acknowledge feature. When this feature is written, the device waits a time period corresponding to the value of **TestPendingAck** before acknowledging the write.

If this time period is longer than the maximum device response time specified by **DeviceLinkCommandTimeout**, the device must use a pending acknowledge during the completion of this request.

When read, the device returns the current feature value without additional wait time before the acknowledge.

24.3 TestEventGenerate

Name	TestEventGenerate
Category	TestControl
Level	Optional
Interface	ICommand
Access	(Read)/Write
Unit	-
Visibility	Guru
Values	≥ 0

Generates a Test Event.

If this feature is present, an **EventTestData** category containing the **EventTest** and **EventTestTimestamp** features must be implemented in the **EventControl** category.

Note: The Test event does not need to be included in EventSelector since the notification of this event is always enabled.

24.4 TestPayloadFormatMode

Name	TestPayloadFormatMode
Category	TestControl
Level	Recommended
Interface	IEnumeration
Access	Read/Write
Unit	-
Visibility	Guru
Values	Off (default) MultiPart

This feature allows setting a device in test mode and to output a specific payload format for validation of data streaming. This feature is intended solely for test purposes. The data can be real acquired data or any test pattern.

- **Off:** The test mode is disabled. This feature has no effect and the device is streaming data normally according to its configuration. This option has to be the default after each boot of the device.

- **MultiPart:** The device streams data using multi-part payload format with at least one part in each frame. This option must be present if and only if the device supports the multi-part payload format. If the underlying transport layer negotiation has failed to allow the device to enter multi-part mode, it must not be possible to enable this test mode.

25 GenICam Control

This chapter provides the necessary features to use the GenICam feature tree.

Note: In case of discrepancy between the features described in this chapter and the "GenICam Standard text" the SFNC document prevail.

25.1 GenICam feature tree access

The mandatory features below are necessary to access the GenICam features tree.

25.1.1 Root

Name	Root
Category	None
Level	Mandatory
Interface	ICategory
Access	Read
Unit	-
Mandatory Visibility	Beginner
Values	-

Provides the Root of the GenICam features tree.

25.1.2 Device

Name	Device
Category	None
Level	Mandatory
Interface	IPort
Access	Read/Write
Unit	-
Visibility	Invisible
Values	-

Provides the default GenICam port of the Device.

Note: **Device** is the name of the standard port that is used to connect the node map to the transport layer and access the control port of the device. **Device** is a port node (not a feature node) and is generally not accessed by the end user directly. **Device** must not be included in the root feature tree.

26 Transport Layer Control

This chapter provides the Transport Layer control features.

In general the generic features are directly under the TransportLayerControl category and the other Transport Layer specific features are under their respective sub category.

26.1 TLParamsLocked Usage

TLParamsLocked related features are used to lock the state of certain features during acquisition.

By default, **TLParamsLocked** should be zero or unlocked in order to allow full device configuration. When the transmitter is configured properly, the receiver sets the TLParamsLocked feature of the transmitter to one which locks its transport layer related features. This allows starting the acquisition. The TLParamsLocked feature must be kept locked as long as the acquisition and transfer are active.

There are different groups of features that can be locked. Those groups are selected using the **TLParamsLockedSelector**. A feature must follow the rules of the group in which it falls. Features that affect other features must follow the rules of the more restrictive group of feature it is affecting. For example binning features also affect image size features. When a feature does not affect any predefined group, the device is free to decide if the feature is locked by TLParamsLocked.

Streaming Channel Control

Features that are related to the configuration of the streaming channel must be locked by the TLParamsLocked feature. Streaming channel configuration features are used to change the streaming channel behavior, packet formatting or usage of the physical link.

Data Flow Control

When the transport layer features are unlocked, both the AcquisitionStart and TransferStart features should be locked to prevent a user from starting an acquisition in an invalid state.

Stream Content

Not all transmitters and receivers have the same capability when it comes to dynamic change in the stream content. By default, all features that can modify the image size or pixel format should be locked by the TLParamsLocked feature. A device can implement the **TLParamsLockedSelector** and **TLParamsLockedState** feature to change to allow more precise control on the features locking.

26.2 Transport Layer features

This section describes the general transport layer features.

26.2.1 TransportLayerControl

Name	TransportLayerControl
------	-----------------------

Category	Root
Level	Recommended
Interface	ICategory
Access	Read
Unit	-
Visibility	Beginner
Values	-

Category that contains the transport Layer control features.

26.2.2 TLParamsLocked

Name	TLParamsLocked
Category	TransportLayerControl
Level	Mandatory
Interface	IInteger
Access	Read/Write
Unit	-
Visibility	Invisible
Values	-

Used by the Transport Layer to prevent critical features from changing during acquisition.

Possible values are:

- 0 : No features are locked.
- 1 : Transport Layer and Device critical features are locked and cannot be changed.

26.2.3 TLParamsLockedSelector

Name	TLParamsLockedSelector
Category	TransportLayerControl
Level	Optional

Interface	IEnumeration
Access	Read/(Write)
Unit	-
Visibility	Guru
Values	ImageSize PixelFormat PixelSize ExtendedPayload Device-specific

Selects the type of feature for which the locking behavior will be configured.

TLParamsLockedSelector can take one of the following values:

- **ImageSize:** Controls if the images size is locked during the acquisition. ImageSize represents width and height for area-scan cameras; it only represents width for linescan cameras.
- **PixelFormat:** Controls if the pixel format (**PixelFormat**) is locked during an acquisition.
- **PixelSize:** Controls if the size of the pixel can change during an acquisition. When locked, the **PixelFormat** is allowed to change as long as **PixelSize** is not affected.
- **ExtendedPayload:** Controls if a device is allowed to switch between a payload and its extended version during an acquisition.

26.2.4 TLParamsLockedState

Name	TLParamsLockedState[TLParamsLockedSelector]
Category	TransportLayerControl
Level	Optional
Interface	IBoolean
Access	Read/(Write)
Unit	-
Visibility	Guru
Values	True False

Controls if the selected parameters are locked during acquisition.

Locking certain parameters during acquisition includes respecting **TLParamsLocked** as well as preventing internal changes from modules like sequencer or multiple regions.

26.2.5 PayloadSize

Name	PayloadSize
Category	TransportLayerControl
Level	Recommended
Interface	IInteger
Access	Read
Unit	B
Visibility	Expert
Values	≥ 0

Provides the number of bytes transferred for each image or chunk on the stream channel. This includes any end-of-line, end-of-frame statistics or other stamp data. This is the total size of data payload for a data block.

For the devices supporting multiple Stream Channels, the DeviceStreamChannelSelector feature should be used to select PayloadSize. This permits to inquire the payload size of each Stream channel individually.

This feature is mainly used by the application software to determine size of image buffers to allocate (largest buffer possible for current mode of operation).

For example, an image with no statistics or timestamp data has typically a **PayloadSize** equals to (width x height x pixel size) in bytes. But it is strongly recommended to retrieve **PayloadSize** from the camera instead of relying on the above formula.

This feature is generally mandatory for transmitters and transceivers of most Transport Layers.

26.2.6 DeviceTapGeometry

Name	DeviceTapGeometry
Category	TransportLayerControl
Level	Recommended
Interface	IEnumeration
Access	Read/(Write)
Unit	-
Visibility	Expert

Values

Geometry_1X_1Y
 Geometry_1X2_1Y
 Geometry_1X2_1Y2
 Geometry_2X_1Y
 Geometry_2X_1Y2
 Geometry_2XE_1Y
 Geometry_2XE_1Y2
 Geometry_2XM_1Y
 Geometry_2XM_1Y2
 Geometry_1X_1Y2
 Geometry_1X_2YE
 Geometry_1X3_1Y
 Geometry_3X_1Y
 Geometry_1X
 Geometry_1X2
 Geometry_2X
 Geometry_2XE
 Geometry_2XM
 Geometry_1X3
 Geometry_3X
 Geometry_1X4_1Y
 Geometry_4X_1Y
 Geometry_2X2_1Y
 Geometry_2X2E_1Y
 Geometry_2X2M_1Y
 Geometry_1X2_2YE
 Geometry_2X_2YE
 Geometry_2XE_2YE
 Geometry_2XM_2YE
 Geometry_1X4
 Geometry_4X
 Geometry_2X2
 Geometry_2X2E
 Geometry_2X2M
 Geometry_1X8_1Y
 Geometry_8X_1Y
 Geometry_4X2_1Y
 Geometry_2X2E_2YE
 Geometry_1X8
 Geometry_8X
 Geometry_4X2
 Geometry_4X2E
 Geometry_4X2E_1Y
 Geometry_1X10_1Y
 Geometry_10X_1Y

	Geometry_1X10 Geometry_10X ...
--	--------------------------------------

This device tap geometry feature describes the geometrical properties characterizing the taps of a camera as presented at the output of the device.

Possibles values are:

Geometry_1X_1Y: 1 X 1Y tap geometry.

Geometry_1X2_1Y: 1 X2 1Y tap geometry.

Geometry_1X2_1Y2: 1 X2 1Y2 tap geometry.

Geometry_2X_1Y: 2 X 1Y tap geometry.

Geometry_2X_1Y2: 2 X 1Y2 tap geometry.

Geometry_2XE_1Y: 2 XE 1Y tap geometry.

Geometry_2XE_1Y2: 2 XE 1Y2 tap geometry.

Geometry_2XM_1Y: 2 XM 1Y tap geometry.

Geometry_2XM_1Y2: 2 XM 1Y2 tap geometry.

Geometry_1X_1Y2: 1 X 1Y2 tap geometry.

Geometry_1X_2YE: 1 X 2YE tap geometry.

Geometry_1X3_1Y: 1 X3 1Y tap geometry.

Geometry_3X_1Y: 3 X 1Y tap geometry.

Geometry_1X: 1 X tap geometry.

Geometry_1X2: 1 X2 tap geometry.

Geometry_2X: 2 X tap geometry.

Geometry_2XE: 2 XE tap geometry.

Geometry_2XM: 2 XM tap geometry.

Geometry_1X3: 1 X3 tap geometry.

Geometry_3X: 3 X tap geometry.

Geometry_1X4_1Y: 1 X4 1Y tap geometry.

Geometry_4X_1Y: 4 X 1Y tap geometry.

Geometry_2X2_1Y: 2 X2 1Y tap geometry.

Geometry_2X2E_1Y: 2 X2E 1Y tap geometry.

Geometry_2X2M_1Y: 2 X2M 1Y tap geometry.

Geometry_1X2_2YE: 1 X2 2YE tap geometry.
Geometry_2X_2YE: 2 X 2YE tap geometry.
Geometry_2XE_2YE: 2 XE 2YE tap geometry.
Geometry_2XM_2YE: 2 XM 2YE tap geometry.
Geometry_1X4: 1 X4 tap geometry.
Geometry_4X: 4X tap geometry.
Geometry_2X2: 2 X2 tap geometry.
Geometry_2X2E: 2 X2E tap geometry.
Geometry_2X2M: 2 X2M tap geometry.
Geometry_1X8_1Y: 1 X8 1Y tap geometry.
Geometry_8X_1Y: 8X 1Y tap geometry.
Geometry_4X2_1Y: 4 X2 1Y tap geometry.
Geometry_2X2E_2YE: 2 X2E 2YE tap geometry.
Geometry_1X8: 1 X8 tap geometry.
Geometry_8X: 8X tap geometry.
Geometry_4X2: 4 X2 tap geometry.
Geometry_4X2E: 4 X2E tap geometry.
Geometry_4X2E_1Y: 4 X2E 1Y tap geometry.
Geometry_1X10_1Y: 1 X10 1Y tap geometry.
Geometry_10X_1Y: 10X 1Y tap geometry.
Geometry_1X10: 1 X10 tap geometry.
Geometry_10X: X10 1Y tap geometry.

More detailed explanation, including graphical representation for every single Tap configuration is provided in the Tap Geometry Appendix of this document.

26.3 PTP Control

This section describes the Precision Time Protocol (PTP) control features.

26.3.1 PtpControl

Name	PtpControl
Category	TransportLayerControl
Level	Optional
Interface	ICategory
Access	Read
Unit	-
Visibility	Expert
Values	-

Category that contains the features related to the Precision Time Protocol (PTP) of the device.

26.3.2 PtpEnable

Name	PtpEnable
Category	PtpControl
Level	Optional
Interface	IBoolean
Access	Read/Write
Unit	-
Visibility	Expert
Values	True False

Enables the Precision Time Protocol (PTP).

26.3.3 PtpClockAccuracy

Name	PtpClockAccuracy
Category	PtpControl
Level	Optional
Interface	IEnumeration
Access	Read
Unit	-
Visibility	Expert
Values	Within25ns Within100ns Within250ns Within1us Within2p5u Within10us Within25us Within100us Within250us Within1ms Within2p5ms Within10ms Within25ms Within100ms Within250ms Within1s Within10s GreaterThan10s AlternatePTPProfile Unknown Reserved

Indicates the expected accuracy of the device PTP clock when it is the grandmaster, or in the event it becomes the grandmaster.

26.3.4 PtpDataSetLatch

Name	PtpDataSetLatch
Category	PtpControl
Level	Optional
Interface	ICommand
Access	Write
Unit	-
Visibility	Expert
Values	-

Latches the current values from the device’s PTP clock data set.

26.3.5 PtpStatus

Name	PtpStatus
Category	PtpControl
Level	Optional
Interface	IEnumeration
Access	Read
Unit	-
Visibility	Expert
Values	Initializing Faulty Disabled Listening PreMaster Master Passive Uncalibrated Slave

Returns the latched state of the PTP clock.

The state is indicated by values 1 to 9, corresponding to the states INITIALIZING, FAULTY, DISABLED, LISTENING, PRE_MASTER, MASTER, PASSIVE, UNCALIBRATED, and SLAVE. Refer to the IEEE 1588-2008 specification for additional information.

26.3.6 PtpServoStatus

Name	PtpServoStatus
Category	PtpControl
Level	Optional
Interface	IEnumeration
Access	Read
Unit	-
Visibility	Expert
Values	Unknown Locked Device-Specific

Returns the latched state of the clock servo. When the servo is in a locked state, the value returned is

‘Locked’. When the servo is in a non-locked state, a device-specific value can be returned to give specific information. If no device-specific value is available to describe the current state of the clock servo, the value should be ‘Unknown’.

26.3.7 PtpOffsetFromMaster

Name	PtpOffsetFromMaster
Category	PtpControl
Level	Optional
Interface	IInteger
Access	Read
Unit	ns
Visibility	Expert
Values	

Returns the latched offset from the PTP master clock in nanoseconds.

26.3.8 PtpClockID

Name	PtpClockId
Category	PtpControl
Level	Optional
Interface	IInteger
Access	Read
Unit	-
Visibility	Expert
Values	-

Returns the latched clock ID of the PTP device. PTP Parent Clock ID.

Note: Byte 0 of the IEEE ClockIdentity field is mapped to the MSB.

26.3.9 PtpParentClockID

Name	PtpParentClockId
Category	PtpControl
Level	Optional
Interface	IInteger
Access	Read
Unit	-
Visibility	Expert
Values	-

Returns the latched parent clock ID of the PTP device. The parent clock ID is the clock ID of the current master clock.

Note: Byte 0 of the IEEE ClockIdentity field is mapped to the MSB.

26.3.10 PtpGrandmasterClockID

Name	PtpGrandmasterClockID
Category	PtpControl
Level	Optional
Interface	Integer
Access	Read
Unit	-
Visibility	Expert
Values	-

Returns the latched grandmaster clock ID of the PTP device. The grandmaster clock ID is the clock ID of the current grandmaster clock.

Note: Byte 0 of the IEEE ClockIdentity field is mapped to the MSB.

26.4 GigE Vision features

This section describes the GigE Vision specific transport layer features.

26.4.1 GigE Vision

Name	GigE Vision
Category	TransportLayerControl
Level	Optional
Interface	ICategory
Access	Read
Unit	-
Visibility	Beginner
Values	-

Category that contains the features pertaining to the GigE Vision transport layer of the device.

26.4.2 GevVersionMajor (Deprecated)

Name	GevVersionMajor
Category	GigE Vision
Level	Recommended
Interface	Integer
Access	Read
Unit	-
Visibility	Invisible
Values	>0

This feature is deprecated (See DeviceTLVersionMajor). It was representing the major version of the specification.

For instance, GigE Vision version 1.0 would have the major version set to 1.

26.4.3 GevVersionMinor (Deprecated)

Name	GevVersionMinor
Category	GigE Vision
Level	Recommended

Interface	IInteger
Access	Read
Unit	-
Visibility	Invisible
Values	≥ 0

This feature is deprecated (See DeviceTLVersionMinor). It was representing the minor version of the specification.

For instance, GigE Vision version 1.0 would have the minor version set to 0.

26.4.4 GevDeviceModelsBigEndian (Deprecated)

Name	GevDeviceModelsBigEndian
Category	GigEVision
Level	Optional
Interface	IBoolean
Access	Read
Unit	-
Visibility	Invisible
Values	True False

This feature is deprecated (See DeviceRegistersEndianness). It was representing the Endianness of the device registers.

26.4.5 GevDeviceClass (Deprecated)

Name	GevDeviceClass
Category	GigEVision
Level	Optional
Interface	IEnumeration
Access	Read
Unit	-
Visibility	Invisible
Values	Transmitter

	Receiver Transceiver Peripheral
--	---------------------------------------

This feature is deprecated (See DeviceType). It was representing the class of the device.

Note: The **GevDeviceClass** feature returns **Transmitter** for cameras.

26.4.6 GevDeviceModeCharacterSet (Deprecated)

Name	GevDeviceModeCharacterSet
Category	GigEVision
Level	Optional
Interface	IEnumeration
Access	Read
Unit	-
Visibility	Invisible
Values	UTF8

This feature is deprecated (See DeviceCharacterSet). It was representing the character set used by all the strings of the bootstrap registers.

26.4.7 GevPhysicalLinkConfiguration

Name	GevPhysicalLinkConfiguration
Category	GigEVision
Level	Optional
Interface	IEnumeration
Access	Read/Write
Unit	-
Visibility	Expert
Values	SingleLink MultiLink StaticLAG DynamicLAG

Controls the principal physical link configuration to use on next restart/power-up of the device.

26.4.8 GevCurrentPhysicalLinkConfiguration

Name	GevCurrentPhysicalLinkConfiguration
Category	GigEVision
Level	Optional
Interface	IEnumeration
Access	Read
Unit	-
Visibility	Expert
Values	SingleLink MultiLink StaticLAG DynamicLAG

Indicates the current physical link configuration of the device.

Note: When Multi-Link and LAG configurations are used concurrently, the device shall report the LAG configuration.

26.4.9 GevActiveLinkCount (Deprecated)

Name	GevActiveLinkCount
Category	GigEVision
Level	Optional
Interface	IInteger
Access	Read
Unit	-
Visibility	Invisible
Values	> 0

Indicates the current number of active logical links.

26.4.10 GevSupportedOptionSelector

Name	GevSupportedOptionSelector
Category	GigEVision
Level	Optional

Interface	IEnumeration
Access	Read/Write
Unit	-
Visibility	Expert
Values	<ul style="list-style-type: none"> SingleLink MultiLink StaticLAG DynamicLAG PAUSEFrameReception PAUSEFrameGeneration IPConfigurationLLA IPConfigurationDHCP IPConfigurationPersistentIP StreamChannelSourceSocket StandardIDMode MessageChannelSourceSocket CommandsConcatenation WriteMem PacketResend Event EventData PendingAck IEEE1588 (deprecated) Ptp Action UnconditionalAction ScheduledAction PrimaryApplicationSwitchover ExtendedStatusCodes ExtendedStatusCodesVersion2_0 DiscoveryAckDelay DiscoveryAckDelayWritable TestData ManifestTable CCPApplicationSocket LinkSpeed HeartbeatDisable SerialNumber UserDefinedName StreamChannel0BigAndLittleEndian StreamChannel0IPReassembly StreamChannel0MultiZone StreamChannel0PacketResendDestination

	StreamChannel0AllInTransmission StreamChannel0UnconditionalStreaming StreamChannel0ExtendedChunkData StreamChannel1BigAndLittleEndian StreamChannel1IPReassembly StreamChannel1MultiZone StreamChannel1PacketResendDestination StreamChannel1AllInTransmission StreamChannel1UnconditionalStreaming StreamChannel1ExtendedChunkData StreamChannel2BigAndLittleEndian StreamChannel2IPReassembly StreamChannel2MultiZone StreamChannel2PacketResendDestination StreamChannel2AllInTransmission StreamChannel2UnconditionalStreaming StreamChannel2ExtendedChunkData ...
--	---

Selects the GEV option to interrogate for existing support.

Note: The IP reassembly options (**StreamChannel0IPReassembly**, **StreamChannel1IPReassembly**, ...) are only applicable to GVSP receiver stream channels.

26.4.11 **GevSupportedOption**

Name	GevSupportedOption[GevSupportedOptionSelector]
Category	GigEVision
Level	Optional
Interface	IBoolean
Access	Read
Unit	-
Visibility	Expert
Values	True False

Returns if the selected GEV option is supported.

26.4.12 **GevInterfaceSelector**

Name	GevInterfaceSelector
Category	GigE Vision
Level	Optional
Interface	IInteger
Access	Read/Write
Unit	-
Visibility	Beginner
Values	≥ 0

Selects which logical link to control.

Note: The number of physical network interfaces may be greater than the value reported by **GevInterfaceSelector**. This is generally the case when link aggregation is activated.

26.4.13 **GevLinkSpeed (Deprecated)**

Name	GevLinkSpeed[GevInterfaceSelector]
Category	GigE Vision
Level	Optional
Interface	IInteger
Access	Read
Unit	Mbs
Visibility	Invisible
Values	> 0

This feature is deprecated (See DeviceLinkSpeed). It was representing the speed of transmission negotiated by the given logical link.

26.4.14 **GevMACAddress**

Name	GevMACAddress[GevInterfaceSelector]
Category	GigE Vision
Level	Optional
Interface	IInteger

Access	Read
Unit	-
Visibility	Beginner
Values	≥ 0

MAC address of the logical link.

This feature must return a 64-bit value representing the full MAC address of the device (i.e. the high and low parts).

26.4.15 **GevPAUSEFrameReception**

Name	GevPAUSEFrameReception[GevInterfaceSelector]
Category	GigEVision
Level	Optional
Interface	IBoolean
Access	Read/(Write)
Unit	-
Visibility	Expert
Values	True False

Controls whether incoming PAUSE Frames are handled on the given logical link.

26.4.16 **GevPAUSEFrameTransmission**

Name	GevPAUSEFrameTransmission[GevInterfaceSelector]
Category	GigEVision
Level	Optional
Interface	IBoolean
Access	Read/(Write)
Unit	-
Visibility	Expert
Values	True False

Controls whether PAUSE Frames can be generated on the given logical link.

26.4.17 **GevCurrentIPConfigurationLLA**

Name	GevCurrentIPConfigurationLLA[GevInterfaceSelector]
Category	GigEVision
Level	Optional
Interface	IBoolean
Access	Read/Write
Unit	-
Visibility	Beginner
Values	True

Controls whether the Link Local Address IP configuration scheme is activated on the given logical link.

Note: Currently as per the GigE Vision specification, LLA cannot be disabled.

26.4.18 **GevCurrentIPConfigurationDHCP**

Name	GevCurrentIPConfigurationDHCP[GevInterfaceSelector]
Category	GigEVision
Level	Optional
Interface	IBoolean
Access	Read/Write
Unit	-
Visibility	Beginner
Values	True False

Controls whether the DHCP IP configuration scheme is activated on the given logical link.

26.4.19 **GevCurrentIPConfigurationPersistentIP**

Name	GevCurrentIPConfigurationPersistentIP[GevInterfaceSelector]
Category	GigEVision
Level	Optional
Interface	IBoolean

Access	Read/Write
Unit	-
Visibility	Beginner
Values	True False

Controls whether the PersistentIP configuration scheme is activated on the given logical link.

26.4.20 **GevCurrentIPAddress**

Name	GevCurrentIPAddress[GevInterfaceSelector]
Category	GigEVision
Level	Optional
Interface	IInteger
Access	Read
Unit	-
Visibility	Beginner
Values	≥ 0

Reports the IP address for the given logical link.

26.4.21 **GevCurrentSubnetMask**

Name	GevCurrentSubnetMask[GevInterfaceSelector]
Category	GigEVision
Level	Optional
Interface	IInteger
Access	Read
Unit	-
Visibility	Beginner
Values	≥ 0

Reports the subnet mask of the given logical link.

26.4.22 **GevCurrentDefaultGateway**

Name	GevCurrentDefaultGateway[GevInterfaceSelector]
Category	GigE Vision
Level	Optional
Interface	IInteger
Access	Read
Unit	-
Visibility	Beginner
Values	≥0

Reports the default gateway IP address of the given logical link.

26.4.23 **GevIPConfigurationStatus**

Name	GevIPConfigurationStatus[GevInterfaceSelector]
Category	GigE Vision
Level	Optional
Interface	IEnumeration
Access	Read
Unit	-
Visibility	Beginner
Values	None PersistentIP DHCP LLA ForceIP

Reports the current IP configuration status.

26.4.24 **GevFirstURL (Deprecated)**

Name	GevFirstURL
Category	GigE Vision
Level	Optional
Interface	IString

Access	Read
Unit	-
Visibility	Invisible
Values	-

Indicates the first URL to the GenICam XML device description file. The First URL is used as the first choice by the application to retrieve the GenICam XML device description file.

26.4.25 **GevSecondURL(Deprecated)**

Name	GevSecondURL
Category	GigEVision
Level	Optional
sequInterface	IString
Access	Read
Unit	-
Visibility	Invisible
Values	-

Indicates the second URL to the GenICam XML device description file. This URL is an alternative if the application was unsuccessful to retrieve the device description file using the first URL.

26.4.26 **GevNumberOfInterfaces (Deprecated)**

Name	GevNumberOfInterfaces
Category	GigEVision
Level	Optional
Interface	IInteger
Access	Read
Unit	-
Visibility	Invisible
Values	>0

This feature is deprecated (See DeviceLinkSelector). It was representing the number of logical links supported by this device.

26.4.27 **GevPersistentIPAddress**

Name	GevPersistentIPAddress[GevInterfaceSelector]
Category	GigEVision
Level	Optional
Interface	IInteger
Access	Read/Write
Unit	-
Visibility	Beginner
Values	≥ 0

Controls the Persistent IP address for this logical link. It is only used when the device boots with the Persistent IP configuration scheme.

26.4.28 **GevPersistentSubnetMask**

Name	GevPersistentSubnetMask[GevInterfaceSelector]
Category	GigEVision
Level	Optional
Interface	IInteger
Access	Read/Write
Unit	-
Visibility	Beginner
Values	≥ 0

Controls the Persistent subnet mask associated with the Persistent IP address on this logical link. It is only used when the device boots with the Persistent IP configuration scheme.

26.4.29 **GevPersistentDefaultGateway**

Name	GevPersistentDefaultGateway[GevInterfaceSelector]
Category	GigEVision
Level	Optional
Interface	IInteger
Access	Read/Write

Unit	-
Visibility	Beginner
Values	≥ 0

Controls the persistent default gateway for this logical link. It is only used when the device boots with the Persistent IP configuration scheme.

26.4.30 GevMessageChannelCount (Deprecated)

Name	GevMessageChannelCount
Category	GigEVision
Level	Optional
Interface	IInteger
Access	Read
Unit	-
Visibility	Invisible
Values	0 or 1

This feature is deprecated (See DeviceEventChannelCount). It was representing the number of message channels supported by this device.

26.4.31 GevStreamChannelCount (Deprecated)

Name	GevStreamChannelCount
Category	GigEVision
Level	Optional
Interface	IInteger
Access	Read
Unit	-
Visibility	Invisible
Values	0 to 512

This feature is deprecated (See DeviceStreamChannelCount). It was representing the number of stream channels supported by this device.

26.4.32 GevHeartbeatTimeout (Deprecated)

Name	GevHeartbeatTimeout
Category	GigEVision
Level	Optional
Interface	IInteger
Access	Read/Write
Unit	ms
Visibility	Guru
Values	>0

This feature is deprecated (See DeviceLinkHeartbeatTimeout). It was controlling the current heartbeat timeout in milliseconds.

26.4.33 GevTimestampTickFrequency (Deprecated)

Name	GevTimestampTickFrequency
Category	GigEVision
Level	Optional
Interface	IInteger
Access	Read
Unit	Hz
Visibility	Invisible
Values	≥0

This feature is deprecated (See the increment of the TimestampLatchValue feature). It was used to indicate the number of timestamp ticks in 1 second (frequency in Hz). If PTP is used, this feature must return 1,000,000,000 (1 GHz).

This is a 64 bits number.

26.4.34 GevTimestampControlLatch (Deprecated)

Name	GevTimestampControlLatch
Category	GigEVision
Level	Optional
Interface	ICommand

Access	Write
Unit	-
Visibility	Invisible
Values	-

This feature is deprecated (See TimestampLatch). It was used to latch the current timestamp counter into `GevTimestampValue`.

26.4.35 **GevTimestampControlReset (Deprecated)**

Name	<code>GevTimestampControlReset</code>
Category	GigEVision
Level	Optional
Interface	<code>ICommand</code>
Access	Write
Unit	-
Visibility	Invisible
Values	-

This feature is deprecated (See TimestampReset). It was used to reset the timestamp counter to 0. This feature is not available or as no effect when PTP is used.

26.4.36 **GevTimestampValue (Deprecated)**

Name	<code>GevTimestampValue</code>
Category	GigEVision
Level	Optional
Interface	<code>IInteger</code>
Access	Read
Unit	
Visibility	Invisible
Values	≥ 0

This feature is deprecated (See TimestampLatchValue). It was used to return the latched 64-bit value of the timestamp counter.

It is necessary to latch the 64-bit timestamp value to guaranty its integrity when performing the two 32-bit read accesses to retrieve the higher and lower 32-bit portions.

26.4.37 *GevDiscoveryAckDelay*

Name	GevDiscoveryAckDelay
Category	GigEVision
Level	Optional
Interface	IInteger
Access	Read/(Write)
Unit	ms
Visibility	Expert
Values	≥0 and < 1000

Indicates the maximum randomized delay the device will wait to acknowledge a discovery command.

26.4.38 *GevIEEE1588 (Deprecated)*

Name	GevIEEE1588
Category	GigEVision
Level	Optional
Interface	IBoolean
Access	Read/Write
Unit	-
Visibility	Invisible
Values	True False

This feature is deprecated (See PtpEnable). It was used to enable the IEEE 1588 Precision Time Protocol to control the timestamp register.

26.4.39 *GevIEEE1588ClockAccuracy (Deprecated)*

Name	GevIEEE1588ClockAccuracy
Category	GigEVision
Level	Optional

Interface	IEnumeration
Access	Read/(Write)
Unit	-
Visibility	Invisible
Values	Within25ns Within100ns Within250ns Within1us Within2p5u Within10us Within25us Within100us Within250us Within1ms Within2p5ms Within10ms Within25ms Within100ms Within250ms Within1s Within10s GreaterThan10s AlternatePTPProfile Unknown Reserved

This feature is deprecated (See PtpClockAccuracy). It was used to indicate the expected accuracy of the device clock when it is the grandmaster, or in the event it becomes the grandmaster.

26.4.40 GevIEEE1588Status (Deprecated)

Name	GevIEEE1588Status
Category	GigEVision
Level	Optional
Interface	IEnumeration
Access	Read
Unit	-
Visibility	Invisible
Values	Initializing

	Faulty Disabled Listening PreMaster Master Passive Uncalibrated Slave
--	--

This feature is deprecated (See PtpStatus). It was used to Provide the status of the IEEE 1588 clock.

26.4.41 **GevGVCPExtendedStatusCodesSelector**

Name	GevGVCPExtendedStatusCodesSelector
Category	GigEVision
Level	Optional
Interface	IEnumeration
Access	Read/Write
Unit	-
Visibility	Guru
Values	Version1_1 Version2_0

Selects the GigE Vision version to control extended status codes for.

26.4.42 **GevGVCPExtendedStatusCodes**

Name	GevGVCPExtendedStatusCodes[GevGVCPExtendedStatusCodesSelector]
Category	GigEVision
Level	Optional
Interface	IBoolean
Access	Read/Write
Unit	-
Visibility	Guru
Values	True False

Enables the generation of extended status codes.

26.4.43 **GevGVCPPendingAck**

Name	GevGVCPPendingAck
Category	GigEVision
Level	Optional
Interface	IBoolean
Access	Read/Write
Unit	-
Visibility	Guru
Values	True False

Enables the generation of PENDING_ACK.

26.4.44 **GevGVCPHeartbeatDisable (Deprecated)**

Name	GevGVCPHeartbeatDisable
Category	GigEVision
Level	Optional
Interface	IBoolean
Access	Read/Write
Unit	-
Visibility	Invisible
Values	True False

This feature is deprecated (See DeviceLinkHeartbeatMode). It was used to disable the GVCP heartbeat.

26.4.45 **GevGVCPPendingTimeout (Deprecated)**

Name	GevGVCPPendingTimeout
Category	GigEVision
Level	Optional

Interface	IInteger
Access	Read
Unit	-
Visibility	Invisible
Values	≥ 0

This feature is deprecated (See DeviceLinkCommandTimeout). It was used to indicate the longest GVCP command execution time before a device returns a PENDING_ACK.

26.4.46 **GevPrimaryApplicationSwitchoverKey**

Name	GevPrimaryApplicationSwitchoverKey
Category	GigEVision
Level	Optional
Interface	IInteger
Access	Write-Only
Unit	-
Visibility	Guru
Values	≥ 0

Controls the key to use to authenticate primary application switchover requests.

26.4.47 **GevGVSPExtendedIDMode**

Name	GevGVSPExtendedIDMode
Category	GigEVision
Level	Optional
Interface	IEnumeration
Access	Read/(Write)
Unit	-
Visibility	Expert
Values	Off On

Enables the extended IDs mode.

If the standard IDs mode is not supported, this feature should return On and be read only.
 This feature is not applicable for GigE Vision 1.x devices.

26.4.48 GevCCP

Name	GevCCP
Category	GigE Vision
Level	Optional
Interface	IEnumeration
Access	Read/Write
Unit	-
Visibility	Guru
Values	OpenAccess ExclusiveAccess ControlAccess ControlAccessSwitchoverActive

Controls the device access privilege of an application.

Only one application is allowed to control the device. This application is able to write into device's registers. Other applications can read device's register only if the controlling application does not have the exclusive privilege.

26.4.49 GevPrimaryApplicationSocket

Name	GevPrimaryApplicationSocket
Category	GigE Vision
Level	Optional
Interface	IInteger
Access	Read
Unit	-
Visibility	Guru
Values	≥0

Returns the UDP source port of the primary application.

26.4.50 **GevPrimaryApplicationIPAddress**

Name	GevPrimaryApplicationIPAddress
Category	GigEVision
Level	Optional
Interface	IInteger
Access	Read
Unit	-
Visibility	Guru
Values	≥0

Returns the address of the primary application.

26.4.51 **GevMCPHostPort**

Name	GevMCPHostPort
Category	GigEVision
Level	Optional
Interface	IInteger
Access	Read/Write
Unit	-
Visibility	Guru
Values	≥0

Controls the port to which the device must send messages. Setting this value to 0 closes the message channel.

26.4.52 **GevMCDA**

Name	GevMCDA
Category	GigEVision
Level	Optional
Interface	IInteger
Access	Read/Write
Unit	-

Visibility	Guru
Values	≥ 0

Controls the destination IP address for the message channel.

26.4.53 GevMCTT

Name	GevMCTT
Category	GigEVision
Level	Optional
Interface	IInteger
Access	Read/Write
Unit	ms
Visibility	Guru
Values	> 0

Provides the transmission timeout value in milliseconds.

26.4.54 GevMCRC

Name	GevMCRC
Category	GigEVision
Level	Optional
Interface	IInteger
Access	Read/Write
Unit	-
Visibility	Guru
Values	≥ 0

Controls the number of retransmissions allowed when a message channel message times out.

26.4.55 GevMCSP

Name	GevMCSP
Category	GigEVision
Level	Optional

Interface	IInteger
Access	Read
Unit	-
Visibility	Guru
Values	≥ 0

This feature indicates the source port for the message channel.

26.4.56 **GevStreamChannelSelector**

Name	GevStreamChannelSelector
Category	GigEVision
Level	Optional
Interface	IInteger
Access	Read/Write
Unit	-
Visibility	Expert
Values	≥ 0

Selects the stream channel to control.

26.4.57 **GevSCCFGPacketResendDestination**

Name	GevSCCFGPacketResendDestination[GevStreamChannelSelector]
Category	GigEVision
Level	Optional
Interface	IBoolean
Access	Read/Write
Unit	-
Visibility	Guru
Values	True False

Enables the alternate IP destination for stream packets resent due to a packet resend request. When True, the source IP address provided in the packet resend command packet is used. When False, the value set in the **GevSCDA[GevStreamChannelSelector]** feature is used.

This feature is only valid for GVSP transmitters.

26.4.58 GevSCCFGAllInTransmission

Name	GevSCCFGAllInTransmission[GevStreamChannelSelector]
Category	GigEVision
Level	Optional
Interface	IBoolean
Access	Read/Write
Unit	-
Visibility	Guru
Values	True False

Enables the selected GVSP transmitter to use the single packet per data block All-in Transmission mode.

26.4.59 GevSCCFGUnconditionalStreaming

Name	GevSCCFGUnconditionalStreaming[GevStreamChannelSelector]
Category	GigEVision
Level	Optional
Interface	IBoolean
Access	Read/Write
Unit	-
Visibility	Guru
Values	True False

Enables the camera to continue to stream, for this stream channel, if its control channel is closed or regardless of the reception of any ICMP messages (such as destination unreachable messages).

26.4.60 GevSCCFGExtendedChunkData

Name	GevSCCFGExtendedChunkData[GevStreamChannelSelector]
-------------	---

Category	GigEVision
Level	Optional
Interface	IBoolean
Access	Read/Write
Unit	-
Visibility	Guru
Values	True False

Enables cameras to use the extended chunk data payload type for this stream channel.

26.4.61 **GevSCPDirection (Deprecated)**

Name	GevSCPDirection[GevStreamChannelSelector]
Category	GigEVision
Level	Optional
Interface	IEnumeration
Access	Read
Unit	-
Visibility	Invisible
Values	Transmitter Receiver

This feature is deprecated (See DeviceStreamChannelType). It was used to report the direction of the stream channel.

26.4.62 **GevSCPInterfaceIndex**

Name	GevSCPInterfaceIndex[GevStreamChannelSelector]
Category	GigEVision
Level	Optional
Interface	IInteger
Access	Read/(Write)
Unit	-
Visibility	Guru

Values	0 to 3
---------------	--------

Index of the logical link to use.

Specific streams might be hard-coded to specific logical links. Therefore this field might be read-only on certain devices.

26.4.63 GevSCPHostPort

Name	GevSCPHostPort[GevStreamChannelSelector]
Category	GigEVision
Level	Optional
Interface	IInteger
Access	Read/Write
Unit	-
Visibility	Guru
Values	≥0

Controls the port of the selected channel to which a GVSP transmitter must send data stream or the port from which a GVSP receiver may receive data stream. Setting this value to 0 closes the stream channel.

26.4.64 GevSCPSFireTestPacket

Name	GevSCPSFireTestPacket[GevStreamChannelSelector]
Category	GigEVision
Level	Optional
Interface	IBoolean
Access	Read/Write
Unit	-
Visibility	Guru
Values	True False

Sends a test packet. When this feature is set, the device will fire one test packet.

The "don't fragment" bit of IP header must be set for this test packet.

26.4.65 GevSCPSDoNotFragment

Name	GevSCPSDoNotFragment[GevStreamChannelSelector]
Category	GigEVision
Level	Optional
Interface	IBoolean
Access	Read/Write
Unit	-
Visibility	Guru
Values	True False

The state of this feature is copied into the "do not fragment" bit of IP header of each stream packet. It can be used by the application to prevent IP fragmentation of packets on the stream channel.

26.4.66 GevSCPSBigEndian (Deprecated)

Name	GevSCPSBigEndian[GevStreamChannelSelector]
Category	GigEVision
Level	Optional
Interface	IBoolean
Access	Read/Write
Unit	-
Visibility	Invisible
Values	True False

This feature is deprecated (See DeviceStreamChannelEndianness). It was used to control the endianness of multi-byte pixel data for this stream.

This is an optional feature. A device that does not support this feature must support little-endian and always leave that bit clear.

26.4.67 GevSCPSPacketSize

Name	GevSCPSPacketSize[GevStreamChannelSelector]
Category	GigEVision

Level	Recommended
Interface	IInteger
Access	Read/(Write)
Unit	B
Visibility	Expert
Values	>0

This GigE Vision specific feature corresponds to **DeviceStreamChannelPacketSize** and should be kept in sync with it. It specifies the stream packet size, in bytes, to send on the selected channel for a GVSP transmitter or specifies the maximum packet size supported by a GVSP receiver.

This does not include data leader and data trailer and the last data packet which might be of smaller size (since packet size is not necessarily a multiple of block size for stream channel).

If a device cannot support the requested packet size, then it must not fire a test packet when requested to do so.

26.4.68 **GevSCPD**

Name	GevSCPD[GevStreamChannelSelector]
Category	GigEVision
Level	Recommended
Interface	IInteger
Access	Read/Write
Unit	
Visibility	Expert
Values	≥ 0

Controls the delay (in GEV timestamp counter unit) to insert between each packet for this stream channel. This can be used as a crude flow-control mechanism if the application or the network infrastructure cannot keep up with the packets coming from the device.

26.4.69 **GevSCDA**

Name	GevSCDA[GevStreamChannelSelector]
Category	GigEVision
Level	Optional
Interface	IInteger

Access	Read/Write
Unit	-
Visibility	Guru
Values	≥ 0

Controls the destination IP address of the selected stream channel to which a GVSP transmitter must send data stream or the destination IP address from which a GVSP receiver may receive data stream.

26.4.70 **GevSCSP**

Name	GevSCSP[GevStreamChannelSelector]
Category	GigEVision
Level	Optional
Interface	IInteger
Access	Read
Unit	-
Visibility	Guru
Values	≥ 0

Indicates the source port of the stream channel.

26.4.71 **GevSCZoneCount**

Name	GevSCZoneCount[GevStreamChannelSelector]
Category	GigEVision
Level	Optional
Interface	IInteger
Access	Read
Unit	-
Visibility	Guru
Values	1 to 32

Reports the number of zones per block transmitted on the selected stream channel.

26.4.72 **GevSCZoneDirectionAll**

Name	GevSCZoneDirectionAll[GevStreamChannelSelector]
Category	GigEVision
Level	Optional
Interface	IInteger
Access	Read
Unit	-
Visibility	Guru
Values	00000000h to FFFFFFFFh

Reports the transmission direction of each zone transmitted on the selected stream channel.

This feature is represented as an unsigned integer. The most significant bit of the range of valid values reports the direction of the first zone (Zone ID 0) while the least significant bit represents the direction of the last zone (Zone ID 1).

26.4.73 **GevSCZoneConfigurationLock**

Name	GevSCZoneConfigurationLock[GevStreamChannelSelector]
Category	GigEVision
Level	Optional
Interface	IBoolean
Access	Read/Write
Unit	-
Visibility	Guru
Values	True False

Controls whether the selected stream channel multi-zone configuration is locked. When locked, the GVSP transmitter is not allowed to change the number of zones and their direction during block acquisition and transmission.

26.5 Network Statistics features

This section describes the network statistics specific features.

26.5.1 NetworkStatistics

Name	NetworkStatistics
Category	TransportLayerControl
Level	Optional
Interface	ICategory
Access	Read
Unit	-
Visibility	Guru
Values	-

Category that contains statistics pertaining to various modules of the GigE Vision transport layer.

26.5.2 oMACControlFunctionEntity

Name	oMACControlFunctionEntity
Category	NetworkStatistics
Level	Optional
Interface	ICategory
Access	Read
Unit	-
Visibility	Guru
Values	-

Category that contains statistics pertaining to the MAC control PAUSE function of the device.

When multiple links are aggregated together, this category represents the aggregated statistics of all associated MACs. This is because it is not possible to select each physical network interface in this case.

The counters in this section are defined by the IEEE 802.3 standard. They are generally nonresetable. Rollover behavior and maximum value are device-specific.

26.5.3 aPAUSEMACCtrlFramesTransmitted

Name	aPAUSEMACCtrlFramesTransmitted[GevInterfaceSelector]
Category	oMACControlFunctionEntity
Level	Optional
Interface	IInteger
Access	Read
Unit	-
Visibility	Guru
Values	≥ 0

Reports the number of transmitted PAUSE frames.

26.5.4 aPAUSEMACCtrlFramesReceived

Name	aPAUSEMACCtrlFramesReceived[GevInterfaceSelector]
Category	oMACControlFunctionEntity
Level	Optional
Interface	IInteger
Access	Read
Unit	-
Visibility	Guru
Values	≥ 0

Reports the number of received PAUSE frames.

26.6 Camera Link features

This section describes the Camera Link specific features.

26.6.1 CameraLink

Name	CameraLink
Category	TransportLayerControl

Level	Optional
Interface	ICategory
Access	Read
Unit	-
Visibility	Beginner
Values	-

Category that contains the features pertaining to the Camera Link transport layer of the device. This category is optional especially if the device supports only one transport layer.

26.6.2 CIConfiguration

Name	CIConfiguration
Category	CameraLink
Level	Recommended
Interface	IEnumeration
Access	Read/(Write)
Unit	-
Visibility	Beginner
Values	Base Medium Full DualBase EightyBit Deca (Deprecated)

This Camera Link specific feature describes the configuration used by the camera. It helps especially when a camera is capable of operation in a non-standard configuration, and when the features PixelSize, SensorDigitizationTaps, and DeviceTapGeometry do not provide enough information for interpretation of the image data provided by the camera.

Possible values are:

- **Base:** Standard base configuration described by the Camera Link standard.
- **Medium:** Standard medium configuration described by the Camera Link standard.
- **Full:** Standard full configuration described by the Camera Link standard.

- **DualBase:** The camera streams the data from multiple taps (that do not fit in the standard base configuration) through two Camera Link base ports. It is responsibility of the application or frame grabber to reconstruct the full image. Only one of the ports (fixed) serves as the "master" for serial communication and triggering.
- **EightyBit:** Standard 80-bit configuration with 10 taps of 8 bits or 8 taps of 10 bits, as described by the Camera Link standard.
- **Deca (Deprecated):** This enumeration entry is deprecated. It was used for Deca configuration with 10 taps of 8-bit. Use EightyBit instead.

If the feature is omitted, one of the standard configurations (Base-Medium-Full) is expected. In that case the configuration can be unequivocally deduced from the SensorDigitizationTaps and PixelSize values.

26.6.3 CTimeSlotsCount

Name	CITimeSlotsCount
Category	CameraLink
Level	Optional
Interface	IEnumeration
Access	Read/(Write)
Unit	-
Visibility	Expert
Values	One Two Three

This Camera Link specific feature describes the time multiplexing of the camera link connection to transfer more than the configuration allows, in one single clock.

Possible values are:

- **One:** One time slot.
- **Two:** Two time slots.
- **One:** Three time slots.

It indicates the number of consecutive time slots required to transfer one data of each tap.

26.7 CoaXPress features

This section describes the CoaXPress specific features.

26.7.1 CoaXPress

Name	CoaXPress
Category	TransportLayerControl
Level	Optional
Interface	ICategory
Access	Read
Unit	-
Visibility	Beginner
Values	-

Category that contains the features pertaining to the CoaXPress transport layer of the device.

26.7.2 CxpLinkConfigurationStatus

Name	CxpLinkConfigurationStatus
Category	CoaXPress
Level	Recommended
Interface	IEnumeration
Access	Read
Unit	-
Visibility	Beginner
Values	None Pending CXP1_X1 CXP2_X1 CXP3_X1 CXP5_X1 CXP6_X1 CXP10_X1 CXP12_X1 CXP1_X2 CXP2_X2 CXP3_X2 CXP5_X2 CXP6_X2 CXP10_X2 CXP12_X2 CXP1_X3

	CXP2_X3
	CXP3_X3
	CXP5_X3
	CXP6_X3
	CXP10_X3
	CXP12_X3
	CXP1_X4
	CXP2_X4
	CXP3_X4
	CXP5_X4
	CXP6_X4
	CXP10_X4
	CXP12_X4
	CXP1_X5
	CXP2_X5
	CXP3_X5
	CXP5_X5
	CXP6_X5
	CXP10_X5
	CXP12_X5
	CXP1_X6
	CXP2_X6
	CXP3_X6
	CXP5_X6
	CXP6_X6
	CXP10_X6
	CXP12_X6

This feature indicates the current and active Link configuration used by the Device.

When the Link is active, this feature returns the Link configuration as the combination of the Connection speed and the number of active Connections using the following format "CXP m _X n ", where m is the Connection speed and n the number of active Connections. For example "CXP6_X4" means 4 connections are operating at CXP-6 speed (6.25 Gbps) so the total speed on the virtual single link is 25 Gbps.

Possible values are:

- **None:** The Link configuration of the Device is unknown. Either the configuration operation has failed or there is nothing connected.
- **Pending:** The Device is in the process of configuring the Link. The Link cannot be used yet.
- **CXP1_X1:** 1 Connection operating at CXP-1 speed (1.25 Gbps).
- **CXP2_X1:** 1 Connection operating at CXP-2 speed (2.50 Gbps).
- **CXP3_X1:** 1 Connection operating at CXP-3 speed (3.125 Gbps).
- **CXP5_X1:** 1 Connection operating at CXP-5 speed (5.00 Gbps).

- **CXP6_X1**: 1 Connection operating at CXP-6 speed (6.25 Gbps).
- **CXP10_X1**: 1 Connection operating at CXP-10 speed (10.00 Gbps).
- **CXP12_X1**: 1 Connection operating at CXP-12 speed (12.50 Gbps).
- **CXP1_X2**: 2 Connections operating at CXP-1 speed (1.25 Gbps).
- **CXP2_X2**: 2 Connections operating at CXP-2 speed (2.50 Gbps).
- **CXP3_X2**: 2 Connections operating at CXP-3 speed (3.125 Gbps).
- **CXP5_X2**: 2 Connections operating at CXP-5 speed (5.00 Gbps).
- **CXP6_X2**: 2 Connections operating at CXP-6 speed (6.25 Gbps).
- **CXP10_X2**: 2 Connections operating at CXP-10 speed (10.00 Gbps).
- **CXP12_X2**: 2 Connections operating at CXP-12 speed (12.50 Gbps).
- **CXP1_X3**: 3 Connections operating at CXP-1 speed (1.25 Gbps).
- **CXP2_X3**: 3 Connections operating at CXP-2 speed (2.50 Gbps).
- **CXP3_X3**: 3 Connections operating at CXP-3 speed (3.125 Gbps).
- **CXP5_X3**: 3 Connections operating at CXP-5 speed (5.00 Gbps).
- **CXP6_X3**: 3 Connections operating at CXP-6 speed (6.25 Gbps).
- **CXP10_X3**: 3 Connections operating at CXP-10 speed (10.00 Gbps).
- **CXP12_X3**: 3 Connections operating at CXP-12 speed (12.50 Gbps).
- **CXP1_X4**: 4 Connections operating at CXP-1 speed (1.25 Gbps).
- **CXP2_X4**: 4 Connections operating at CXP-2 speed (2.50 Gbps).
- **CXP3_X4**: 4 Connections operating at CXP-3 speed (3.125 Gbps).
- **CXP5_X4**: 4 Connections operating at CXP-5 speed (5.00 Gbps).
- **CXP6_X4**: 4 Connections operating at CXP-6 speed (6.25 Gbps).
- **CXP10_X4**: 4 Connections operating at CXP-10 speed (10.00 Gbps).
- **CXP12_X4**: 4 Connections operating at CXP-12 speed (12.50 Gbps).
- **CXP1_X5**: 5 Connections operating at CXP-1 speed (1.25 Gbps).
- **CXP2_X5**: 5 Connections operating at CXP-2 speed (2.50 Gbps).
- **CXP3_X5**: 5 Connections operating at CXP-3 speed (3.125 Gbps).
- **CXP5_X5**: 5 Connections operating at CXP-5 speed (5.00 Gbps).
- **CXP6_X5**: 5 Connections operating at CXP-6 speed (6.25 Gbps).
- **CXP10_X5**: 5 Connections operating at CXP-10 speed (10.00 Gbps).
- **CXP12_X5**: 5 Connections operating at CXP-12 speed (12.50 Gbps).

- **CXP1_X6:** 6 Connections operating at CXP-1 speed (1.25 Gbps).
- **CXP2_X6:** 6 Connections operating at CXP-2 speed (2.50 Gbps).
- **CXP3_X6:** 6 Connections operating at CXP-3 speed (3.125 Gbps).
- **CXP5_X6:** 6 Connections operating at CXP-5 speed (5.00 Gbps).
- **CXP6_X6:** 6 Connections operating at CXP-6 speed (6.25 Gbps).
- **CXP10_X6:** 6 Connections operating at CXP-10 speed (10.00 Gbps).
- **CXP12_X6:** 6 Connections operating at CXP-12 speed (12.50 Gbps).

26.7.3 CxpLinkConfigurationPreferred

Name	CxpLinkConfigurationPreferred
Category	CoaXPress
Level	Recommended
Interface	IEnumeration
Access	Read
Unit	-
Visibility	Expert
Values	CXP1_X1 CXP2_X1 CXP3_X1 CXP5_X1 CXP6_X1 CXP10_X1 CXP12_X1 CXP1_X2 CXP2_X2 CXP3_X2 CXP5_X2 CXP6_X2 CXP10_X2 CXP12_X2 CXP1_X3 CXP2_X3 CXP3_X3 CXP5_X3 CXP6_X3 CXP10_X3 CXP12_X3

CXP1_X4
CXP2_X4
CXP3_X4
CXP5_X4
CXP6_X4
CXP10_X4
CXP12_X4
CXP1_X5
CXP2_X5
CXP3_X5
CXP5_X5
CXP6_X5
CXP10_X5
CXP12_X5
CXP1_X6
CXP2_X6
CXP3_X6
CXP5_X6
CXP6_X6
CXP10_X6
CXP12_X6

Provides the Link configuration that allows the Transmitter Device to operate in its default mode.

The Link configuration is returned as the combination of the Connection speed and the number of active Connections using the following format "CXP m _X n ", where m is the Connection speed and n the number of active Connections.

Possible values are:

- **CXP1_X1**: 1 Connection operating at CXP-1 speed (1.25 Gbps).
- **CXP2_X1**: 1 Connection operating at CXP-2 speed (2.50 Gbps).
- **CXP3_X1**: 1 Connection operating at CXP-3 speed (3.125 Gbps).
- **CXP5_X1**: 1 Connection operating at CXP-5 speed (5.00 Gbps).
- **CXP6_X1**: 1 Connection operating at CXP-6 speed (6.25 Gbps).
- **CXP10_X1**: 1 Connection operating at CXP-10 speed (10.00 Gbps).
- **CXP12_X1**: 1 Connection operating at CXP-12 speed (12.50 Gbps).
- **CXP1_X2**: 2 Connections operating at CXP-1 speed (1.25 Gbps).
- **CXP2_X2**: 2 Connections operating at CXP-2 speed (2.50 Gbps).
- **CXP3_X2**: 2 Connections operating at CXP-3 speed (3.125 Gbps).
- **CXP5_X2**: 2 Connections operating at CXP-5 speed (5.00 Gbps).

- **CXP6_X2**: 2 Connections operating at CXP-6 speed (6.25 Gbps).
- **CXP10_X2**: 2 Connections operating at CXP-10 speed (10.00 Gbps).
- **CXP12_X2**: 2 Connections operating at CXP-12 speed (12.50 Gbps).
- **CXP1_X3**: 3 Connections operating at CXP-1 speed (1.25 Gbps).
- **CXP2_X3**: 3 Connections operating at CXP-2 speed (2.50 Gbps).
- **CXP3_X3**: 3 Connections operating at CXP-3 speed (3.125 Gbps).
- **CXP5_X3**: 3 Connections operating at CXP-5 speed (5.00 Gbps).
- **CXP6_X3**: 3 Connections operating at CXP-6 speed (6.25 Gbps).
- **CXP10_X3**: 3 Connections operating at CXP-10 speed (10.00 Gbps).
- **CXP12_X3**: 3 Connections operating at CXP-12 speed (12.50 Gbps).
- **CXP1_X4**: 4 Connections operating at CXP-1 speed (1.25 Gbps).
- **CXP2_X4**: 4 Connections operating at CXP-2 speed (2.50 Gbps).
- **CXP3_X4**: 4 Connections operating at CXP-3 speed (3.125 Gbps).
- **CXP5_X4**: 4 Connections operating at CXP-5 speed (5.00 Gbps).
- **CXP6_X4**: 4 Connections operating at CXP-6 speed (6.25 Gbps).
- **CXP10_X4**: 4 Connections operating at CXP-10 speed (10.00 Gbps).
- **CXP12_X4**: 4 Connections operating at CXP-12 speed (12.50 Gbps).
- **CXP1_X5**: 5 Connections operating at CXP-1 speed (1.25 Gbps).
- **CXP2_X5**: 5 Connections operating at CXP-2 speed (2.50 Gbps).
- **CXP3_X5**: 5 Connections operating at CXP-3 speed (3.125 Gbps).
- **CXP5_X5**: 5 Connections operating at CXP-5 speed (5.00 Gbps).
- **CXP6_X5**: 5 Connections operating at CXP-6 speed (6.25 Gbps).
- **CXP10_X5**: 5 Connections operating at CXP-10 speed (10.00 Gbps).
- **CXP12_X5**: 5 Connections operating at CXP-12 speed (12.50 Gbps).
- **CXP1_X6**: 6 Connections operating at CXP-1 speed (1.25 Gbps).
- **CXP2_X6**: 6 Connections operating at CXP-2 speed (2.50 Gbps).
- **CXP3_X6**: 6 Connections operating at CXP-3 speed (3.125 Gbps).
- **CXP5_X6**: 6 Connections operating at CXP-5 speed (5.00 Gbps).
- **CXP6_X6**: 6 Connections operating at CXP-6 speed (6.25 Gbps).
- **CXP10_X6**: 6 Connections operating at CXP-10 speed (10.00 Gbps).
- **CXP12_X6**: 6 Connections operating at CXP-12 speed (12.50 Gbps).

26.7.4 CxpLinkConfiguration

Name	CxpLinkConfiguration
Category	CoaXPress
Level	Recommended
Interface	IEnumeration
Access	Read/Write
Unit	-
Visibility	Beginner
Values	Auto CXP1_X1 CXP2_X1 CXP3_X1 CXP5_X1 CXP6_X1 CXP10_X1 CXP12_X1 CXP1_X2 CXP2_X2 CXP3_X2 CXP5_X2 CXP6_X2 CXP10_X2 CXP12_X2 CXP1_X3 CXP2_X3 CXP3_X3 CXP5_X3 CXP6_X3 CXP10_X3 CXP12_X3 CXP1_X4 CXP2_X4 CXP3_X4 CXP5_X4 CXP6_X4 CXP10_X4 CXP12_X4 CXP1_X5

	CXP2_X5 CXP3_X5 CXP5_X5 CXP6_X5 CXP10_X5 CXP12_X5 CXP1_X6 CXP2_X6 CXP3_X6 CXP5_X6 CXP6_X6 CXP10_X6 CXP12_X6
--	---

This feature allows specifying the Link configuration for the communication between the Receiver and Transmitter Device. In most cases this feature does not need to be written because automatic discovery will set configuration correctly to the value returned by `CxpLinkConfigurationPreferred`. Note that the currently active configuration of the Link can be read using `CxpLinkConfigurationStatus`.

The Link configuration is specified as the combination of the Connection speed and the number of active Connections using the following format "`CXP m _X n` ", where m is the Connection speed and n the number of active Connections. Selecting Auto sets the Link to normal, automatic, discovery, as described in the CoaXPress standard. The Receiver Device will automatically discover any Transmitter Device connected from then on.

Possible values are:

- **Auto**: Sets Automatic discovery for the Link Configuration.
- **CXP1_X1**: Force the Link to 1 Connection operating at CXP-1 speed (1.25 Gbps).
- **CXP2_X1**: Force the Link to 1 Connection operating at CXP-2 speed (2.50 Gbps).
- **CXP3_X1**: Force the Link to 1 Connection operating at CXP-3 speed (3.125 Gbps).
- **CXP5_X1**: Force the Link to 1 Connection operating at CXP-5 speed (5.00 Gbps).
- **CXP6_X1**: Force the Link to 1 Connection operating at CXP-6 speed (6.25 Gbps).
- **CXP10_X1**: Force the Link to 1 Connection operating at CXP-10 speed (10.00 Gbps).
- **CXP12_X1**: Force the Link to 1 Connection operating at CXP-12 speed (12.50 Gbps).
- **CXP1_X2**: Force the Link to 2 Connections operating at CXP-1 speed (1.25 Gbps).
- **CXP2_X2**: Force the Link to 2 Connections operating at CXP-2 speed (2.50 Gbps).
- **CXP3_X2**: Force the Link to 2 Connections operating at CXP-3 speed (3.125 Gbps).
- **CXP5_X2**: Force the Link to 2 Connections operating at CXP-5 speed (5.00 Gbps).
- **CXP6_X2**: Force the Link to 2 Connections operating at CXP-6 speed (6.25 Gbps).

- **CXP10_X2**: Force the Link to 2 Connections operating at CXP-10 speed (10.00 Gbps).
- **CXP12_X2**: Force the Link to 2 Connections operating at CXP-12 speed (12.50 Gbps).
- **CXP1_X3**: Force the Link to 3 Connections operating at CXP-1 speed (1.25 Gbps).
- **CXP2_X3**: Force the Link to 3 Connections operating at CXP-2 speed (2.50 Gbps).
- **CXP3_X3**: Force the Link to 3 Connections operating at CXP-3 speed (3.125 Gbps).
- **CXP5_X3**: Force the Link to 3 Connections operating at CXP-5 speed (5.00 Gbps).
- **CXP6_X3**: Force the Link to 3 Connections operating at CXP-6 speed (6.25 Gbps).
- **CXP10_X3**: Force the Link to 3 Connections operating at CXP-10 speed (10.00 Gbps).
- **CXP12_X3**: Force the Link to 3 Connections operating at CXP-12 speed (12.50 Gbps).
- **CXP1_X4**: Force the Link to 4 Connections operating at CXP-1 speed (1.25 Gbps).
- **CXP2_X4**: Force the Link to 4 Connections operating at CXP-2 speed (2.50 Gbps).
- **CXP3_X4**: Force the Link to 4 Connections operating at CXP-3 speed (3.125 Gbps).
- **CXP5_X4**: Force the Link to 4 Connections operating at CXP-5 speed (5.00 Gbps).
- **CXP6_X4**: Force the Link to 4 Connections operating at CXP-6 speed (6.25 Gbps).
- **CXP10_X4**: Force the Link to 4 Connections operating at CXP-10 speed (10.00 Gbps).
- **CXP12_X4**: Force the Link to 4 Connections operating at CXP-12 speed (12.50 Gbps).
- **CXP1_X5**: Force the Link to 5 Connections operating at CXP-1 speed (1.25 Gbps).
- **CXP2_X5**: Force the Link to 5 Connections operating at CXP-2 speed (2.50 Gbps).
- **CXP3_X5**: Force the Link to 5 Connections operating at CXP-3 speed (3.125 Gbps).
- **CXP5_X5**: Force the Link to 5 Connections operating at CXP-5 speed (5.00 Gbps).
- **CXP6_X5**: Force the Link to 5 Connections operating at CXP-6 speed (6.25 Gbps).
- **CXP10_X5**: Force the Link to 5 Connections operating at CXP-10 speed (10.00 Gbps).
- **CXP12_X5**: Force the Link to 5 Connections operating at CXP-12 speed (12.50 Gbps).
- **CXP1_X6**: Force the Link to 6 Connections operating at CXP-1 speed (1.25 Gbps).
- **CXP2_X6**: Force the Link to 6 Connections operating at CXP-2 speed (2.50 Gbps).
- **CXP3_X6**: Force the Link to 6 Connections operating at CXP-3 speed (3.125 Gbps).
- **CXP5_X6**: Force the Link to 6 Connections operating at CXP-5 speed (5.00 Gbps).
- **CXP6_X6**: Force the Link to 6 Connections operating at CXP-6 speed (6.25 Gbps).
- **CXP10_X6**: Force the Link to 6 Connections operating at CXP-10 speed (10.00 Gbps).
- **CXP12_X6**: Force the Link to 6 Connections operating at CXP-12 speed (12.50 Gbps).

26.7.5 CxpConnectionSelector

Name	CxpConnectionSelector
Category	CoaXPress
Level	Recommended
Interface	IInteger
Access	Read/Write
Unit	-
Visibility	Expert
Values	≥ 0

Selects the CoaXPress physical connection to control.

Note that this selector should be set to 0, or omitted, when controlling features relating to the CoaXPress uplink from the Receiver Device to the Transmitter Device, because only one connection 0 is used for this purpose.

26.7.6 CxpConnectionTestMode

Name	CxpConnectionTestMode[CxpConnectionSelector]
Category	CoaXPress
Level	Recommended
Interface	IEnumeration
Access	Read/Write
Unit	-
Visibility	Expert
Values	Off Mode1

Enables the test mode for an individual physical connection of the Device.

Possible values are:

- **Off:** Test mode is disabled.
- **Mode1:** Test mode is one.

This can be used to test communication errors of the system cabling between devices.

When enabled, this feature results in special test packets being sent continuously by the Device on the connection specified by CxpConnectionSelector.

The Device receiving the test packet on the other end of the connection can check for errors by reading its own corresponding CxpConnectionTestErrorCount and CxpConnectionTestPacketCount features.

Typically, the test will need to be run for some time (e.g. minutes) to get a meaningful error rate.

26.7.7 CxpConnectionTestErrorCount

Name	CxpConnectionTestErrorCount[CxpConnectionSelector]
Category	CoaXPress
Level	Recommended
Interface	IInteger
Access	Read/Write
Unit	-
Visibility	Expert
Values	≥ 0

Reports the current connection error count for test packets received by the device on the connection selected by CxpConnectionSelector.

The transmission of those test packets is enabled by the CxpConnectionTestMode feature of the Device on the other end of the connection under test.

This feature can be read at any time while a test is running. It can be written to zero when a test is not running to reset the counter between tests.

26.7.8 CxpConnectionTestPacketCount

Name	CxpConnectionTestPacketCount[CxpConnectionSelector]
Category	CoaXPress
Level	Recommended
Interface	IInteger
Access	Read/Write
Unit	-
Visibility	Expert
Values	≥ 0

Reports the current count for test packets received by the device on the connection selected by CxpConnectionSelector.

The transmission of those test packets is enabled by the CxpConnectionTestMode feature of the Device on the other end of the connection under test.

This feature can be read at any time while a test is running. It can be written to zero when the test is not running to reset the counter between tests.

26.7.9 CxpPoCxpAuto

Name	CxpPoCxpAuto
Category	CoaXPress
Level	Optional
Interface	ICommand
Access	Write
Unit	-
Visibility	Expert
Values	-

Activate automatic control of the Power over CoaXPress (PoCXP) for the Link.

This feature shall be present only on receiver or transceiver Devices controlling PoCXP.

26.7.10 CxpPoCxpTurnOff

Name	CxpPoCxpTurnOff
Category	CoaXPress
Level	Optional
Interface	ICommand
Access	Write
Unit	-
Visibility	Expert
Values	-

Disable Power over CoaXPress (PoCXP) for the Link.

This feature shall be present only on receiver or transceiver Devices controlling PoCXP.

26.7.11 CxpPoCxpTripReset

Name	CxpPoCxpTripReset
Category	CoaXPress
Level	Optional
Interface	ICommand
Access	Write
Unit	-
Visibility	Expert
Values	-

Reset the Power over CoaXPress (PoCXP) Link after an over-current trip on the Device connection(s).

This feature shall be present only on receiver or transceiver Devices controlling PoCXP.

26.7.12 CxpPoCxpStatus

Name	CxpPoCxpStatus
Category	CoaXPress
Level	Optional
Interface	IEnumeration
Access	Read
Unit	-
Visibility	Expert
Values	Auto Off Tripped

Returns the Power over CoaXPress (PoCXP) status of the Device.

Possible values are:

- **Auto:** Normal automatic PoCXP operation.
- **Off:** PoCXP is forced off.
- **Tripped:** The Link has shut down because of an over-current trip.

This feature shall be present only on Receiver Device that controls the PoCXP.

27 Acknowledgements

The following companies have participated in the elaboration of the GenICam Standard Features Naming Convention:

Company	Represented by
Teledyne DALSA	Eric Carey, Eric Bourbonnais
STEMMER IMAGING	Sascha Dorenbeck, Rupert Stelz
SICK IVP	Mattias Johannesson
Pleora Technologies	Francois Gobeil, Vincent Rowley, Geoff Roddick
Point Grey	Damian Nesbitt
National Instruments	Eric Gross
MVTec Software	Christoph Zierl, Thomas Hopfner
Matrox Imaging	Stéphane Maurice
MATRIX VISION	Stefan Battmer
MathWorks	Mark Jones
Leutron Vision	Stefan Thommen
JAI	Karsten Ingeman Christensen
Groget	Jan Becvar
Euresys	Jean-Michel Wintgens
Basler	Fritz Dierks, Thies Möller, Alex Happe, Andreas Gaer, Sven Seeger
Baumer	Marcel Naggatz
AVAL DATA	Masahide Matsubara
Automation Technology	Stephan Kieneke
Allied Vision	Holger Eddelbuettel

28 Tap Geometry Appendix

28.1 Motivations

This appendix defines standard names to uniquely identify the geometrical properties of most device's sensor taps.

For example, the initial release of the Camera Link® standard didn't include any information about the geometrical properties of taps.

Frame grabbers are able to reconstruct the image from multi-tap cameras on-the-fly.

Camera manufacturers should clearly specify what geometry(ies) is (are) required. Frame grabber manufacturers should also clearly specify what geometry(ies) is (are) supported.

The customer can then check the compatibility, and select the appropriate geometry for the camera and the frame grabber.

Considering the limited amount of cases, a unique name is assigned for each geometry.

28.2 Identifying the Geometrical Properties

28.2.1 Image Geometrical Properties

The relevant geometrical properties required for reconstructing the image:

- **Vantage point:** An enumerated value that specifies the position of the pixel with coordinate X=1, Y=1 in the scene.
{Top-Left, Top-Right, Bottom-Left, Bottom-Right}
Default is Top-Left.
- **ImageWidth:** An integer value declaring the image width expressed in pixels.
- **ImageHeight:** An integer value declaring the image height expressed in pixels.
This parameter is irrelevant in case of line-scan or TDI cameras.
- **TapGeometry:** An enumerated type of parameter that summarizes the following properties for each tap:
 - XStart: X-coordinate of the first pixel column
 - YStart: Y-coordinate of the first pixel row
 - XEnd: X-coordinate of the last pixel column
 - YEnd: Y-coordinate of the last pixel row
 - XStep: Difference of X-coordinates between consecutive pixel columns; X-step is positive when X-coordinates are increasing along a row; it is negative otherwise.

- YStep: Difference of Y-coordinates between consecutive pixel rows; Y-step is positive when Y-coordinates is increasing at the end of a line; it is negative otherwise.
- Allocation of taps to ports. The camera taps are indexed using following conventional sorting rule:
First by increasing values of YStart then by increasing value of XStart. The tap T1 is the sensor tap that exhibits the smallest XStart for the smallest YStart.

28.2.1.1 Restrictions

- All zones have the same size.
- Zones do not overlap.
- All zones have the same number of taps.
- All taps are carrying the same amount of pixels.

28.2.1.2 Tap Naming Convention

A tap configuration for **area-scan** camera is designated by:

`<TapGeometryX>-<TapGeometryY>`

A tap configuration for **line-scan or TDI-line-scan** camera is designated by:

`<TapGeometryX>`

TapGeometryX is designated by `<ZoneX>X(<TapX>)(<ExtX>)`

`<ZoneX>`: An integer in the range of {1, 2, 3, 4, 8, 10} declaring number of zones encountered across horizontal direction.

`<TapX>`: An integer in range {∅, 2, 3, 4, 8, 10} declaring the number of consecutive pixels in the horizontal direction that are outputted simultaneously from a zone. This field is omitted when all pixels are in the same column.

`<ExtX>`: A letter in the range of {∅, E, M} declaring the location of the pixels extractors in the horizontal direction. The value E indicates that pixel extractors are at both ends of the line. Value M indicates that pixel extractors are in the middle of the line. This field is omitted when all pixel extractors are all at the left end of each zone.

TapGeometryY is designated by `<ZoneY>Y(<TapY>)(<ExtY>)`

`<ZoneY>`: An integer in the range of {1, 2} declaring the number of zones encountered in the vertical direction.

<TapY>: An integer in the range of $\{\emptyset, 2\}$ declaring the number of consecutive pixels in vertical direction that are outputted simultaneously from each zone. This field is omitted when all pixels are in the same line.

<ExtY>: A letter in range of $\{\emptyset, E\}$ declaring the location of the pixels extractors in the vertical direction. The value E indicates that pixel extractors are at both top and bottom lines. This field is omitted when all pixel extractors are in the top line.

28.2.1.3 Tap Geometrical Properties

The following tables provide description of all the tap geometry configurations. For every configuration the first and last pixel belonging to that tap, as well as the pixel increment corresponding to the given tap is listed.

This table enumerates the standard tap geometries. The table is sorted by increasing number of taps. It displays the values of the 6 geometrical properties for each tap.

Table 28-1 Tap geometrical properties – One, two and three taps

Geometry name		Tap	Tap geometrical properties					
Area-scan	Line-scan		X Start	X End	Step X	Y Start	Y End	Step Y
1X-1Y	1X	Tap1	1	W	1	1	H	1
1X2-1Y	1X2	Tap1	1	W-1	2	1	H	1
		Tap2	2	W	2	1	H	1
2X-1Y	2X	Tap1	1	W/2	1	1	H	1
		Tap2	W/2+1	W	1	1	H	1
2XE-1Y	2XE	Tap1	1	W/2	1	1	H	1
		Tap2	W	W/2+1	-1	1	H	1
2XM-1Y	2XM	Tap1	W/2	1	-1	1	H	1
		Tap2	W/2+1	W	1	1	H	1
1X-1Y2		Tap1	1	W	1	1	H-1	2
		Tap2	1	W	1	2	H	2
1X-2YE		Tap1	1	W	1	1	H/2	1
		Tap2	1	W	1	H	H/2+1	-1
1X3-1Y	1X3	Tap1	1	W-2	3	1	H	1
		Tap2	2	W-1	3	1	H	1
		Tap3	3	W	3	1	H	1
3X-1Y	3X	Tap1	1	W/3	1	1	H	1
		Tap2	W/3+1	2W/3	1	1	H	1
		Tap3	2W/3+1	W	1	1	H	1

Table 28-2 Tap geometrical properties – Four taps

Geometry name		Tap	Tap geometrical properties					
Area-scan	Line-scan		X Start	X End	Step X	Y Start	Y End	Step Y
1X4-1Y	1X4	Tap1	1	W-3	4	1	H	1
		Tap2	2	W-2	4	1	H	1
		Tap3	3	W-1	4	1	H	1
		Tap4	4	W	4	1	H	1
4X-1Y	4X	Tap1	1	W/4	1	1	H	1
		Tap2	W/4+1	W/2	1	1	H	1
		Tap3	W/2+1	3W/4	1	1	H	1
		Tap4	3W/4+1	W	1	1	H	1
2X2-1Y	2X2	Tap1	1	W/2-1	2	1	H	1
		Tap2	2	W/2	2	1	H	1
		Tap3	W/2+1	W-1	2	1	H	1
		Tap4	W/2+2	W	2	1	H	1
2X2E-1Y	2X2E	Tap1	1	W/2-1	2	1	H	1
		Tap2	2	W/2	2	1	H	1
		Tap3	W-1	W/2+1	-2	1	H	1
		Tap4	W	W/2+2	-2	1	H	1
2X2M-1Y	2X2M	Tap1	W/2-1	1	-2	1	H	1
		Tap2	W/2	2	-2	1	H	1
		Tap3	W/2+1	W-1	2	1	H	1
		Tap4	W/2+2	W	2	1	H	1
1X2-2YE		Tap1	1	W-1	2	1	H/2	1
		Tap2	2	W	2	1	H/2	1
		Tap3	1	W-1	2	H	H/2+1	-1
		Tap4	2	W	2	H	H/2+1	-1
1X2-1Y2		Tap1	1	W-1	2	1	H-1	2
		Tap2	2	W	2	1	H-1	2
		Tap3	1	W-1	2	2	H	2
		Tap4	2	W	2	2	H	2
2X-2YE		Tap1	1	W/2	1	1	H/2	1
		Tap2	W/2+1	W	1	1	H/2	1
		Tap3	1	W/2	1	H	H/2+1	-1
		Tap4	W/2+1	W	1	H	H/2+1	-1
2X-1Y2		Tap1	1	W/2	1	1	H-1	2
		Tap2	W/2+1	W	1	1	H-1	2
		Tap3	1	W/2	1	2	H	2
		Tap4	W/2+1	W	1	2	H	2
2XE-2YE		Tap1	1	W/2	1	1	H/2	1
		Tap2	W	W/2+1	-1	1	H/2	1
		Tap3	1	W/2	1	H	H/2+1	-1

Geometry name		Tap	Tap geometrical properties					
Area-scan	Line-scan		X Start	X End	Step X	Y Start	Y End	Step Y
		Tap4	W	W/2+1	-1	H	H/2+1	-1
2XE-1Y2		Tap1	1	W/2	1	1	H-1	2
		Tap2	W	W/2+1	-1	1	H-1	2
		Tap3	1	W/2	1	2	H	2
		Tap4	W	W/2+1	-1	2	H	2
2XM-2YE		Tap1	W/2	1	-1	1	H/2	1
		Tap2	W/2+1	W	1	1	H/2	1
		Tap3	W/2	1	-1	H	H/2+1	-1
		Tap4	W/2+1	W	1	H	H/2+1	-1
2XM-1Y2		Tap1	W/2	1	-1	1	H-1	2
		Tap2	W/2+1	W	1	1	H-1	2
		Tap3	W/2	1	-1	2	H	2
		Tap4	W/2+1	W	1	2	H	2

Table 28-3 Tap geometrical properties –Eight taps

Geometry name		Tap	Tap geometrical properties					
Area-scan	Line-scan		X Start	X End	Step X	Y Start	Y End	Step Y
1X8-1Y	1X8	Tap1	1	W-7	8	1	H	1
		Tap2	2	W-6	8	1	H	1
		Tap3	3	W-5	8	1	H	1
		Tap4	4	W-4	8	1	H	1
		Tap5	5	W-3	8	1	H	1
		Tap6	6	W-2	8	1	H	1
		Tap7	7	W-1	8	1	H	1
		Tap8	8	W	8	1	H	1
8X-1Y	8X	Tap1	1	W/8	1	1	H	1
		Tap2	W/8+1	2W/8	1	1	H	1
		Tap3	2W/8+1	3W/8	1	1	H	1
		Tap4	3W/8+1	4W/8	1	1	H	1
		Tap5	4W/8+1	5W/8	1	1	H	1
		Tap6	5W/8+1	6W/8	1	1	H	1
		Tap7	6W/8+1	7W/8	1	1	H	1
		Tap8	7W/8+1	W	1	1	H	1
4X2-1Y	4X2	Tap1	1	W/4-1	2	1	H	1
		Tap2	2	W/4	2	1	H	1
		Tap3	W/4+1	W/2-1	2	1	H	1
		Tap4	W/4+1	W/2	2	1	H	1
		Tap5	W/2+1	3W/4-1	2	1	H	1
		Tap6	W/2+2	3W/4	2	1	H	1
		Tap7	3W/4+1	W-1	2	1	H	1
		Tap8	3W/4+2	W	2	1	H	1
4X2E-1Y	4X2E	Tap1	1	W/4-1	2	1	H	1
		Tap2	2	W/4	2	1	H	1
		Tap3	W/4+1	W/2-1	2	1	H	1
		Tap4	W/4+2	W/2	2	1	H	1
		Tap5	3W/4-1	W/2+1	-2	1	H	1
		Tap6	3W/4	W/2+2	-2	1	H	1
		Tap7	W-1	3W/4+1	-2	1	H	1
		Tap8	W	3W/4+2	-2	1	H	1
2X2E-2YE		Tap1	1	W/2-1	2	1	H/2	1
		Tap2	2	W/2	2	1	H/2	1
		Tap3	W-1	W/2+1	-2	1	H/2	1
		Tap4	W	W/2+2	-2	1	H/2	1
		Tap5	1	W/2-1	2	H	H/2+1	-1
		Tap6	2	W/2	2	H	H/2+1	-1

Geometry name		Tap	Tap geometrical properties					
Area-scan	Line-scan		X Start	X End	Step X	Y Start	Y End	Step Y
		Tap7	$W-1$	$W/2+1$	-2	H	$H/2+1$	-1
		Tap8	W	$W/2+2$	-2	H	$H/2+1$	-1

Table 28-4 Tap geometrical properties –Ten taps

Geometry name		Tap	Tap geometrical properties					
Area-scan	Line-scan		X Start	X End	Step X	Y Start	Y End	Step Y
1X10-1Y	1X10	Tap1	1	W-9	10	1	H	1
		Tap2	2	W-8	10	1	H	1
		Tap3	3	W-7	10	1	H	1
		Tap4	4	W-6	10	1	H	1
		Tap5	5	W-5	10	1	H	1
		Tap6	6	W-4	10	1	H	1
		Tap7	7	W-3	10	1	H	1
		Tap8	8	W-2	10	1	H	1
		Tap9	9	W-1	10	1	H	1
		Tap10	10	W	10	1	H	1
10X-1Y	10X	Tap1	1	W/10	1	1	H	1
		Tap2	W/10+1	2W/10	1	1	H	1
		Tap3	2W/10+1	3W/10	1	1	H	1
		Tap4	3W/10+1	4W/10	1	1	H	1
		Tap5	4W/10+1	5W/10	1	1	H	1
		Tap6	5W/10+1	6W/10	1	1	H	1
		Tap7	6W/10+1	7W/10	1	1	H	1
		Tap8	7W/10+1	8W/10	1	1	H	1
		Tap9	8W/10+1	9W/10	1	1	H	1
		Tap10	9W/10+1	W	1	1	H	1

28.3 Tap Geometry Drawings

28.3.1 Single Tap Geometry

1X-1Y (area-scan)

1 zone in X, 1 zone in Y.

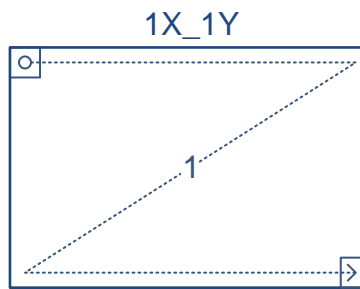

Figure 28-1: Geometry 1X-1Y (area-scan)

1X (line-scan)

1 zone in X.



Figure 28-2: Geometry 1X (line-scan)

28.3.2 Dual Tap Geometries

1X2-1Y (area-scan)

1 zone in X with 2 taps, 1 zone in Y.

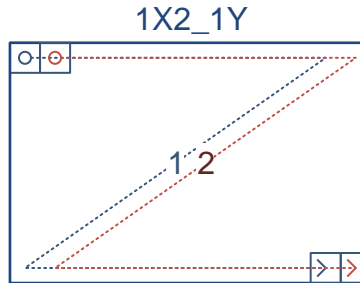

Figure 28-3: Geometry 1X2-1Y (area-scan)

1X2 (line-scan)

1 zone in X with 2 taps.



Figure 28-4: Geometry 1X2 (line-scan)

2X-1Y (area-scan)

2 zones in X, 1 zone in Y.

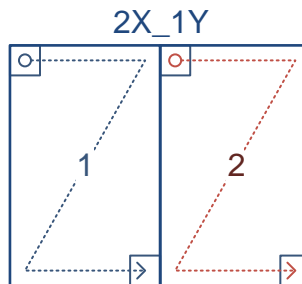

Figure 28-5: Geometry 2X-1Y (area-scan)

2X (line-scan)

2 zones in X.

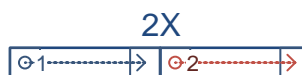

Figure 28-6: Geometry 2X (line-scan)

2XE-1Y (area-scan)

2 zones in X with end extraction, 1 zone in Y.

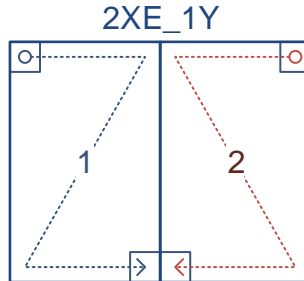

Figure 28-7: Geometry 2XE-1Y (area-scan)

2XE (line-scan)

2 zones in X with end extraction.



Figure 28-8: Geometry 2XE (line-scan)

2XM-1Y (area-scan)

2 zones in X with middle extraction, 1 zone in Y.

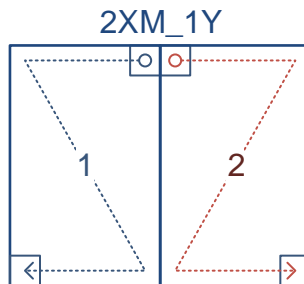

Figure 28-9: Geometry 2XM-1Y (area-scan)

2XM (line-scan)

2 zones in X with middle extraction.



Figure 28-10: Geometry 2XM (line-scan)

1X-1Y2 (*area-scan*)

1 zone in X, 1 zone in Y with 2 taps.

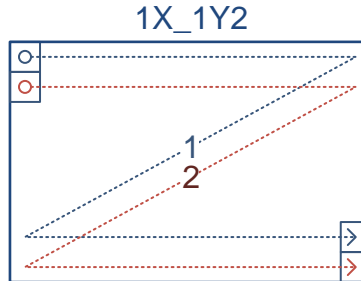

Figure 28-11: Geometry 1X-1Y2 (*area-scan*)

1X-2YE (*area-scan*)

1 zone in X, 2 zones in Y with end extraction.

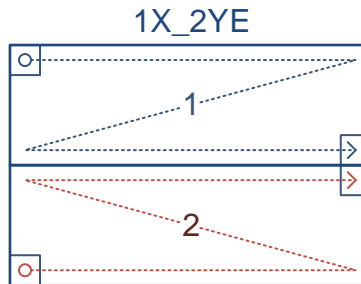

Figure 28-12: Geometry 1X-2YE (*area-scan*)

28.4 Triple Tap Geometries

1X3-1Y (area-scan)

1 zone in X with 3 taps, 1 zone in Y.

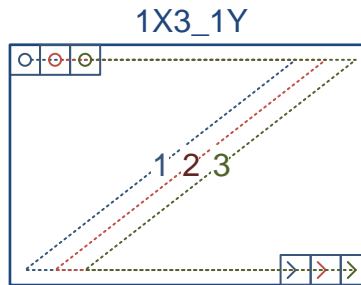

Figure 28-13: Geometry 1X3-1Y (area-scan)

1X3 (line-scan)

1 zone in X with 3 taps.



Figure 28-14: Geometry 1X3 (line-scan)

3X-1Y (area-scan)

3 zones in X, 1 zone in Y.

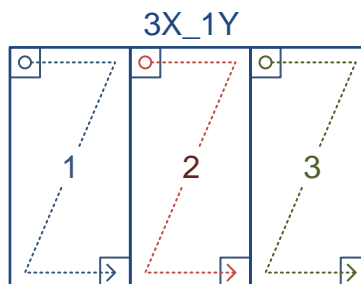

Figure 28-15: Geometry 3X-1Y (area-scan)

3X (line-scan)

3 zones in X.



Figure 28-16: Geometry 3X (line-scan)

28.5 Quad Tap Geometries

1X4-1Y (area-scan)

1 zone in X with 4 taps, 1 zone in Y.

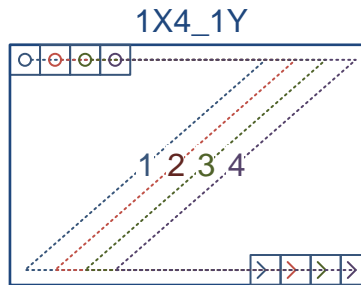

Figure 28-17: Geometry 1X4-1Y (area-scan)

1X4 (line-scan)

1 zone in X with 4 taps.



Figure 28-18: Geometry 1X4 (line-scan)

4X-1Y (area-scan)

4 zones in X, 1 zone in Y.

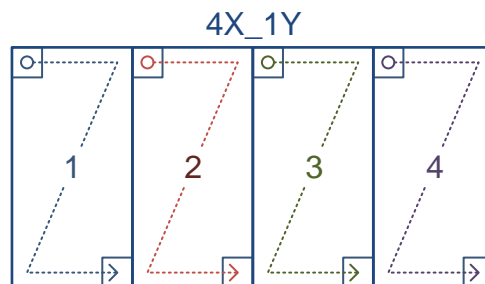

Figure 28-19: Geometry 4X-1Y (area-scan)

4X (line-scan)

4 zones in X.



Figure 28-20: Geometry 4X (line-scan)

2X2-1Y (area-scan)

2 zones in X with 2 taps, 1 zone in Y.

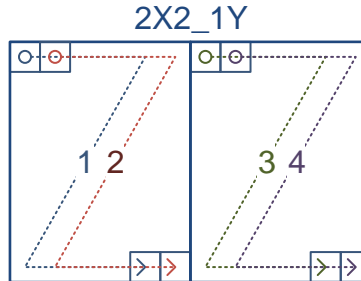

Figure 28-21: Geometry 2X2-1Y (area-scan)

2X2 (line-scan)

2 zones in X with 2 taps.



Figure 28-22: Geometry 2X2 (line-scan)

2X2E-1Y (area-scan)

2 zones in X with 2 taps and end extraction, 1 zone in Y.

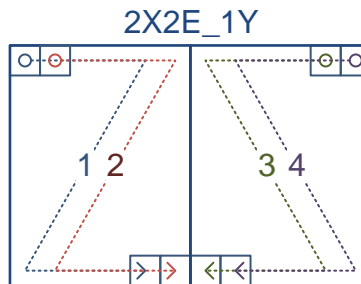

Figure 28-23: Geometry 2X2E-1Y (area-scan)

2X2E (line-scan)

2 zones in X with 2 taps and end extraction.



Figure 28-24: Geometry 2X2E (line-scan)

2X2M-1Y (area-scan)

2 zones in X with 2 taps and middle extraction, 1 zone in Y.

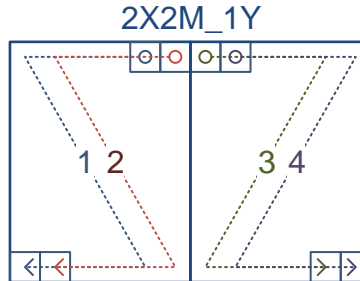

Figure 28-25: Geometry 2X2M-1Y (area-scan)

2X2M (line-scan)

2 zones in X with 2 taps and middle extraction.



Figure 28-26: Geometry 2X2M (line-scan)

1X2-2YE (area-scan)

1 zone in X with 2 taps, 2 zones in Y with end extraction.

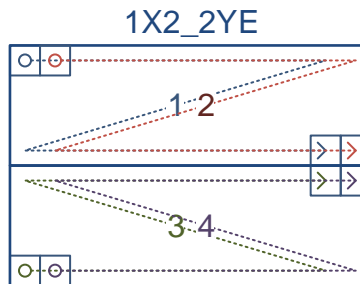

Figure 28-27: Geometry 1X2-2YE (area-scan)

2X-2YE (area-scan)

2 zones in X, 2 zones in Y with end extraction.

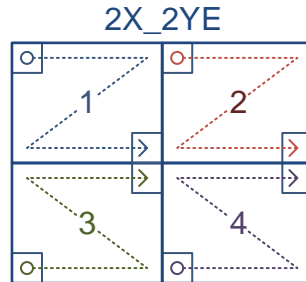

Figure 28-28: Geometry 2X-2YE (area-scan)

2XE-2YE (area-scan)

2 zones in X with end extraction, 2 zones in Y with end extraction.

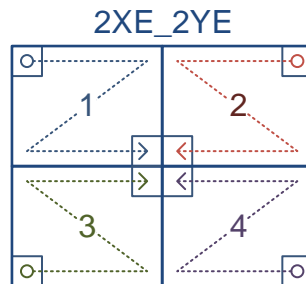

Figure 28-29: Geometry 2XE-2YE (area-scan)

2XM-2YE (area-scan)

2 zones in X with middle extraction, 2 zones in Y with end extraction.

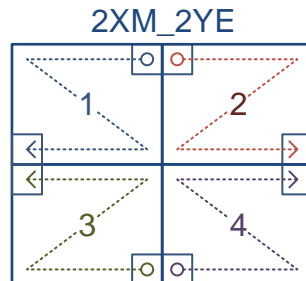

Figure 28-30: Geometry 2XM-2YE (area-scan)

28.6 Octal Tap Geometries

1X8-1Y (area-scan)

1 zone in X with 8 taps, 1 zone in Y.

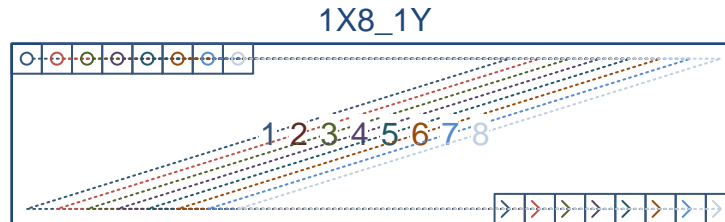

Figure 28-31: Geometry 1X8-1Y (area-scan)

1X8 (line-scan)

1 zone in X with 8 taps.



Figure 28-32: Geometry 1X8 (line-scan)

8X-1Y (area-scan)

8 zones in X, 1 zone in Y.

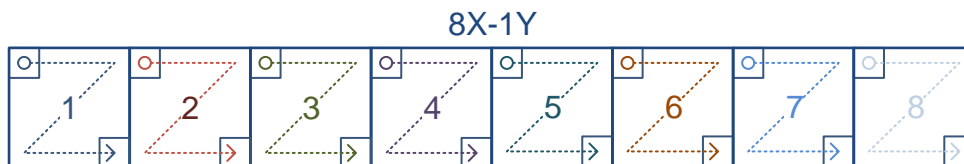

Figure 28-33: Geometry 8X-1Y (area-scan)

8X (line-scan)

8 zones in X.



Figure 28-34: Geometry 8X (line-scan)

4X2-1Y (area-scan)

4 zones in X with 2 taps, 1 zone in Y.

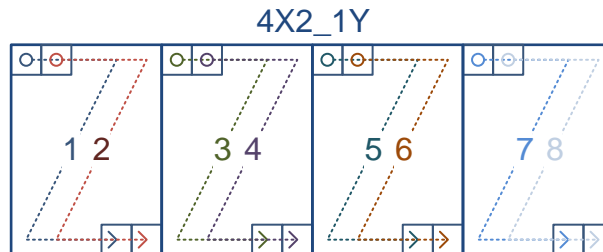

Figure 28-35: Geometry 4X2-1Y (area-scan)

4X2 (line-scan)

4 zones in X with 2 taps.

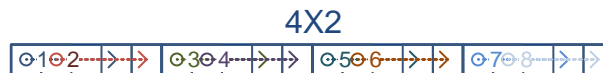

Figure 28-36: Geometry 4X2 (line-scan)

4X2E-1Y (area-scan)

4 zones in X with 2 taps and end extraction, 1 zone in Y.

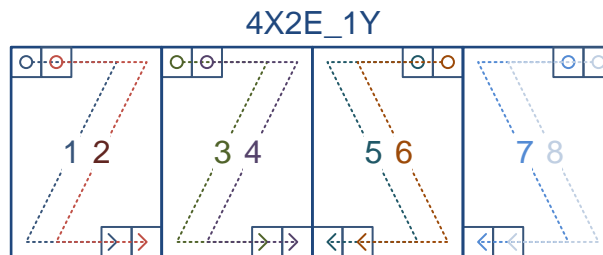

Figure 28-37: Geometry 4X2E-1Y (area-scan)

4X2E (line-scan)

4 zones in X with 2 taps and end extraction.



Figure 28-38: Geometry 4X2E (line-scan)

2X2E-2YE (area-scan)

2 zones in X with 2 taps, 2 zones in Y with 2 taps.

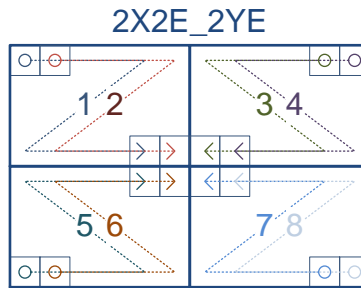

Figure 28-39: Geometry 2X2E-2YE (area-scan)

28.7 Deca Tap Geometries

1X10-1Y (area-scan)

1 zone in X with 10 taps, 1 zone in Y.

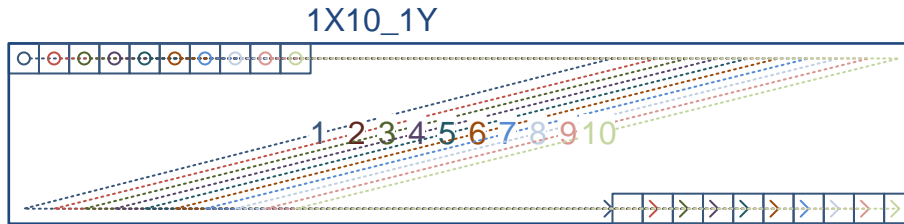

Figure 28-40: Geometry 1X10-1Y (area-scan)

1X10 (line-scan)

1 zone in X with 10 taps.



Figure 28-41: Geometry 1X10 (line-scan)

10X1Y (line-scan)

10 zone in X, 1 zone in Y with 10 taps.

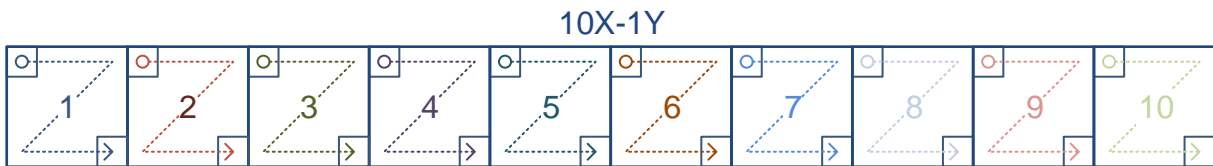

Figure 28-42: Geometry 10X-1Y (line-scan)

10X (*line-scan*)

10 zones in X.

10X



Figure 28-43: Geometry 10X (line-scan)