

GLOBAL MACHINE VISION **INTERFACE STANDARDS**

Understanding today's digital camera interface options

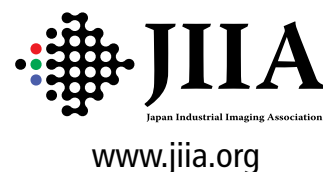



Member-supported trade associations promote the growth of the global vision and imaging industry. Standards development is key to the success of the industry and its trade groups help fund, maintain, manage and promote standards. In 2009, three leading vision associations, AIA, EMVA and JIIA began a cooperative initiative to coordinate the development of globally adopted vision standards. In 2015 they were joined by CMVU and VDMA-MV. This publication is one product of this cooperative effort.

Version: April 2016

Copyright 2013, AIA, EMVA and JIIA. All rights reserved.

Data within is intended as an information resource and no warranty for its use is given.

Camera Link (including PoCL and PoCL-Lite), Camera Link HS, GigE Vision and USB3 Vision are the trademarks of AIA. GenICam is the trademark of EMVA. CoaXPress and IIDC2 are the trademarks of JIIA. FireWire is the trademark of Apple Inc. IEEE 1394 is the trademark of The 1394 Trade Association. USB is the trademark of USB Implementers Forum, Inc. All other names are trademarks or trade names of their respective companies.

This is a comprehensive look at the various digital hardware and software interface standards used in machine vision and imaging.

In the early days of machine vision, the industry adopted existing analog television standards such as CCIR or RS-170 for the interface between cameras and frame grabbers.

In the 1990s, digital technology became prevalent and a multitude of proprietary interface solutions were used. This was a confusing environment for users of vision technology.

The development of FireWire/IEEE 1394 by Apple for the consumer market was a good first step, but the Camera Link standard, introduced in 2000, focused the technology and simplified the market. Camera Link still plays an important role in the industry, but new interfaces that address the growing spectrum of industries that use vision technology have been introduced. In 2006 GigE Vision was released, followed by CoaXPress, Camera Link HS and USB3 Vision on the hardware side.

On the software side, GenICam and IIDC2 were introduced to better support digital technology.



The defining characteristics of today's hardware and software standards outlined in this brochure provide a good foundation for understanding each interface option.

This is especially helpful to those unfamiliar with vision standards and to anyone migrating from analog to digital image acquisition technology.

INTRODUCTION TO DIGITAL STANDARD TECHNOLOGY

An interface standard codifies how a camera is connected to a PC, providing a defined model that allows simpler, more effective use of vision technology.

A vision system is comprised of various components, including cameras, frame grabbers and vision libraries; often from multiple manufacturers. Interface standards ensure that compliant components interoperate seamlessly.

Early analog standards provided a simple video transfer connection. Camera control and triggering was via a separate, vendor proprietary connection. Digital standards allow camera control and image transfer over a single wire. Digital image transfer features also provide greater flexibility and can simplify system design, reducing overall costs.

Vision applications require four basic tasks: finding and connecting to the camera; configuring the camera; grabbing images from the camera; and dealing with asynchronous events signaled by or to the camera.

Key Functions Provided by Digital Interface Standards



Two layers of software help with these tasks. The first layer is the transport layer (TL) which enumerates the camera, provides access to the camera's low-level registers, retrieves stream data from the device, and delivers events. The transport layer is governed by the hardware interface standard. Depending on the interface type, the transport layer requires a dedicated frame grabber (Camera Link, Camera Link HS, CoaXPress) or a bus adapter (FireWire, GigE Vision, USB3 Vision).

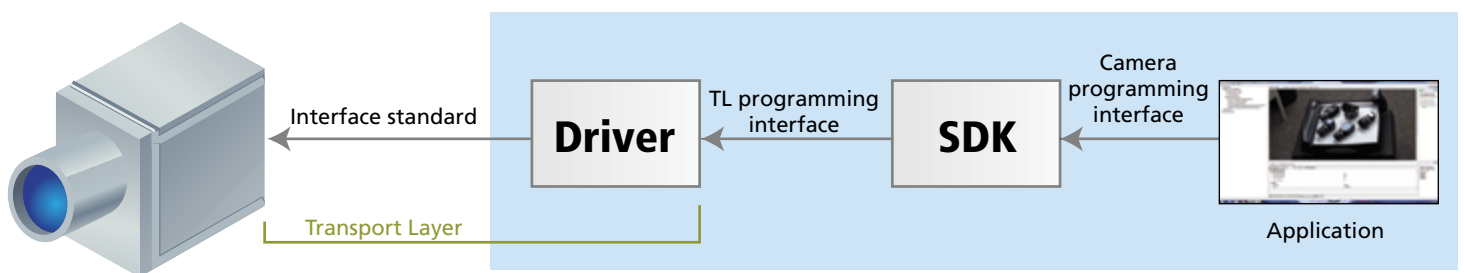

The second layer is the image acquisition library which is part of a software development kit (SDK). The SDK can be a stand-alone item, provided with a frame grabber, or in an image processing library. It uses the transport layer to access the camera functionality and allows grabbing images.

There are two principal standards for camera functionality and its mapping to registers: GenICam and IIDC2. Both are discussed in more detail in the software standards section of this brochure.



INTRODUCTION TO DIGITAL HARDWARE STANDARDS

The hardware components of a vision standard include cameras; computer connectors and cables; frame grabbers (if required); and all relevant specifications regarding configuration.

This section provides detailed descriptions of the latest hardware standards:

- Camera Link
- Camera Link HS
- CoaXPress
- GigE Vision
- USB3 Vision

In addition, two legacy general interface standards (FireWire and USB 2.0) are briefly discussed, however, their use in the machine vision industry is in decline as newer standards deliver greater performance advantages.

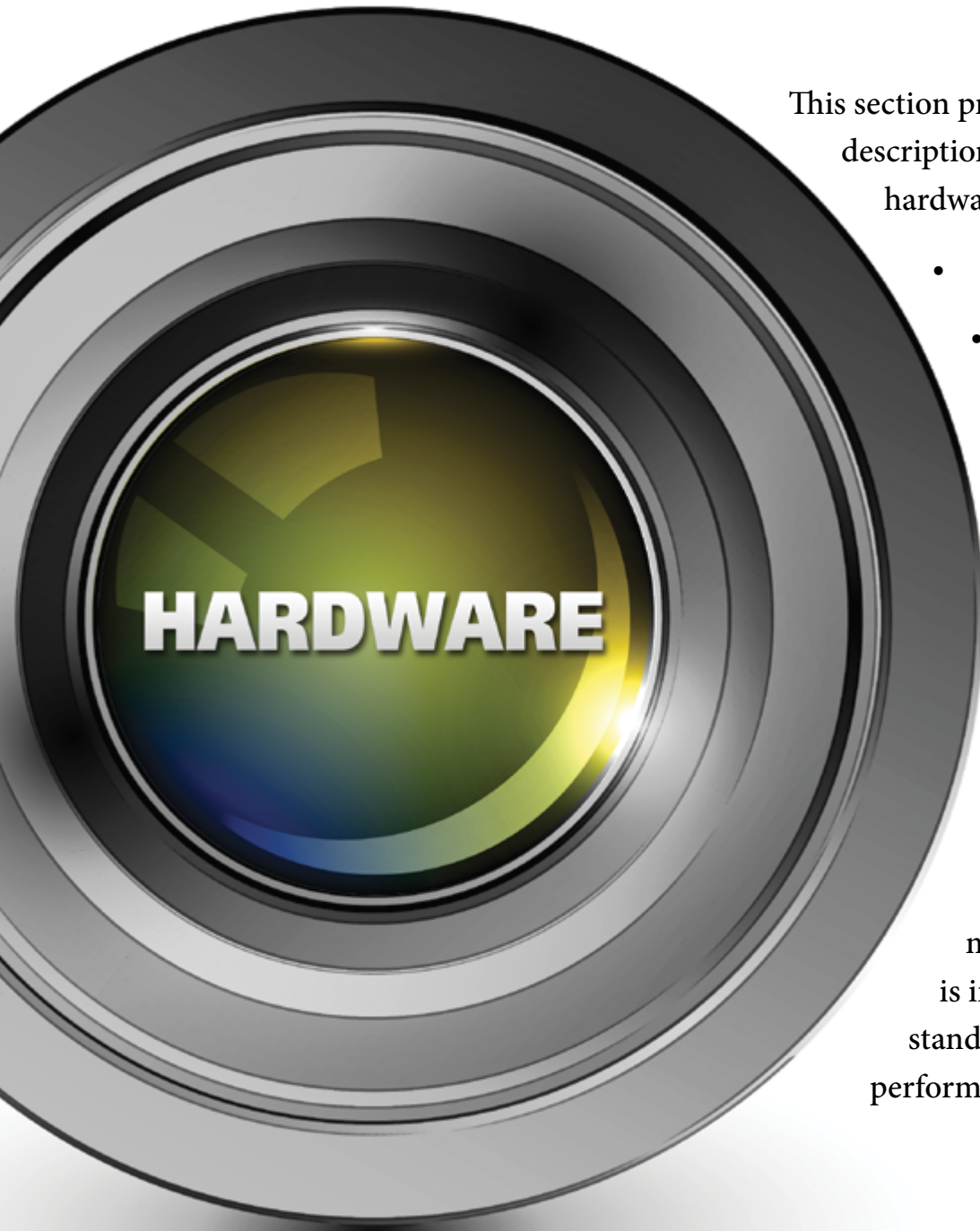



LEGACY GENERAL INTERFACE STANDARDS

IEEE1394

IEEE 1394, also known as FireWire, is an interface based on a technology developed by Apple Inc. in 1987. There are two types of IEEE 1394: IEEE 1394a and IEEE 1394b. For the machine vision market, IIDC is the FireWire data format protocol that defines the layout of the control registers inside the camera. The current version of IEEE 1394-IIDC (1.32) is multi-camera capable and offers connectivity of up to 63 devices per bus.

Speed

IEEE 1394a: 400 Mbits/s with 6 pin connector.

IEEE 1394b: in the IEEE 1394-2008 standard, up to 3.2G bits/s is defined, however today, 800 Mbits/s is common and 1.6 Gbits/s is sometimes seen with a 9 pin connector.

Receiver Device

PC (direct).

Cable

IEEE 1394 uses shielded twisted pair (STP) cable; with IEEE 1394b, an optical fiber cable (HPCF, GOF, POF) or UTP cable can be used.

Connectors

Latch type for IEEE 1394a; screw type for IEEE 1394b.

USB 2.0

USB 2.0 is one of the most popular commercial interface standards and can be found on virtually all PCs. Many cameras in machine vision applications are still equipped with USB 2.0 as the underlying transport layer. However, use of these cameras is in decline as they do not leverage any machine vision specific protocols and interoperability between vendors is problematic.



The Camera Link standard was initially released in 2000. It is a robust, well-established communications link that standardizes the connection between cameras and frame grabbers and defines a complete interface, including provisions for data transfer, camera timing, serial communications, and real-time signaling to the camera. Camera Link is a non packet-based protocol and remains the simplest camera/frame grabber interconnect standard. Currently in version 2.0, the standard specification includes Mini Camera Link connectors, Power over Camera Link (PoCL), PoCL-Lite (a minimized PoCL interface supporting base configurations) and cable performance specifications.

HDR 14-pin connector (PoCL-Lite)



SDR, HDR 26-pin connector (Mini Camera Link)



MDR 26-pin connector



Single Camera

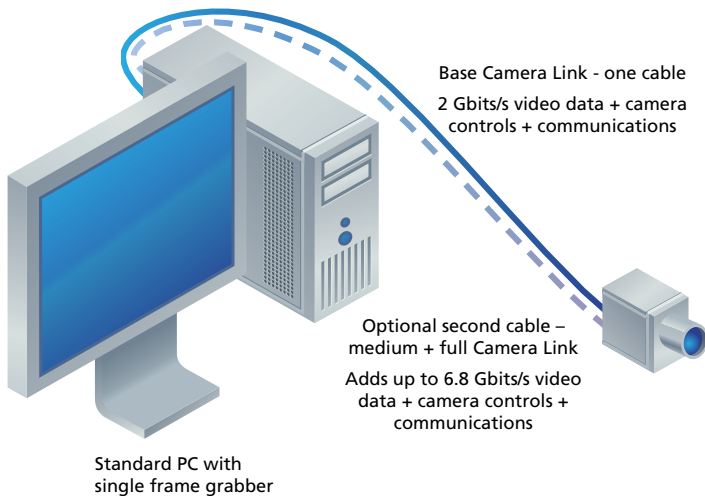

Speed

Camera Link was built for real-time, high speed communication. The high bandwidth of 255 Mbytes/s for one cable and up to 850 Mbytes/s for two cables assures fast transfer of images with no latency issues.

Receiver Device

Frame grabber.

Cable

Camera Link defines its own dedicated cable. Cameras and frame grabbers can be easily interchanged using the same cable. Maximum cable length is in the range of 7 to 15 meters depending on camera clock rate. Mini Camera Link provides a small footprint when space is an issue.

Double Base Configuration

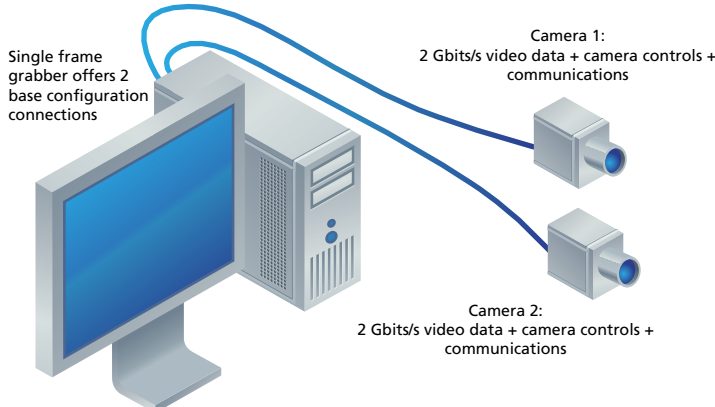

Connectors

MDR 26-pin connector; SDR, HDR 26-pin connector (Mini Camera Link); HDR 14-pin connector (PoCL-Lite).

Camera Power Supply

Using PoCL, a PoCL camera can be powered by a PoCL frame grabber through the Camera Link cable.

Other Differentiators

Camera Link has optional GenICam support for plug and play interoperability. Use of up to two cables per camera is possible.

		Standard name	Camera Link
		Initial release date	October 2000
		Current version	2.0 (February 2012)
Hosting association	AIA		
Standard website	www.visiononline.org/cameralink		
Related software standard	Mandatory	None	
	Optional	GenICam (CLProtocol)	
Output configurations	Configuration	Image data throughput	Number of cables
	Lite	100 Mbytes/s	1
	Base	255 Mbytes/s	1
	Medium	510 Mbytes/s	2
	Full	680 Mbytes/s	2
	80-bit	850 Mbytes/s	2
Image transfer robustness	Retransmission	None	
	Forward error correction	None	
Camera control	Uplink channel	Asynchronous serial comms	
	Downlink channel	Asynchronous serial comms	
	Trigger input signal	4 direct signal from frame grabber to camera	
Receiver devices	Frame grabber		
Supported transfer topologies	Point-to-point		
Cabling	Types	Max. length (typical at 85 MHz)	Power over cable (wattage at camera)
	Lite	10m	4W
	Base	10m	4W (optional)
	Medium	10m	8W (optional)
	Full	5m	8W (optional)
	80-bit	4m	8W (optional)
Other key characteristics	<ul style="list-style-type: none"> Well established, hundreds of camera models and frame grabbers currently available Three different connector sizes available Peer-to-peer direct signaling means limited latency for image data 		
Roadmap	Next version	2.1	
	Target release	Q2 2016	
	Key feature	HDR/SDR Standoff clarification	

CAMERA Link HS[®]

The Camera Link HS standard was released in May 2012, improving on Camera Link by using off-the-shelf cables to extend reach and also offering increased bandwidth. Camera Link HS features include: single bit error immune protocols; 16 bidirectional General Purpose Input Output (GPIO) signals; system level functions such as synchronizing multiple parallel processing frame grabber; and frame by frame control of camera operating mode from the host. Camera Link HS is supported at 3.125 Gbits/s per lane with the M protocol and at 10.3 Gbits/s per lane with the X protocol. Unencrypted VHDL Hardware Description Language (VHDL) IP cores are available, reducing interconnection issues and development risks when integrating Camera Link HS into original equipment manufacturer (OEM) or custom implementations. Even though Camera Link HS is a packet based protocol, it achieves trigger jitter of 6.4 nanoseconds (ns) using the IP core with typical latencies of 150 ns and GPIO latency and jitters in the 300 ns range.

SFP or SFP+ connector



SFF-8470 connector (InfiniBand or CX4)



Fiber optic cable



M Protocol, Multicamera using Copper Cable

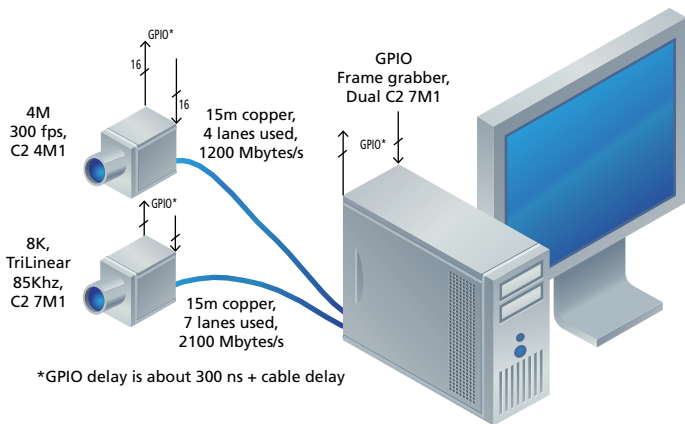

Speed

Camera Link HS is designed for parallel processing and supports 1 through 8 cables with per-cable effective bandwidths of 300 Mbytes/s (F1), 1200 Mbytes/s (F2) or 2100 Mbytes/s (C2 copper).

Receiver Device

Frame grabber.

Cable

C2 copper cable up to 15 meters; Fiber optic cable 500 meters; Direct attach up to 10 meters.

X Protocol, Fiber Optic using Parallel Image Processing

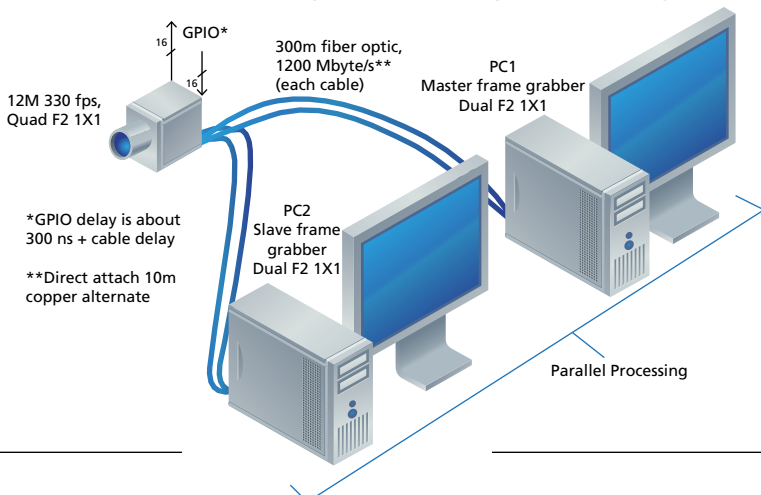

Connectors

Copper cable: SFF-8470 (InfiniBand or CX4);
Fiber optic cable: SFP or SFP+ connector.

Camera Power Supply

C2 cable compatible, but not planned.

Other Differentiators

Direct connection to FPGA serdes is possible.

		Standard name	Camera Link HS
		Initial release date	May 2012
		Current version	1.0 (May 2012)
Hosting association	AIA		
Standard website	www.visiononline.org/cameralinkhs		
Related software standard	Mandatory	GenICam (GenApi, SFNC, GenCP)	
	Optional	GenICam (GenTL)	
Output configurations <i>(selection only)</i>	Configuration	Image data throughput	Number of cables
	C2 - (CX4 cables)	2100 Mbytes/s	1
	Octal C2	16800 Mbytes/s	8
	F1- (SFP connector)	300 Mbytes/s	1
	Octal F1	2400 Mbytes/s	8
	F2- (SFP+ connector)	1200 Mbytes/s	1
	Octal F2	9600 Mbytes/s	8
Image transfer robustness	Retransmission	Performed by hardware layer with µsec latencies	
	Forward error correction	Performed by hardware layer	
Camera control	Uplink channel	Dedicated 300 (C2,F1) or 1200 (F2) Mbytes/s	
	Downlink channel	Shared with image data	
	Trigger input signal	Camera input pins, from frame grabber with optional frame by frame camera mode control	
Receiver devices	Frame grabber		
Supported transfer topologies	Point-to-point and/or data splitting	Data splitting synchronizes multiple FG cards in multiple PCs for parallel image processing	
Cabling	Types	Max. length	Power over cable (wattage at camera)
	C2 (Copper)	15m	No power
	F1/F2 Direct attach	10m	No power
	F1/F2 Multi-mode fiber	500m	No power
	F1/F2 Single-mode fiber	5000m	No power
Other key characteristics	<ul style="list-style-type: none"> IP core available from AIA ensuring interoperability and short development times Leverages components from high volume telecom industry Trigger message from camera to frame grabber is available 16 bi-directional GPIO with latencies under 500 ns 		
Roadmap	Next version	2.0	
	Target release	Q4 2016	
	Key features	<ul style="list-style-type: none"> M protocol speed increase X protocol QSFP connector Multiple Regions of Interest (ROI) support 	



The CoaXPRESS (CXP) standard was released in December 2010. It provides a high speed interface between cameras and frame grabbers and allows long cable lengths. In its simplest form, CoaXPRESS uses a single coaxial cable to: transmit data from a camera to a frame grabber at up to 6.25 Gbits/s; simultaneously transmit control data and triggers from the frame grabber to the camera at 20.8 Mbits/s; and provide up to 13W of power to the camera. Link aggregation is used when higher speeds are needed, with more than one coaxial cable sharing the data. Version 1.1 allows use of the smaller DIN 1.0/2.3 connector.

Multiway DIN connector



BNC connector



DIN 1.0/2.3 connector



Speed

CoaXPRESS supports real-time triggers, including triggering very high speed line scan cameras. With the standard 20.8 Mbits/s uplink to the camera, trigger latency is 3.4 microseconds (μ s), or with the optional high speed uplink, it is typically 150 ns. CoaXPRESS already supports the fastest cameras on the market with significant headroom by allowing up to 3.6 Gbytes/s with 6 links in one connector.

Receiver Device

Frame grabber.

Cable

At 1.25 Gbits/s link speed (CXP-1), CoaXPRESS supports cable lengths of over 100m; at 3.125 Gbits/s (CXP-3), the maximum length is 85m; and even at the maximum 6.25 Gbits/s (CXP-6), 35m cables with 6mm diameter can be used. Longer lengths are possible with larger diameter cables.

Connectors

The widely used BNC connector and smaller DIN 1.0/2.3. The DIN connector can also be combined into a multiway connector.

Camera Power Supply

Through CoaXPRESS cable.

Other Differentiators

Support for GenICam, including GenApi, SFNC, and GenTL (including image streaming) is mandatory. IIDC2 support is optional.

Single Camera

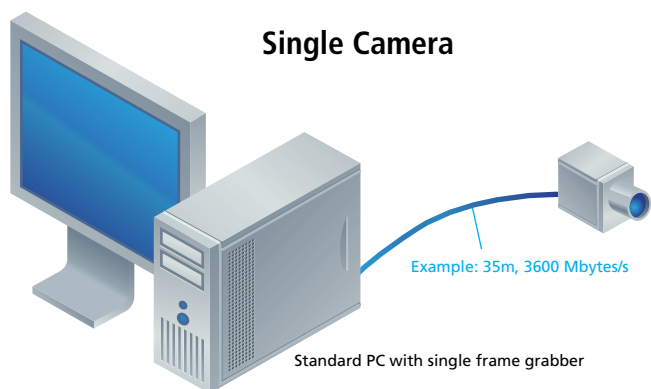

One cable provides image data, camera control and camera power.

Multiple Cameras, One Frame Grabber

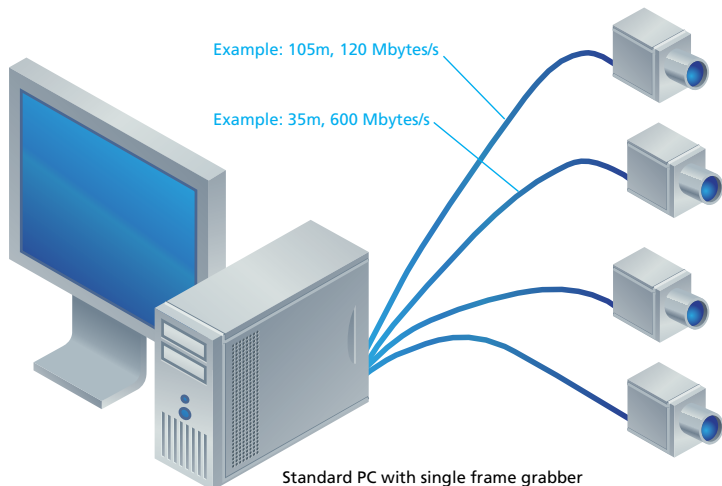

Standard PC with single frame grabber

		Standard name	CoaXPress
		Initial release date	December 2010
		Current version	1.1.1 (November 2015)
Hosting association	JIIA		
Standard website	www.coaxpress.com		
Related software standard	Mandatory	GenICam (GenApi, GenTL, SFNC)	
	Optional	IIDC2	
Output configurations <i>(selection only)</i>	Configuration	Image data throughput	Number of cables
	CXP-1	120 Mbytes/s	1 coax
	CXP-3	300 Mbytes/s	1 coax
	CXP-6	600 Mbytes/s	1 coax
	4x CXP-6	2400 Mbytes/s	4 coax, can be in 1 cable
	6x CXP-6	3600 Mbytes/s	6 coax, can be in 1 cable
Image transfer robustness	Error detection only	Achieved via CRC32	
Camera control	Uplink channel	Dedicated; 20.8 Mbits/s link is standard; optional up to 6.25 Gbits/s with additional coax	
	Downlink channel	Shared with image data	
	Trigger input signal	Protocol supports trigger from frame grabber; camera can also have trigger inputs	
Receiver devices	Frame grabber		
Supported transfer topologies	Point-to-point	Repeater device could allow forwarding to multiple receivers	
Cabling <i>(selection only)</i> <i>Note: Cable lengths shown are for 6mm diameter cable; longer lengths are possible with larger cables.</i>	Types	Max. length	Power over cable (wattage at camera)
	CXP-1	105m	13W
	CXP-3	85m	13W
	CXP-6	35m	13W
	4x CXP-6	35m	52W
	6x CXP-6	35m	78W
Other key characteristics	<ul style="list-style-type: none"> Single coaxial cable supports image data, control, triggering and power Trigger message from camera to frame grabber is available 		
Roadmap	Next version	2.0	
	Target release	Q3 2016	
	Key features	<ul style="list-style-type: none"> Increase in speed to support 10 and 12.5 Gbits/s Support for multiple frame grabbers/PCs for very high speed cameras Forward error correction Support for 3D data 	

GIG VISION[®]

The GigE Vision standard is a widely adopted camera interface standard developed using the Ethernet (IEEE 802.3) communication standard. Released in May 2006, the standard was revised in 2010 (version 1.2) and 2011 (version 2.0). GigE Vision supports multiple stream channels and allows for fast error-free image transfer over very long distances using standard Ethernet cables. Hardware and software from different vendors can interoperate seamlessly over Ethernet connections at various data rates. Other Ethernet standards, such as IEEE 1588, are leveraged to provide deterministic triggering.

Copper Ethernet cable

Copper Ethernet with vision locking screws

10 Gigabit Ethernet direct attach cable

Ethernet fiber optic cable

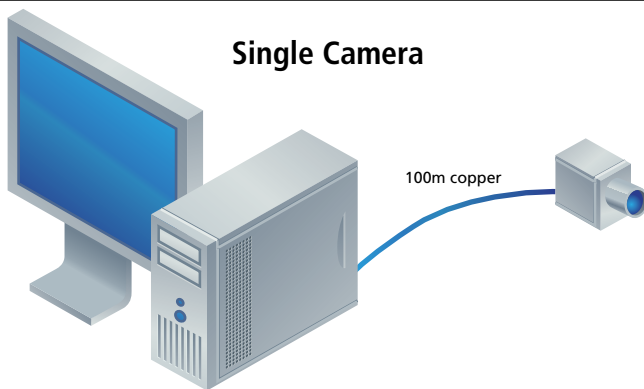
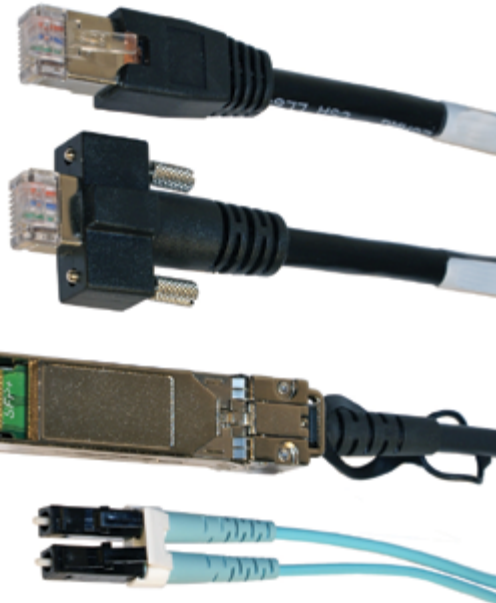

Single Camera

Line scan or area scan camera powered through Ethernet cable or externally.
Data rate up to 10 Gbits/s.
No frame grabber required.

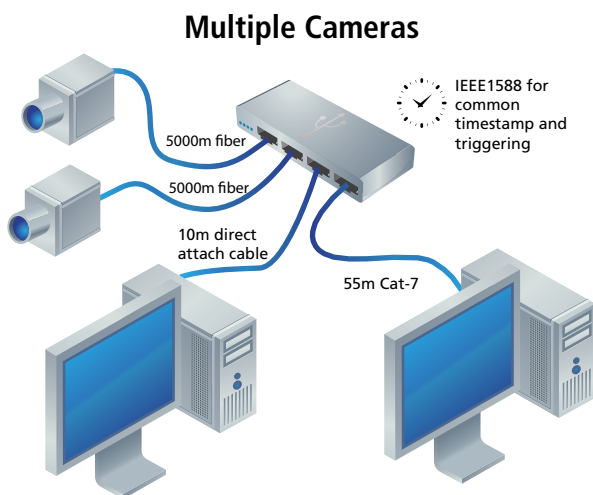

Multiple Cameras

Cameras powered through Ethernet cable or externally.
Total data rate up to 10 Gbits/s (for a 10 Gbits/s link to the PCs).

Speed

Currently 1 and 2 Gbits/s (using 2 cables) systems are readily available with a number of 10 Gbits/s and wireless systems introduced in 2014.

Receiver Device

PC (direct), with GigE interfaces built into almost all PCs and embedded systems, no additional interface card (frame grabber) is necessary in many situations.

Cable

Depending on the cable and number of cameras, GigE Vision allows cable lengths up to 100m (copper) and 5,000m (fiber optic) using a single camera.

Connectors

Connectors available for GigE Vision: Copper Ethernet; Copper Ethernet with vision locking screws; 10 Gigabit Ethernet direct attach cable; Ethernet fiber optic cable.

Camera Power Supply

Through Ethernet cable (POE) or externally.

Other Differentiators

As each GigE camera has its own IP-address, there is no limit to how many cameras can be operated on the same network.

		Standard name	GigE Vision	
		Initial release date	May 2006	
		Current version	2.0.03 (April 2013)	
Hosting association	AIA			
Standard website	www.visiononline.org/gigevision			
Related software standard	Mandatory	GenICam (GenApi, SFNC)		
	Optional	GenICam (GenTL)		
Output configurations	Configuration	Image data throughput	Number of cables	
	1 GigE	115 Mbytes/s	1 cable	
	2 x 1 GigE (link aggregation)	230 Mbytes/s	2 cables	
	10 GigE	1100 Mbytes/s	1 cable	
	WiFi	25 Mbytes/s	N/A	
Image transfer robustness	Retransmission	CRC, optional PacketResend command can be issued by receiver, image # tracking and packet # tracking.		
Camera control	Uplink channel	Symmetric with downlink channel		
	Downlink channel	Shared with image data		
	Trigger input signal	Hardware trigger on camera. Software trigger, optionally synchronized by Precision Time Protocol (IEEE1588)		
Receiver devices	Network interface card (NIC) can be on motherboard or inserted as an add-in card. Possibility to use a GigE Vision frame grabber.			
Supported transfer topologies	Point-to-point, multiple destinations	Direct connection to network card or to an Ethernet switch is possible. Support for multicast and broadcast.		
Cabling	Types	Max. length	Power over cable (wattage at camera)	
	CAT-5e/CAT-6a/CAT-7	100m	Optional 13W (IEEE802.3af) Optional 25W (IEEE802.3at)	
	2 x CAT-5e/CAT-6a/CAT-7 (link aggregation)	100m	Optional 26W (IEEE802.3af) Optional 50W (IEEE802.3at)	
	Multi-mode fiber	500m	No power	
	Single-mode fiber	5000m	No power	
	SFP+ direct attach	10m	No power	
Other key characteristics	<ul style="list-style-type: none"> ▪ Full networking capabilities, compatible with Ethernet switches ▪ GenICam metadata ▪ Event generation ▪ Multiple data format: uncompressed, JPEG, JPEG 2000, H.264 and others ▪ Action commands: trigger to multiple devices at the same time 			
Roadmap	Next version	2.1		
	Target release	Mid 2016		
	Key features	<ul style="list-style-type: none"> ▪ Mechanical specification ▪ Improved testability ▪ New pixel formats ▪ Support for 3D data 		

USB³ VISION

The USB3 Vision standard was initiated in late 2011, with version 1.0 published in January 2013. While the standard is new, the machine vision industry is not unfamiliar with USB technology. The USB interface brings broad levels of consumer awareness, easy plug and play installation, and high levels of performance. The expertise of many companies was combined to create a standard that accommodates the varied needs within the machine vision industry. This approach allows off-the-shelf USB host hardware and nearly any operating system to take advantage of hardware direct memory access (DMA) capabilities to directly transfer images from the camera into user buffers. Leveraging camera control concepts from the GenICam standard means end users can easily implement USB3 Vision into existing systems. With the USB-IF organization's established track record of continuously updating the USB standard to improve speed and add features (USB 3.1 has already been released which doubles the speed), USB3 Vision will continue to leverage these improvements.

Host side
(standard A
locking)



Device side
(micro-B locking)



Single Camera

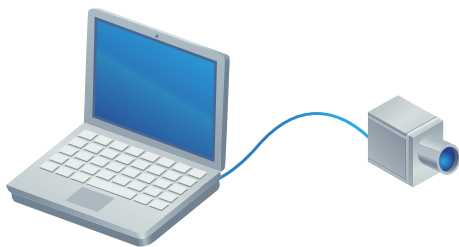

Camera connected by single cable to PC/laptop USB 3.0 ports providing power and up to 400 Mbytes/s data rate. No frame grabber required.

Speed

The standard builds upon the inherent aspects of USB 3.0, bringing end-to-end data reliability at over 400 Mbytes/s. The recently approved USB 3.1 standard more than doubles this effective speed but adoption has not yet started.

Receiver Device

PC (direct). With USB interfaces built into almost all PCs and embedded systems, no additional interface card (frame grabber) is necessary in many situations.

Multiple Cameras

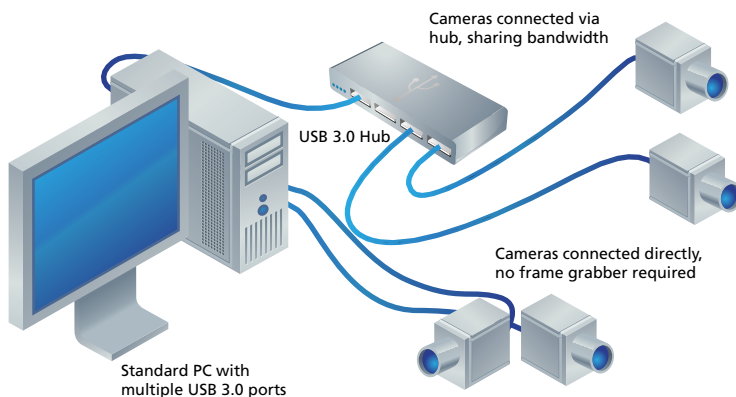

Cable

Standard passive copper cable 3-5m; active copper cable 8+m; multi-mode fiber optic cable 100m.

Connectors

USB3 Vision type connectors: host side (standard A locking) and device side (micro-B locking).

Camera Power Supply

Through standard passive copper cable 4.5W (5V, 950 mA) maximum; power supply through active copper varies, no power supply through multi-mode fiber optic.

Other Differentiators

Frame grabber like image transfer performance.

	Standard name	USB3 Vision	
	Initial release date	January 2013	
	Current version	1.0.1 (March 2015)	
Hosting association	AIA		
Standard website	www.visiononline.org/usb3vision		
Related software standard	Mandatory	GenICam (GenApi, SFNC, GenCP)	
	Optional	GenICam (GenTL), IIDC2	
Output configurations	Configuration	Image data throughput	Number of cables
	USB 3.0 SuperSpeed 5Gb	400 Mbytes/s	1 cable
Image transfer robustness	Automatic retransmit (USB bulk transfer)	Built into USB3 hardware implementation	
Camera control	Uplink channel	Symmetric with downlink channel	
	Downlink channel	Shared with image data	
	Trigger input signal	Hardware trigger on camera. Software trigger	
Receiver devices	Built-in interfaces, add-in cards		
Supported transfer topologies	Device to host	Star topology with switched data supported via hub. 127 devices maximum are connectable on one USB bus	
Cabling	Types	Max. length	Power over cable (wattage at camera)
	Standard Passive Copper	3-5m	4.5W
	Active Copper	8+m	Varies
	Multimode Fiber Optic	100m (typ)	No power
Other key characteristics	<ul style="list-style-type: none"> ▪ Machine vision type connector (screw-locking for USB3 on host and device side) ▪ Frame grabber like image transfer performance ▪ Plug and play detection ▪ Current version of the standard is already protocol and mechanically compatible with USB 3.1 standard bringing speeds to 800 Mbytes/s 		
Roadmap	Next version	1.1	
	Target release	Q1 2016	
	Key features	New: <ul style="list-style-type: none"> ▪ Multiple streams ▪ Support for 3D images 	

HARDWARE DIGITAL INTERFACE STANDARD COMPARISON

Name of Standard	IEEE1394 + IIDC		Camera Link			Camera Link HS		
Date of initial release	August 1996		October 2000			May 2012		
Current version	version 1.32		version 2.0			version 1.0		
Date of latest release	July 2008		February 2012			May 2012		
Topology	Daisy chain		Point-to-point			Point-to-point, data splitting		
Transmission format	Packet-based		Parallel			Packet-based		
Image transmission robustness	Error detection only		None			Data retransmission/ Forward error correction		
Related software standard	Mandatory: IIDC		Optional: GenICam CLProtocol			Mandatory: GenICam GenApi, GenCP, SFNC		
						Optional: GenICam GenTL		
Certification requirements	Self certification		Registration form, self certification			Registration form, compliance matrix		
Configuration	IEEE1394a (S400) IEEE1394b (S800)	IEEE1394b (S1600)	BASE	MEDIUM/ FULL	80-bit	C2	F2	8xF2 (splitting)
Bandwidth (image data)	★ ★★	★★	★★★★	★★★★★	★★★★★	★★★★★★	★★★★★★	★★★★★★
★: ≤ 100 Mbytes/s ★★: ≤ 200 Mbytes/s ★★★: ≤ 500 Mbytes/s ★★★★: ≤ 1000 Mbytes/s ★★★★★: > 1000 Mbytes/s								
Control channel	Full-duplex, shared with image data		Dedicated serial port			Dedicated uplink, shared downlink		
Cable types	IEEE 1394		Camera Link			CX4		Fiber
Cable length (passive cable)	★ ★★		★ ★★			★★ ★★★		★★★★★
★: ≤ 10 meters ★★: ≤ 20 meters ★★★: ≤ 50 meters ★★★★: ≤ 120 meters ★★★★★: > 120 meters								
Power over the cable	Mandatory		Optional			None		
Wattage available at camera	45W max (depends on PC)		4W	8W	8W	N/A		
Frame grabber required	No		Yes			Yes		
Camera trigger input signal	Direct on camera		On camera or from frame grabber			On camera or from frame grabber		
Trigger latency - frame grabber to camera (link latency, protocol overhead only)	N/A		★★★★★			★★★★		
★: ≥ 100 μs ★★: ≥ 10 μs ★★★: ≥ 1 μs ★★★★: ≥ 100 ns ★★★★★: < 100 ns								

CoaXPress			GigE Vision			USB3 Vision
December 2010			May 2006			January 2013
version 1.1.1			version 2.0.03			version 1.0.1
November 2015			April 2013			March 2015
Point-to-point			Point-to-point, network			Point-to-point, tiered-star
Packet-based			Packet-based			Packet-based
Error detection only			Data retransmission			Data retransmission
Mandatory: GenICam GenApi, GenTL, SFNC			Mandatory: GenICam GenApi, SFNC			Mandatory: GenICam GenApi, GenCP, SFNC
Optional: IIDC2			Optional: GenICam GenTL			Optional: GenICam GenTL, IIDC2
Registration form, electrical/protocol/ interoperability compliance tests, PlugFest			Registration form, compliance matrix, device validation software, PlugFest			Registration form, compliance matrix, device validation software, electrical compliance tests, PlugFest
CXP3	CXP6	4+1 CXP6 (LAG)	1 GigE	2x1GigE (LAG)	10 GigE	SuperSpeed 5 Gbits/s
★★★	★★★★	★★★★★	★★	★★★	★★★★	★★★
Dedicated uplink, shared downlink			Full-duplex, shared with image data			Full-duplex, shared with image data
Coaxial			CAT-5e/6a/7, Fiber		CAT-6a/7, Fiber	SuperSpeed USB
★★★★	★★★	★★★	★★★★ (CAT-5e/6a/7) ★★★★★ (Fiber)			★ (Copper) ★★★★ (Fiber Adapter)
Mandatory			Optional			Mandatory
13W		52W	13W (IEEE802.3af) 25W (IEEE802.3at)			4.5W
Yes			No			No
On camera or from frame grabber			Direct on camera			Direct on camera
★★★★			N/A			N/A

INTRODUCTION TO SOFTWARE STANDARDS FOR MACHINE VISION



Software standards are just as important as hardware standards to ensure machine vision system component interoperability.

The software side of an interface is composed of the transport layer (TL) and the libraries which come as part of a software development kit (SDK). The SDK can be either a stand-alone item, provided with a frame grabber, or provided as part of a third party vision library.

The transport layer can have a standardized or proprietary transport layer programming interface and deals only with shifting data between the camera and the host. It is the task of the SDK libraries to standardize functionality and to map to a camera's low level registers. The two principal methods used to accomplish this are GenICam and IIDC2.

The methods differ in that GenICam describes a list of features in the standard text, but the mapping to registers is implementation specific. The information on how to map camera functionality to camera registers is downloaded from the camera in a standardized format. The SDK libraries interpret that file and perform the mapping accordingly.

IIDC2 describes a fixed set of registers in the standard text, defining camera functionality and implementation details. For this type of standard, the SDK libraries normally contain a hard coded mapping of camera features to registers.

Hardware interface standards ensure that cameras can be connected to any driver or frame grabber. The software standards programming interface makes sure that the drivers can be used from different vision libraries or even directly by developers. Developers can exchange cameras, drivers or even the whole interface technology without having to make significant changes to software if they use a standards-based SDK.

GEN<i>CAM

GenICam (Generic Interface for Cameras) provides a generic programming interface for all kinds of cameras, no matter what hardware interface technology is used or what features are implemented. The objective of GenICam is to have the same application programming interface (API) used throughout the industry.

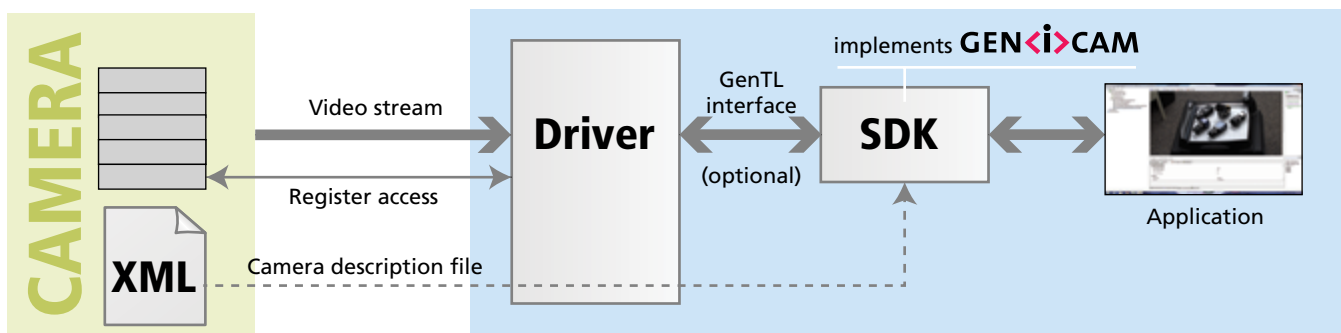

The GenICam standard is composed of several modules:

- **GenTL: (Generic Transport Layer)** standardizes the transport layer programming interface. This allows enumerating cameras, accessing camera registers, streaming data, and delivering asynchronous events. Since GenTL is a fairly low level interface, end users usually rely on an SDK instead of directly using GenTL. GenTL's main purpose is to ensure drivers and SDKs from different vendors work seamlessly together.
- **GenApi: (Generic Application Programming Interface)** standardizes the format of the camera self-description file. This file lists all of the features that are implemented by the camera (standard and custom) and defines their mapping to the camera's registers. The file format is based on XML and thus readable by humans. Typically, this file is stored in the camera firmware and is retrieved by the SDK when the camera is first connected to a system.
- **SFNC: (Standard Feature Naming Convention)** standardizes the name, type, meaning and use of camera features in the camera self-description file. This ensures that cameras from different vendors always use the same names for the same provided functionality.
- **GenCP: (Generic Control Protocol)** standardizes packet layout for the control protocol and is used by interface standards to re-use parts of the control path implementation.

Members of the GenICam standard group maintain a reference implementation that parses the file containing the self-description of the camera. The production quality code is written in C++, and can be used free of charge. It is highly portable and available on a range of operating systems and compilers. Most available SDK implementations use this reference implementation as the engine under the hood, thus ensuring a high degree of interoperability.



The IIDC2 standard, which is a successor to IIDC for FireWire cameras, defines a flexible-fixed camera control register layout. All details are defined for how each feature, such as exposure time, is mapped to the register space, representing a very simple approach to camera control.

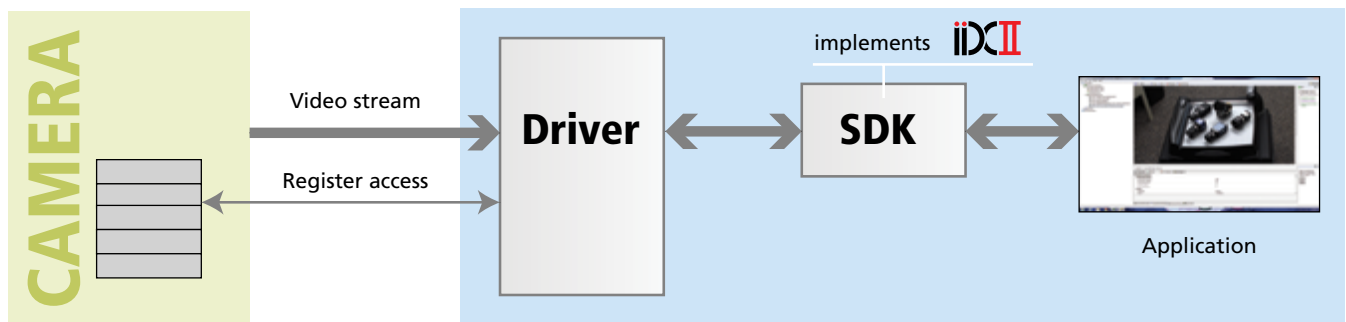

IIDC2 aims to be:

- Easy to implement and use
- Accessible to camera control registers
- Expandable for vendor specific functions
- A common controlling method for all cameras
- Usable on IEEE1394, but also on USB3 Vision, CoaXPress and future interfaces
- Able to be mapped to a GenICam interface

The standard offers an easy method for controlling cameras by only reading/writing registers directly inside the camera. All information regarding camera functionality is in the camera control registers. Users can determine supported features by reading the registers.

The register mapping works as a semi-fixed method, meaning a fixed mapping of accessibility and a free mapping for expandability. The camera functions are categorized into basic functions (fixed register layout and its behavior) and expanded functions. Functions can be added freely by the vendor, its register layout is selectable from the list in the specification and its behavior is vendor-specific. When using IIDC2 registers with GenICam, the camera description file can be common for all cameras because the IIDC2 register layout is defined in the specification.

DIGITAL SOFTWARE STANDARD COMPARISON TABLE

	GenICam	IIDC2
Basics		
Initial release date	September 2006	January 2012
Current version	3.0 (December 2015)	1.1.0 (June 2015)
Hosting association	EMVA	JIIA
Standard website	www.genicam.org	www.jiia.org
Transport Layer Programming Interface	supported (GenTL module)	not supported
Enumerating cameras	yes	-
Accessing camera registers	yes	-
Streaming video data, including 3D data		-
Delivering asynchronous events	yes	-
Supported by hardware standards		
mandatory	CXP	-
optional	1394, CL, CLHS, GEV, U3V	-
Camera Programming Interface	supported (GenApi + SFNC module)	supported
Method of operation	camera description file	hard-coded register set
Number of defined standard features	500+	73
Custom feature support	yes	yes
Event delivery	yes	-
Chunk data access	yes	-
Supported by hardware standards		
mandatory	CXP, CLHS, GEV, U3V	-
optional	1394, CL	1394, CXP, U3V
Reference Implementation	available (GenApi module)	not required
Free of charge	yes	-
Production quality	yes	-
Programming language	C++	-
Supported operating systems	Windows (32/64), Linux (32/64/ARM), Mac OS X	-
Supported compilers	Visual Studio, GCC	-
Roadmap		
Next version	3.1	1.2.0
Target release	TBD	Q2 2017
Key features	TBD	Improved: image format, trigger control, peripheral support

