

| | | |
|---|----------------|--|
| GEN<math>i</math>CAM | |  emva |
| Version 1.4 | GenTL Standard | |

GenICam GenTL Standard

Version 1.4

GENiCAM

Contents

| | | |
|-------|--|----|
| 1 | Introduction | 11 |
| 1.1 | Purpose | 11 |
| 1.2 | GenTL Subcommittee | 11 |
| 1.3 | Acronyms and Definitions | 11 |
| 1.3.1 | Acronyms | 11 |
| 1.3.2 | Definitions | 12 |
| 1.4 | References | 12 |
| 2 | Architecture | 13 |
| 2.1 | Overview | 13 |
| 2.1.1 | GenICam GenTL | 13 |
| 2.1.2 | GenICam GenApi | 13 |
| 2.1.3 | GenICam GenTL SFNC | 14 |
| 2.2 | GenTL Modules | 14 |
| 2.2.1 | System Module | 15 |
| 2.2.2 | Interface Module | 15 |
| 2.2.3 | Device Module | 16 |
| 2.2.4 | Data Stream Module | 16 |
| 2.2.5 | Buffer Module | 16 |
| 2.3 | GenTL Module Common Parts | 16 |
| 2.3.1 | C Interface | 17 |
| 2.3.2 | Configuration | 18 |
| 2.3.3 | Signaling (Events) | 18 |
| 3 | Module Enumeration and Instantiation | 19 |
| 3.1 | Setup | 19 |
| 3.2 | System | 20 |
| 3.3 | Interface | 21 |
| 3.4 | Device | 23 |
| 3.5 | Data Stream | 24 |
| 3.6 | Buffer | 24 |
| 3.7 | Enumerated modules list overview | 25 |

| | | |
|--------|-----------------------------------|----|
| 3.8 | Example..... | 26 |
| 3.8.1 | Basic Device Access | 26 |
| 3.8.2 | InitLib..... | 27 |
| 3.8.3 | OpenTL | 27 |
| 3.8.4 | OpenFirstInterface..... | 27 |
| 3.8.5 | OpenFirstDevice..... | 27 |
| 3.8.6 | OpenFirstDataStream | 28 |
| 3.8.7 | CloseDataStream | 28 |
| 3.8.8 | CloseDevice | 28 |
| 3.8.9 | CloseInterface..... | 29 |
| 3.8.10 | CloseTL..... | 29 |
| 3.8.11 | CloseLib | 29 |
| 4 | Configuration and Signaling | 30 |
| 4.1 | Configuration | 30 |
| 4.1.1 | Modules..... | 30 |
| 4.1.2 | XML Description | 31 |
| 4.1.3 | Example..... | 33 |
| 4.2 | Signaling..... | 34 |
| 4.2.1 | Event Objects | 34 |
| 4.2.2 | Event Data Queue..... | 37 |
| 4.2.3 | Event Handling..... | 37 |
| 4.2.4 | Example..... | 40 |
| 4.3 | Data Payload Delivery | 40 |
| 5 | Acquisition Engine..... | 42 |
| 5.1 | Overview | 42 |
| 5.1.1 | Announced Buffer Pool..... | 42 |
| 5.1.2 | Input Buffer Pool..... | 42 |
| 5.1.3 | Output Buffer Queue | 42 |
| 5.2 | Acquisition Chain..... | 43 |
| 5.2.1 | Allocate Memory..... | 44 |
| 5.2.2 | Announce Buffers | 45 |
| 5.2.3 | Queue Buffers | 46 |

| | | |
|--------|---------------------------------------|-----|
| 5.2.4 | Register New Buffer Event | 46 |
| 5.2.5 | Start Acquisition..... | 46 |
| 5.2.6 | Acquire Image Data | 46 |
| 5.2.7 | Stop Acquisition..... | 47 |
| 5.2.8 | Flush Buffer Pools and Queues | 47 |
| 5.2.9 | Revoke Buffers..... | 47 |
| 5.2.10 | Free Memory | 48 |
| 5.3 | Buffer Handling Modes..... | 48 |
| 5.3.1 | Default Mode..... | 48 |
| 5.4 | Chunk Data Handling | 49 |
| 5.4.1 | Overview | 49 |
| 5.4.2 | Example..... | 50 |
| 6 | Software Interface | 52 |
| 6.1 | Overview | 52 |
| 6.1.1 | Installation..... | 52 |
| 6.1.2 | Function Naming Convention | 52 |
| 6.1.3 | Memory and Object Management..... | 53 |
| 6.1.4 | Thread and Multiprocess Safety..... | 53 |
| 6.1.5 | Error Handling..... | 54 |
| 6.1.6 | Software Interface Versions | 56 |
| 6.2 | Used Data Types | 57 |
| 6.3 | Function Declarations | 58 |
| 6.3.1 | Library Functions | 58 |
| 6.3.2 | System Functions | 61 |
| 6.3.3 | Interface Functions..... | 68 |
| 6.3.4 | Device Functions..... | 75 |
| 6.3.5 | Data Stream Functions | 81 |
| 6.3.6 | Port Functions | 92 |
| 6.3.7 | Signaling Functions..... | 101 |
| 6.4 | Enumerations..... | 107 |
| 6.4.1 | Library and System Enumerations | 107 |
| 6.4.2 | Interface Enumerations | 110 |

| | | |
|-------|---|-----|
| 6.4.3 | Device Enumerations | 111 |
| 6.4.4 | Data Stream Enumerations | 114 |
| 6.4.5 | Port Enumerations | 128 |
| 6.4.6 | Signaling Enumerations | 131 |
| 6.5 | Structures..... | 135 |
| 6.5.1 | Signaling Structures | 135 |
| 6.5.2 | Port Structures | 135 |
| 6.5.3 | Generic Chunk Parser Structures | 136 |
| 6.6 | String Constants | 136 |
| 6.6.1 | Transport Layer Types | 136 |
| 6.7 | Numeric Constants | 137 |
| 7 | Standard Feature Naming Convention for GenTL..... | 138 |
| 7.1 | Common..... | 138 |
| 7.1.1 | System Module..... | 138 |
| 7.1.2 | Interface Module | 139 |
| 7.1.3 | Device Module | 141 |
| 7.1.4 | Data Stream Module..... | 141 |
| 7.1.5 | Buffer Module | 142 |

Figures

| | |
|--|----|
| Figure 2-1: GenTL Consumer and GenTL Producer | 13 |
| Figure 2-2: GenTL Module hierarchy | 15 |
| Figure 2-3: GenICam GenTL interface (C and GenApi Feature-interface)..... | 17 |
| Figure 3-4: Enumeration hierarchy of a GenTL Producer | 19 |
| Figure 5-5: Acquisition chain seen from a buffer's perspective (default buffer handling mode) | 44 |
| Figure 5-6: Default acquisition from the GenTL Consumer's perspective..... | 49 |

Tables

| | |
|---|-----|
| Table 4-1: Local URL definition for XML description files in the module register map..... | 32 |
| Table 4-2: Event types per module | 35 |
| Table 6-3: Function naming convention | 52 |
| Table 6-4: C interface error codes | 54 |
| Table 7-5: System module information features | 138 |
| Table 7-6: Interface enumeration features | 139 |
| Table 7-7: Interface information features..... | 140 |
| Table 7-8: Device enumeration features | 140 |
| Table 7-9: Device information features | 141 |
| Table 7-10: Stream enumeration features | 141 |
| Table 7-11: Data Stream information features | 141 |
| Table 7-12: Buffer information features | 142 |

Changes

| Version | Date | Author | Description |
|---------|----------------------------|--|--|
| 0.1 | May 1 st 2007 | Rupert Stelz, STEMMER IMAGING | 1 st Version |
| 0.2 | July 18 th 2007 | Rupert Stelz, STEMMER IMAGING | Added Enums Added Std Features Added AcqMode Drawings |
| 0.3 | November 2007 | GenTL Subcommittee: Rupert Stelz, STEMMER IMAGING Sascha Dorenbeck, STEMMER IMAGING Jan Becvar, Leutron Vision Carsten Bienek, IDS Francois Gobeil, Pleora Technologies Christoph Zierl, MVTec | Applied changes as discussed on the last meeting in Ottawa |
| 0.4 | Januar 2008 | GenTL Subcommittee | Removed EventGetDataEx and CustomEvent functionality Added comments from IDS, Matrix Vision, Matrox, Pleora, Leutron Vision, STEMMER IMAGING |
| 1.0 | August 2008 | Standard Document Release | |
| 1.1 | September 2009 | GenTL Subcommittee | Changes for V. 1.1: <ul style="list-style-type: none"> • Support of multiple XML-files (Manifest) • Added stacked register access • Changes for using the new endianness scheme • Changes to the installation procedure / location • Added new error codes • Definition of the symbol exports under 64Bit OS • Clarifications to the text |
| 1.2 | April 2010 | GenTL Subcommittee | Changes for V. 1.2 <ul style="list-style-type: none"> • Various clarifications, in particular event objects, feature change handling, event buffer handling • Extension to the BUFFER_INFO_CMD • New error code GC_ERR_NOT_AVAILABLE • Added data payload delivery chapter • Added payload datatype |
| 1.3 | August 2011 | GenTL Subcommittee | Changes for V. 1.3 <ul style="list-style-type: none"> • Renamed “Acquisition Mode” to “Buffer Handling Mode” • Various clarifications, in particular buffer |

| | | | |
|-----|------------|--------------------|---|
| | | | <p>alignment, error codes, thread safety, multiprocess access, default buffer handling mode</p> <ul style="list-style-type: none"> • Added Chunk Data handling in text and function interface • Adjusted Data Stream features to SFNC • Added “Software Interface Version” chapter • Added ptrdiff_t type • New error code GC_ERR_INVALID_ADDRESS • Deprecation of StreamAcquisitionModeSelector, introducing StreamBufferHandlingMode instead. • Clarified buffer alignment |
| 1.4 | March 2013 | GenTL Subcommittee | <p>Changes for V. 1.4</p> <ul style="list-style-type: none"> • New PAYLOADTYPE_IDs including the ones necessary to reflect GEV2.0 types. Adjust Chunk-Payloadtypes. • Typos • Clarifications • Remove technology specific names from chapter 7 and refer to GenTL SFNC • Renamed of TLTYPE USB3 to U3V • Added functions to retrieve the parent modules • Added Device info commands • Added Port info command • Added Pixel Endianness • Added numeric constants for infinite timeouts and invalid handles. • Added clarification that Schema Version as part of the URL is only to be used with legacy GCGetPortURL function • Added BUFFER_INFO_DATA_SIZE and explanation. • Added ZIP clarification • Added BUFFER_INFO_TIMESTAMP_NS and DEVICE_INFO_TIMESTAMP_FREQUENCY • Changed ‘revision’ to ‘version’ • Clarification of STREAM_INFO_NUM_DELIVERED • Added reference to SFNC Transfer Control features. • Clarification on Module enumeration issues • Added reference to GenTL SFNC • Added PFNC to PixelFormatNamespaces • Extended return code information for GenTL functions |

| | | | |
|--|--|--|--|
| | | | <ul style="list-style-type: none"> • Added UTF8 encoding • Added return code descriptions • Rename of EVENT FEATURE DEVEVENT to EVENT REMOTE DEVICE • Added EVENT MODULE • Added GC ERR INVALID VALUE • Deprecated PAYLOAD TYPE EXTENDED CHUNK and changed comment on PAYLOAD TYPE CHUNK DATA • Added GC ERR RESOURCE EXHAUSTED and GC ERR OUT OF MEMORY • Added error codes to function descriptions. • Clarify number of images to acquire in DSStartAcquisition • Added clarification to EventKill function • Clarified handling of too small buffers • Clarified the retrieval of the payload size from the GenTL Producer • Clarified the behavior of EventKill/EventGetData |
|--|--|--|--|

1 Introduction

1.1 Purpose

The goal of the GenICam GenTL standard is to provide a generic way to enumerate devices known to a system, communicate with one or more devices and, if possible, stream data from the device to the host independent from the underlying transport technology. This allows a third party software to use different technologies to control cameras and to acquire data in a transport layer agnostic way.

The core of the GenICam GenTL standard is the definition of a generic Transport Layer Interface (TLI). This software interface between the transport technology and a third party software is defined by a C interface together with a defined behavior and a set of standardized feature names and their meaning. To access these features the GenICam GenApi module is used.

The GenICam GenApi module defines an XML description file format to describe how to access and control device features. The Standard Feature Naming Convention defines the behavior of these features.

The GenTL software interface does not cover any device-specific functionality of the remote device except the one to establish communication. The GenTL provides a port to allow access to the remote device features via the GenApi module.

This makes the GenTL the generic software interface to communicate with devices and stream data from them. The combination of GenApi and GenTL provides a complete software architecture to access devices, for example cameras.

1.2 GenTL Subcommittee

The GenTL Subcommittee is part of the GenICam Group hosted by the EMVA.

1.3 Acronyms and Definitions

1.3.1 Acronyms

| Term | Description |
|------------|--|
| CL | Camera Link |
| CTI | Common Transport Interface |
| GenApi | GenICam Module |
| GenICam | Generic Interface to Cameras |
| GenTL | Generic Transport Layer |
| GenTL SFNC | GenICam Module: GenTL Standard Feature Naming Convention |

| | | |
|-----------------------|----------------|---|
| GEN<i>i</i>CAM | |  |
| Version 1.4 | GenTL Standard | |

| Term | Description |
|------|--|
| GigE | Gigabit Ethernet |
| IIDC | 1394 Trade Association Instrumentation and Industrial Control Working Group, Digital Camera Sub Working Group. |
| PC | Personal Computer |
| SFNC | GenICam Module: Standard Feature Naming Convention |
| TLI | Generic Transport Layer Interface |
| USB | Universal Serial Bus |
| UVC | USB Video Class |

1.3.2 Definitions

| Term | Description |
|----------------|--|
| Configuration | Configuration of a module through the GenTL Port functions, a GenApi compliant XML description and the GenTL Standard Feature Naming Convention. |
| GenApi | GenICam module defining the XML Schema which is used to describe register maps. |
| GenTL | Generic Transport Layer Interface |
| GenTL Consumer | A library or application using an implementation of a Transport Layer Interface |
| GenTL Producer | Transport Layer Interface implementation |
| Signaling | Mechanism to notify the calling GenTL Consumer of an asynchronous event. |
| TLParamsLocked | XML-Feature in the XML of the remote device to prevent the change of certain features during an acquisition. |

1.4 References

- AIA GigE Vision Standard <http://www.machinevisiononline.org/>
- EMVA GenICam Standard www.genicam.org
- ISO C Standard (ISO/IEC 9899:1990(E))
- RFC 3986 Uniform Resource Identifier
- RFC 1951 DEFLATE Compressed Data Format Specification v1.3

2 Architecture

This section provides a high level view of the different components of the GenICam GenTL standard.

2.1 Overview

The goal of GenTL is to provide an agnostic transport layer interface to acquire images or other data and to communicate with a device. It is not its purpose to configure the device except for the transport related features – even if it must be indirectly used in order to communicate configuration information to and from the device.

2.1.1 GenICam GenTL

The standard text’s primary concern is the definition of the GenTL Interface and its behavior. However, it is also important to understand the role of the GenTL in the whole GenICam system.

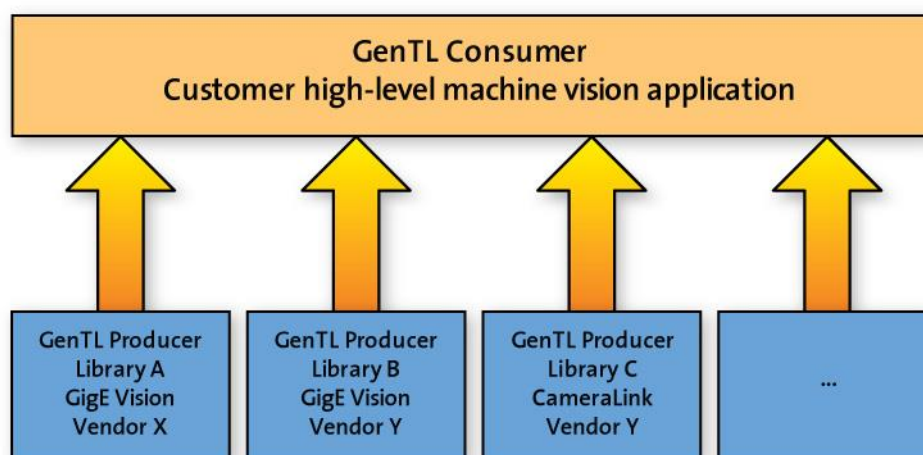

Figure 2-1: GenTL Consumer and GenTL Producer

When used alone, GenTL is used to identify two different entities: the GenTL Producer and the GenTL Consumer.

A GenTL Producer is a software driver implementing the GenTL Interface to enable an application or a software library to access and configure hardware in a generic way and to stream image data from a device.

A GenTL Consumer is any software which can use one or multiple GenTL Producers via the defined GenTL Interface. This can be for example an application or a software library.

2.1.2 GenICam GenApi

It is strongly recommended not to use the GenApi module inside the GenTL Producer implementations. If it is used internally no access to it may be given through the C interface. Some reasons are:

| | | |
|-------------------------------|----------------|---|
| GEN<i><i></i>CAM | |  |
| Version 1.4 | GenTL Standard | |

- **Retrieval of the correct GenICam XML file:** for the device configuration XML there is no unique way a GenTL Producer can create a node map that will be always identical to the one used by the application. Even if in most cases the XML is retrieved from the device, it cannot be assumed that it will always be the case.
- **GenICam XML description implementation:** there is no standardized implementation. GenApi is only a reference implementation, not a mandatory standard. User implementations in the same or in a different language may be used to interpret GenApi XML files. Even if the same implementation is used, the GenTL Producer and Consumer may not even use the same version of the implementation.
- **Caching:** when using another instance of an XML description inside the GenTL Producer, unwanted cache behavior may occur because both instances will be maintaining their own local, disconnected caches.

2.1.3 GenICam GenTL SFNC

In order to allow configuration of a GenTL Producer each module implements a virtual register map and provides a GenApi compliant XML file (see chapter 2.3.2). Only mandatory features of these XML files are described in this document in chapter 7. All features (mandatory and non mandatory) are defined in the GenTL SFNC document.

2.2 GenTL Modules

The GenTL standard defines a layered structure for libraries implementing the GenTL Interface. Each layer is defined in a module. The modules are presented in a tree structure with the System module as its root.

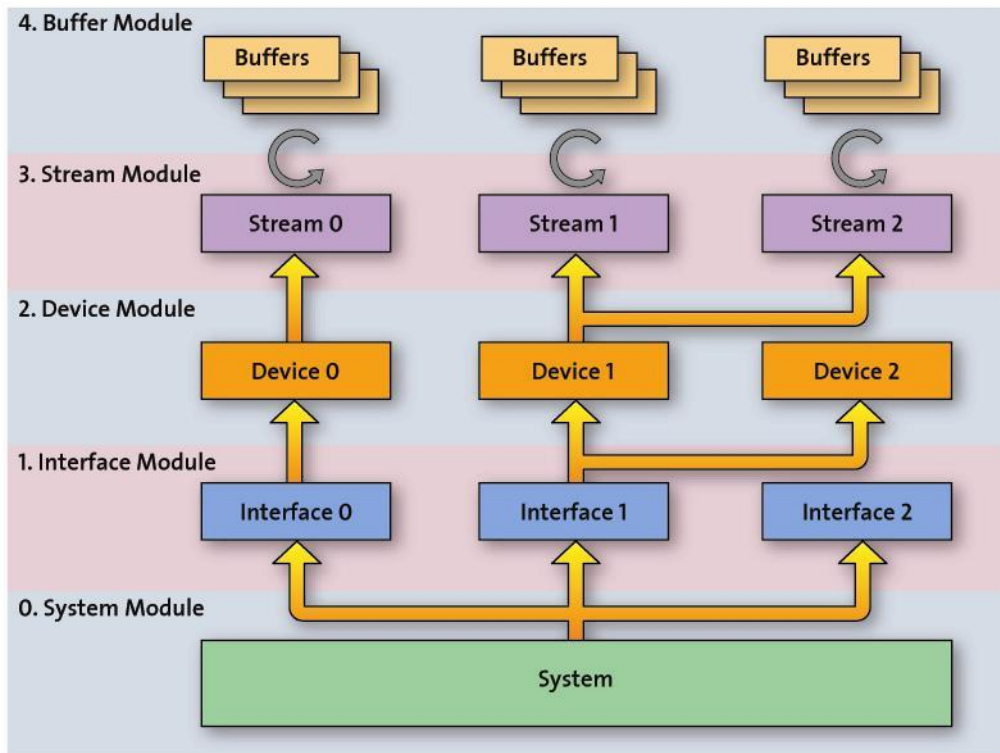

Figure 2-2: GenTL Module hierarchy

2.2.1 System Module

For every GenTL Consumer the System module as the root of the hierarchy is the entry point to a GenTL Producer software driver. It represents the whole system (not global, just the whole system of the GenTL Producer driver) on the host side from the GenTL libraries point of view.

The main task of the System module is to enumerate and instantiate available interfaces covered by the implementation.

The System module also provides signaling capability and configuration of the module's internal functionality to the GenTL Consumer.

It is possible to have a single GenTL Producer incorporating multiple transport layer technologies and to express them as different Interface modules. In this case the transport layer technology of the System module must be 'Mixed' and the child Interface modules expose their actual transport layer technology. In this case the first interface could then be a Camera Link frame grabber board and the second interface an IIDC 1394 controller.

2.2.2 Interface Module

An Interface module represents one physical interface in the system. For Ethernet based transport layer technologies this would be a Network Interface Card (NIC); for a Camera Link based implementation this would be one frame grabber board. The enumeration and instantiation of available devices on this interface is the main role of this module. The

| | | |
|-----------------------|----------------|---|
| GEN<i>i</i>CAM | |  |
| Version 1.4 | GenTL Standard | |

Interface module also presents Signaling and module configuration capabilities to the GenTL Consumer.

One system may contain zero, one or multiple interfaces. An interface is always only of one transport layer technology. It is not allowed to have e.g. a GigE Vision camera and a Camera Link camera on one interface. There is no logical limitation on the number of interfaces addressed by the system. This is limited solely by the hardware used.

2.2.3 Device Module

The Device module represents the GenTL Producers' proxy for one physical remote device. The responsibility of the Device module is to enable the communication with the remote device and to enumerate and instantiate Data Stream modules. The Device module also presents Signaling and module configuration capabilities to the GenTL Consumer.

One Interface module can contain zero, one or multiple Device module instances. A device is always of one transport layer technology. There is no logical limitation on the number of devices attached to an interface. This is limited solely by the hardware used.

2.2.4 Data Stream Module

A single (image) data stream from a remote device is represented by the Data Stream module. The purpose of this module is to provide the acquisition engine and to maintain the internal buffer pool. Beside that the Data Stream module also presents Signaling and module configuration capabilities to the GenTL Consumer.

One device can contain zero, one or multiple data streams. There is no logical limitation on the number of streams a device can have. This is limited solely by the hardware used and the implementation.

2.2.5 Buffer Module

The Buffer module encapsulates a single memory buffer. Its purpose is to act as the target for acquisition. The memory of a buffer can be user allocated or GenTL Producer allocated. The latter could be pre-allocated system memory. The Buffer module also presents Signaling and module configuration capabilities to the GenTL Consumer.

To enable streaming of data at least one buffer has to be announced to the Data Stream module instance and placed into the input buffer pool.

The GenTL Producer may implement preprocessing of the image data which changes image format or buffer size. Please refer to chapter 4.3 for a detailed list of the parameters describing the buffer.

2.3 GenTL Module Common Parts

Access and compatibility between GenTL Consumers and GenTL Producers is ensured by the C interface and the description of the behavior of the modules, the Signaling, the Configuration and the acquisition engine.

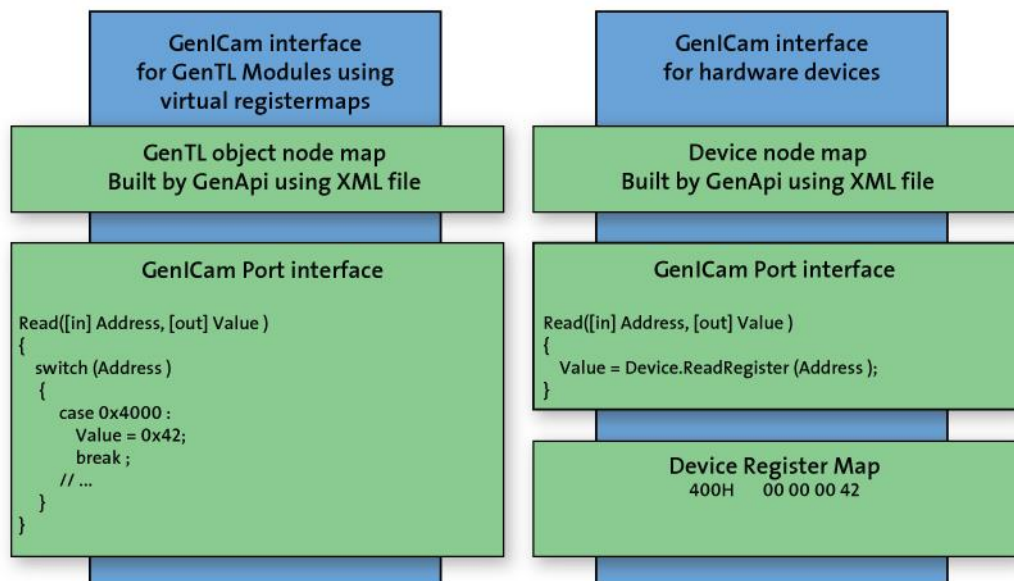

Figure 2-3: GenICam GenTL interface (C and GenApi Feature-interface)

The GenTL Producer driver consists of three logical parts: the C interface, the Configuration interface and the Event interface (signaling). The interfaces are detailed as follows:

2.3.1 C Interface

The C interface provides the entry point of the GenTL Producer. It enumerates and creates all module instances. It includes the acquisition handled by the Data Stream module. The Signaling and Configuration interfaces of the module are also accessed by GenTL Consumer through the C interface. Thus it is possible to stream an image by just using the C interface independent of the underlying technology. This also means that the default state of a GenTL Provider should ensure the ability to open a device and receive data from it.

A C interface was chosen because of multiple reasons:

- **Support of multiple client languages:** a C interface library can be imported by many programming languages. Basic types can be marshaled easily between the languages and modules (different heaps, implementation details).
- **Dynamic loading of libraries:** it is easily possible to dynamically load and call C style functions. This enables the implementation of a GenTL Consumer dynamically loading one or more GenTL Producers at runtime.
- **Upgradeability:** a C library can be designed in a way that it is binary compatible to earlier versions. Thus the GenTL Consumer does not need to be recompiled if a version change occurs.

| | | |
|------------------------|----------------|---|
| GEN<i>CAM | |  |
| Version 1.4 | GenTL Standard | |

Although a C interface was chosen because of the reasons mentioned above, the actual GenTL Producer implementation can be done in an object-oriented language. Except for the global functions, all interface functions work on handles which can be mapped to objects.

Any programming language which can export a library with a C interface can be used to implement a GenTL Producer.

To guarantee interchangeability of GenTL Producers and GenTL Consumers no language specific feature except the ones compatible to ANSI C may be used in the interface of the GenTL Producer.

2.3.2 Configuration

Each module provides GenTL Port functionality so that the GenICam GenApi (or any other similar, non-reference implementations) can be used to access a module's configuration. The basic operations on a GenTL Producer implementation can be done with the C interface without using specific module configuration. More complex or implementation-specific access can be done via the flexible GenApi Feature interface using the GenTL Port functionality and the provided GenApi XML description.

Each module brings this XML description along with which the module's port can be used to read and/or modify settings in the module. To do that each module has its own virtual register map which can be accessed by the Port functions. Thus the generic way of accessing the configuration of a remote device has been extended to the transport layer modules themselves.

2.3.3 Signaling (Events)

Each module provides the possibility to notify the GenTL Consumer of certain events. As an example, a New Buffer event can be raised/signaled if new image data has arrived from a remote device. The number of events supported for a specific module depends on the module and its implementation.

The C interface enables the GenTL Consumer to register events on a module. The event object used is platform and implementation dependent, but is encapsulated in the C interface.

3 Module Enumeration and Instantiation

The behavior described below is seen from a single process' point of view. A GenTL Producer implementation must make sure that every process that is allowed to access the resources has this separated view on the hardware without the need to know that other processes are involved.

For a detailed description of the C functions and data types see chapter 6 Software Interface page 52ff. For how to configure a certain module or get notified on events see chapter 4 Configuration and Signaling page 30.

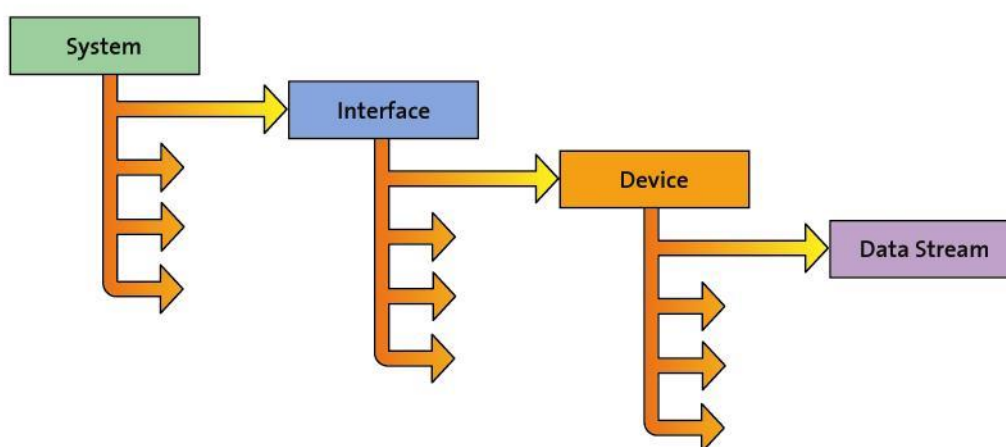

Figure 3-4: Enumeration hierarchy of a GenTL Producer

3.1 Setup

Before the System module can be opened and any operation can be performed on the GenTL Producer driver the [GCInitLib](#) function must be called. This must be done once per process. After the System module has been closed (when e.g. the GenTL Consumer is closed) the [GCCloseLib](#) function must be called to properly free all resources. If the library is used after [GCCloseLib](#) was called the [GCInitLib](#) must be called again.

There is no reference counting within a single process for [GCInitLib](#). Thus even when [GCInitLib](#) is called twice from within a single process space without accompanying call to [GCCloseLib](#), the second call will return an error [GC_ERR_RESOURCE_IN_USE](#). The first call to [GCCloseLib](#) from within that process will free all resources. The same is true for multiple calls to [GCCloseLib](#) without an accompanying call to [GCInitLib](#).

| | | |
|-------------------------------|----------------|--|
| GEN<i><i></i>CAM | |  emva |
| Version 1.4 | GenTL Standard | |

3.2 System

The System module is always the entry point for the calling GenTL Consumer to the GenTL Producer. With the functions present here, all available hardware interfaces in the form of an Interface module can be enumerated.

By calling the [TLOpen](#) function the `TL_HANDLE` to work on the System module's functions can be retrieved. The `TL_HANDLE` obtained from a successful call to the [TLOpen](#) function will be needed for all successive calls to other functions belonging to the System module.

Before doing that, the [GCGetInfo](#) function might be called to retrieve the basic information about the GenTL Producer implementation without opening the system module.

Each GenTL Producer driver exposes only a single System instance in an operating system process space. If a GenTL Producer allows access from multiple processes it has to take care of the inter-process-communication and must handle the book-keeping of instantiated system modules. If it does not allow this kind of access it must return an appropriate error code whenever an attempt to create a second System module instance from another operating system process is made.

The System module does no reference counting within a single process. Thus even when a System module handle is requested twice from within a single process space, the second call will return an error [GC_ERR_RESOURCE_IN_USE](#). The first call to the close function from within that process will free all resources and shut down the module.

Prior to the enumeration of the child interfaces the [TLUpdateInterfaceList](#) function must be called. The list of interfaces held by the System module must not change its content unless this function is called again. Any call to [TLUpdateInterfaceList](#) does not affect instantiated interface handles. It may only change the order of the internal list accessed via [TLGetInterfaceID](#). The instantiation of a child interface with a known id is possible without a previous enumeration. It is recommended to call [TLUpdateInterfaceList](#) after reconfiguration of the System module to reflect possible changes.

The GenTL Consumer must make sure that calls to the [TLUpdateInterfaceList](#) function and the functions accessing the list are not made concurrent from multiple threads and that all threads are aware of the update operation, when performed. The GenTL Producer must make sure that any list access is done in a thread safe way.

After the list of available interfaces has been generated internally the [TLGetNumInterfaces](#) function retrieves the number of present interfaces known to this system. The list contains not the `IF_HANDLES` itself but their unique IDs of the individual interfaces. To retrieve such an ID the [TLGetInterfaceID](#) function must be called. This level of indirection allows the enumeration of several interfaces without the need to open them which can save resources and time.

If additional information is needed to be able to decide which interface is to be opened, the [TLGetInterfaceInfo](#) function can be called. This function enables the GenTL Consumer to query information on a single interface without opening it.

To open a specific interface the unique ID of that interface is passed to the [TLOpenInterface](#) function. If an ID is known prior to the call this ID can be used to

| | | |
|-----------------------|----------------|---|
| GEN<i>i</i>CAM | |  |
| Version 1.4 | GenTL Standard | |

directly open an interface without inquiring the list of available interfaces via [TLUpdateInterfaceList](#). That implies that the IDs must stay the same in-between two sessions. This is only guaranteed when the hardware does not change in any way. The [TLUpdateInterfaceList](#) function may be called nevertheless for the creation of the System's internal list of available interfaces. A GenTL Producer may call [TLUpdateInterfaceList](#) at module instantiation if needed. [TLUpdateInterfaceList](#) must be called by the GenTL Consumer before any call to [TLGetNumInterfaces](#) or [TLGetInterfaceID](#). After successful module instantiation the [TLUpdateInterfaceList](#) function may be called by the GenTL Consumer so that it is aware of any change in that list. For convenience reasons the GenTL Producer implementation may allow opening an Interface module not only using its unique ID but also with any other defined name. If the GenTL Consumer then requests the ID of such a module, the GenTL Producer must return its unique ID and not the convenience-name used to request the module's handle initially. This allows a GenTL Consumer for example to use the IP address of a network interface (in case of a GigE Vision GenTL Producer driver) to instantiate the module instead of using the unique ID.

When the GenTL Producer driver is not needed anymore the [TLClose](#) function must be called to close the System module and all other modules which are still open and relate to this System.

After a System module has been closed it may be opened again and the handle to the module may be different from the first instantiation.

3.3 Interface

An Interface module represents a specific hardware interface like a network interface card or a frame grabber. The exact definition of the meaning of an interface is left to the GenTL Producer implementation. After retrieving the IF_HANDLE from the System module all attached devices can be enumerated.

The size and order of the interface list provided by the System module can change during runtime only as a result of a call to the [TLUpdateInterfaceList](#) function. Interface modules may be closed in a random order that can differ from the order they have been instantiated in. The module does no reference counting. If an Interface module handle is requested a second time from within one process space the second call will return an error [GC_ERR_RESOURCE_IN_USE](#). A single call from within that process to the [IFClose](#) function will free all resources and shut down the module in that process.

Every interface is identified not by an index but by a System module wide unique ID. The content of this ID is up to the GenTL Producer and is only interpreted by it and must not be interpreted by the GenTL Consumer.

In order to create or update the internal list of all available devices the [IFUpdateDeviceList](#) function may be called. The internal list of devices must not change its content unless this function is called again. It is recommended to call [IFUpdateDeviceList](#) regularly from time to time and after reconfiguration of the Interface module to reflect possible changes.

| | | |
|-------------------------------|----------------|---|
| GEN<i><i></i>CAM | |  |
| Version 1.4 | GenTL Standard | |

The GenTL Consumer must make sure that calls to the [IFUpdateDeviceList](#) function and the functions accessing the list are not made concurrent from multiple threads and that all threads are aware of an update operation. The GenTL Producer must make sure that any list access is done in a thread safe way because the access to the lists could be made from multiple threads and the storage for these lists is not thread local. Therefore updating the list from one thread can affect the index used in another thread.

The number of entries in the internally generated device list can be obtained by calling the [IFGetNumDevices](#) function. Like the interface list of the System module, this list does not hold the DEV_HANDLES of the devices but their unique IDs. To retrieve an ID from the list call the [IFGetDeviceID](#) function. By not requiring a device to be opened to be enumerated, it is possible to use different devices in different processes. This is of course only the case if the GenTL Producer supports the access from different processes.

Before opening a Device module more information about it might be necessary. To retrieve that information call the [IFGetDeviceInfo](#) function.

To open a Device module the [IFOpenDevice](#) function is used. As with the interface ID the device ID can be used, if known prior to the call, to open a device directly by calling [IFOpenDevice](#). The ID must not change between two sessions. The [IFUpdateDeviceList](#) function may be called nevertheless for the creation of the Interface internal list of available devices. [IFUpdateDeviceList](#) must be called before any call to [IFGetNumDevices](#) or [IFGetDeviceID](#). In case the instantiation of a Device module is possible without having an internal device list the [IFOpenDevice](#) may be called without calling [IFUpdateDeviceList](#) before. This is necessary if in a system the devices cannot be enumerated, e.g. a GigE Vision system with a camera connected through a WAN. A GenTL Producer may call [IFUpdateDeviceList](#) at module instantiation if needed. After successful module instantiation the [IFUpdateDeviceList](#) may only be called by the GenTL Consumer so that it is aware of any change in that list. A call to [IFUpdateDeviceList](#) does not affect any instantiated Device modules and its handles, only the order of the internal list may be affected.

For convenience reasons the GenTL Producer implementation may allow to open a Device module not only with its unique ID but with any other defined name. If the GenTL Consumer then requests the ID on such a module, the GenTL Producer must return its unique ID and not the “name” used to request the module’s handle initially. This allows a GenTL Consumer for example to use the IP address of a remote device in case of a GigE Vision GenTL Producer driver to instantiate the Device module instead of using the unique ID.

When an interface is not needed anymore it must be closed with the [IFClose](#) function. This frees the resources of this Interface and all child Device modules still open.

After an Interface module has been closed it may be opened again and the handle to the module may be different from the first instantiation.

| | | |
|------------------------|----------------|---|
| GEN<i>CAM | |  |
| Version 1.4 | GenTL Standard | |

3.4 Device

A Device module represents the GenTL Producer driver's view on a remote device. If the Device is able to output streaming data this module is used to enumerate the available data streams. The number of available data streams is limited first by the remote device and second by the GenTL Producer implementation. Dependent on the implementation it might be possible that only one of multiple stream channels can be acquired or even only the first one.

If a GenTL Consumer requests a Device that has been instantiated from within the same process before and has not been closed, the Interface returns an error. If the instance was created in another process space and the GenTL Producer explicitly wants to grant access to the Device this access should be restricted to read only. The module does no reference counting within one process space. If a Device module handle is requested a second time from within one process space, the second call will return an error [GC_ERR_RESOURCE_IN_USE](#). The first call from within that process to the [DevClose](#) function will free all resources and shut down the module including all child modules in that process.

Every device is identified not by an index but by an Interface module wide unique ID. It is recommended to have a general unique identifier for a specific device. The ID of the GenTL Device module should be different to the remote device ID. The content of this ID is up to the GenTL Producer and is only interpreted by it and not by any GenTL Consumer.

For convenience a GenTL Producer may allow opening a device not only by its unique ID. The other representations may be a user defined name or a transport layer technology dependent ID like for example an IP address for IP-based devices.

To get the number of available data streams the [DevGetNumDataStreams](#) function is called using the `DEV_HANDLE` returned from the Interface module. As with the Interface and the Device lists this list holds the unique IDs of the available streams. The number of data streams or the data stream IDs may not change during a single session. The IDs of the data streams must be fix between all sessions.

To get access to the Port object associated with a Device the function [DevGetPort](#) must be called.

A Data Stream module can be instantiated by using the [DevOpenDataStream](#) function. As with the IDs of the modules discussed before a known ID can be used to open a data stream directly. The ID must not change between different sessions. To obtain a unique ID for a Data Stream call the [DevGetDataStreamID](#) function.

In case a given GenTL Producer does not provide a data stream it must return "0" for the number of available stream channels. In this case a call to [DevOpenDataStream](#) and all data stream related functions which start with a DS in the name will fail. This is then called a "Non Streaming Implementation". It only covers the control layer which is responsible for enumeration and communication with the device.

If a device is not needed anymore call the [DevClose](#) function to free the Device module's resources and its depending child Data Streams if they are still open.

| | | |
|-------------------------------|----------------|---|
| GEN<i><i></i>CAM | |  |
| Version 1.4 | GenTL Standard | |

After a Device module has been closed it may be opened again and the handle to the module may be different from the first instantiation.

3.5 Data Stream

The Data Stream module does not enumerate its child modules. Main purpose of this module is the acquisition which is described in detail in chapter 5 Acquisition Engine page 42ff. Buffers are introduced by the calling GenTL Consumer and thus it is not necessary to enumerate them.

Every stream is identified not by an index but by a Device module wide unique ID. The content of this ID is up to the GenTL Producer and is only interpreted by it and not by any GenTL Consumer.

When a Data Stream module is not needed anymore the [DSClose](#) function must be called to free its resources. This automatically stops a running acquisition, flushes all buffers and revokes them.

Access from a different process space is not recommended. The module does no reference counting. That means that even if a Data Stream module handle is requested a second time from within one process space the second call will return an error [GC_ERR_RESOURCE_IN_USE](#). The first call from within that process to the close function will free all resources and shut down the module in that process.

After a Data Stream module has been closed it may be opened again and the handle to the module may be different from the first instantiation.

3.6 Buffer

A buffer acts as the destination for the data from the acquisition engine.

Every buffer is identified not by an index but by a unique handle returned from the [DSAnnounceBuffer](#) or [DSAllocAndAnnounceBuffer](#) functions.

A buffer can be allocated either by the GenTL Consumer or by the GenTL Producer. Buffers allocated by the GenTL Consumer are made known to the Data Stream module by a call to [DSAnnounceBuffer](#) which returns a `BUFFER_HANDLE` for this buffer. Buffers allocated by the GenTL Producer are retrieved by a call to [DSAllocAndAnnounceBuffer](#) which also returns a `BUFFER_HANDLE`. The two methods must not be mixed on a single Data Stream module. A GenTL Producer must implement both methods even if one of them is of lesser performance. The simplest implementation for [DSAllocAndAnnounceBuffer](#) would be a `malloc` from the platform SDK.

If the same buffer is announced twice on a single stream via a call to [DSAnnounceBuffer](#) an error [GC_ERR_RESOURCE_IN_USE](#) is returned. A buffer may be announced to multiple streams. In this case individual handles for each stream will be returned. In general there is no synchronization or locking mechanism between two streams defined. A GenTL Producer may though provide special functionality to prevent data loss. In case a GenTL Producer is not

| | | |
|-----------------------|----------------|---|
| GEN<i>i</i>CAM | |  |
| Version 1.4 | GenTL Standard | |

able to handle buffers announced to multiple streams it may refuse the announcement and return [GC_ERR_RESOURCE_IN_USE](#).

The required size of the buffer must be retrieved either from the Data Stream module the buffer will be announced to or from the associated remote device (see chapter 5.2.1 for further details).

To allow the acquisition engine to stream data into a buffer it has to be placed into the Input Buffer Pool by calling the [DSQueueBuffer](#) function with the `BUFFER_HANDLE` retrieved through announce functions.

A `BUFFER_HANDLE` retrieved either by [DSAnnounceBuffer](#) or [DSAllocAndAnnounceBuffer](#) can be released through a call to [DSRevokeBuffer](#). A buffer which is still in the Input Buffer Pool or the Output Buffer Queue of the acquisition engine cannot be revoked and an error is returned when tried. A memory buffer must only be announced once to a single stream.

3.7 Enumerated modules list overview

The purpose of this chapter is to highlight possible issues related to the maintenance of the list of GenTL modules (interfaces, devices) available in a system. It provides a summary of principles listed in other chapters of the specification.

While the set of data stream modules implemented by a device is static and stays fixed throughout the lifetime of the GenTL local device module, the lists of interfaces within a system and devices discovered on an interface are dynamic and might be updated on request by the GenTL Consumer.

The explicit request to update the list might be issued through the C interface ([TLUpdateInterfaceList](#), [IFUpdateDeviceList](#) functions) or through corresponding commands (`InterfaceUpdateList`, `DeviceUpdateList`) of the parent module.

It's important to remark that there might be multiple different views of the list of "currently available" modules, which we'll demonstrate on an example of devices discovered on an interface:

- Real devices physically connected to the interface. If a new device is connected at runtime (or powered up), the GenTL Producer might or might not be aware of it. This depends on whether it actively monitors the interface. But it will not be published to the GenTL Consumer through the C interface nor the nodemap, until the Consumer explicitly requests to update the list. Similarly, if the device gets physically disconnected (or powered off), it will not be removed from the list published to the GenTL Consumer ([IFGetNumDevices](#)/`DeviceSelector`) until the next list update is executed.
- The list of devices discovered on a given interface at the time of the last request to update the device list ([IFUpdateDeviceList](#) function or `DeviceUpdateList` command in the nodemap) and published to the GenTL Consumer through the C interface ([IFGetNumDevices](#)) and the nodemap (`DeviceSelector`). While the GenTL Producer maintains just a single list and publishes it identically through both interfaces the two

views might still temporarily differ from the GenTL Consumer's viewpoint. If the list is updated from the nodemap (using DeviceUpdateList command), it is reflected by the nodemap directly through the C interface. If the list is updated from the C interface ([IFUpdateDeviceList](#) function), it might not be reflected by the nodemap directly due to GenApi caching effects. Finally, both views (C interface and nodemaps) might be used by the GenTL Consumer independently. It might be querying information through the C interface about one device, while the user selected (DeviceSelector) a different one in the nodemap.

- Currently opened local device modules, i.e. modules for which the GenTL Consumer owns valid handles ([IFOpenDevice](#)). This is typically a subset of the list published through the C interface and the nodemap. However, the specification requires that instantiated handles are not affected by any list update requests. This means that if a device is physically disconnected at runtime (while the consumer owns a valid handle for it), the handle remains valid, until explicitly closed ([DevClose](#)) – even if most operations upon that handle would simply fail. A request to update the device list would, however, remove such a device from the list published by the parent interface. A module handle becomes implicitly invalid whenever its parent (or grandparent...) module is closed. Note also that the specification allows to open the device ([IFOpenDevice](#), similarly for interfaces) directly using a known device ID (the ID's should be unique and must not change between sessions) without calling [IFUpdateDeviceList](#) first. In this case the GenTL Producer might need to (re)execute the device discovery process on its own to connect to the device, providing the handle to the GenTL Consumer – while the published device list remains unchanged (possibly even empty) until next list-update request.

3.8 Example

This sample code shows how to instantiate the first Data Stream of the first Device connected to the first Interface. Error checking is omitted for clarity reasons.

3.8.1 Basic Device Access

Functions used in this section are listed in subsequent sections.

```
{
    InitLib( );
    TL_HANDLE hTL = OpenTL( );
    IF_HANDLE hIface = OpenFirstInterface( hTL );
    DEV_HANDLE hDevice = OpenFirstDevice( hIface );
    DS_HANDLE hStream = OpenFirstDataStream( hDevice );

    // At this point we have successfully created a data stream on the first
    // device connected to the first interface. Now we could start to
    // capture data...
    CloseDataStream( hStream );
}
```

```

CloseDevice( hDevice );
CloseInterface( hIface );
CloseTL( hTL );
CloseLib( );
}

```

3.8.2 InitLib

Initialize GenTL Producer

```

void InitLib( void )
{
    GCInitLib( );
}

```

3.8.3 OpenTL

Retrieve TL Handle

```

TL_HANDLE OpenTL( void )
{
    TLOpen( hTL );
}

```

3.8.4 OpenFirstInterface

Retrieve first Interface Handle

```

IF_HANDLE OpenFirstInterface( hTL )
{
    TLUpdateInterfaceList( hTL );
    TLGetNumInterfaces( hTL, NumInterfaces );
    if ( NumInterfaces > 0 )
    {
        // First query the buffer size
        TLGetInterfaceID( hTL, 0, IfaceID, &bufferSize );

        // Open interface with index 0
        TLOpenInterface( hTL, IfaceID, hNewIface );
        return hNewIface;
    }
}

```

3.8.5 OpenFirstDevice

Retrieve first Device Handle

```

DEV_HANDLE OpenFirstDevice( hIF )

```

```

{
    IFUpdateDeviceList( hIF );
    IFGetNumDevices( hTL, NumDevices );
    if ( NumDevices > 0 )
    {
        // First query the buffer size
        IFGetDeviceID( hIF, 0, DeviceID, &bufferSize );

        // Open interface with index 0
        IFOpenDevice( hIF, DeviceID, hNewDevice );
        return hNewDevice;
    }
}

```

3.8.6 OpenFirstDataStream

Retrieve first data Stream

```

DS_HANDLE OpenFirstDataStream( hDev )
{
    // Retrieve the number of Data Stream
    DevGetNumDataStreams( hDev, NumStreams );

    if ( NumStreams > 0 )
    {
        // Get ID of first stream using
        DevGetDataStreamID( hDev, 0, StreamID, buffersize );
        // Instantiate Data Stream
        DevOpenDataStream( hDev, StreamID, hNewStream );
    }
}

```

3.8.7 CloseDataStream

Close Data Stream

```

void CloseDataStream ( hStream )
{
    DSClose( hStream );
}

```

3.8.8 CloseDevice

Close Device

```

void CloseDevice( hDevice )
{

```

```
DevClose( hDevice );  
}
```

3.8.9 CloseInterface

Close Interface

```
void CloseInterface( hIface )  
{  
    IFClose( hIface );  
}
```

3.8.10 CloseTL

Close System module

```
void CloseTL( hTL )  
{  
    TLClose( hTL );  
}
```

3.8.11 CloseLib

Shutdown GenTL Producer

```
void CloseLib( void )  
{  
    GCCloseLib( );  
}
```

| | | |
|-----------------------|----------------|---|
| GEN<i>i</i>CAM | |  |
| Version 1.4 | GenTL Standard | |

4 Configuration and Signaling

Every module from the System to the Data Stream supports a GenTL Port for the configuration of the module internal settings and the Signaling to the calling GenTL Consumer. For the Buffer module the GenTL Port is optional.

For a detailed description of the C function interface and data types see chapter 6 Software Interface page 52ff. Before a module can be configured or an event can be registered the module to be accessed must be instantiated. This is done through module enumeration as described in chapter 3 Module Enumeration and Instantiation page 19ff.

4.1 Configuration

To configure a module and access transport layer technology specific settings a GenTL Port with a GenApi compliant XML description is used. The module specific functions' concern is the enumeration, instantiation, configuration and basic information retrieval. Configuration is done through a virtual register map and a GenApi XML description for that register map.

For a GenApi reference implementation's IPort interface the TLI publishes Port functions. A GenApi IPort expects a `Read` and a `Write` function which reads or writes a block of data from the associated device. Regarding the GenTL Producer's feature access each module acts as a device for the GenApi implementation by implementing a virtual register map. When certain registers are written or read, implementation dependent operations are performed in the specified module. Thus the abstraction made for camera configuration is transferred also to the GenTL Producer.

The memory layout of that virtual register map is not specified and thus it is up to the GenTL Producer's implementation. A certain set of mandatory features must be implemented which are described in chapter 7, Standard Feature Naming Convention for GenTL (GenTL SFNC) page 138ff.

Among the Port functions of the C interface is a [GCReadPort](#) function and a [GCWritePort](#) function which can be used to implement an IPort object for the GenApi implementation. These functions resemble the IPort `Read` and `Write` functions in their behavior.

Register access through the Port functions is always byte aligned. In case the underlying technology does not allow byte aligned access the GenTL Producer must simulate that by reading more bytes than requested and returning only the requested bytes and by doing a read/modify/write access to the ports register map.

4.1.1 Modules

Every GenTL module except the Buffer module must support the Port functions of the TLI – the Buffer module can support these functions. To access the registers of a module the [GCReadPort](#) and [GCWritePort](#) functions are called on the module's handle, for example on the `TL_HANDLE` for the System module. A GenApi XML description file and the GenApi Module of GenICam is used to access the virtual register map in the module using GenApi features.

| | | |
|-------------------------------|----------------|---|
| GEN<i><i></i>CAM | |  |
| Version 1.4 | GenTL Standard | |

The URL containing the location of the according GenICam XML description can be retrieved through calls to the [GCGetNumPortURLs](#) and [GCGetPortURLInfo](#) functions of the C interface.

Additional information about the actual port implementation in the GenTL Producer can be retrieved using [GCGetPortInfo](#). The information includes for example the port endianness or the allowed access (read/write, read only,...).

Two modules are special in the way the Port access is handled:

4.1.1.1 Device Module

In the Device module two ports are available: First the Port functions can be used with a `DEV_HANDLE` giving access to the Device module's internal features. Second the GenTL Consumer can get the `PORT_HANDLE` of the remote device by calling the [DevGetPort](#) function.

Both Ports are mandatory for a GenTL Producer implementation.

4.1.1.2 Buffer Module

The implementation of the Port functions is not mandatory for buffers. To check if an implementation is available call the [GCGetPortInfo](#) function with e.g. the `PORT_INFO_MODULE` command. If no implementation is present the function's return value must be [GC_ERR_NOT_IMPLEMENTED](#).

4.1.2 XML Description

The only thing missing to be able to use the GenApi like feature access is the XML description. To retrieve a list with the possible locations of the XML the [GCGetNumPortURLs](#) function and the [GCGetPortURLInfo](#) function can be called. Three possible locations are defined in a URL like notation (for a definition on the URL see RFC 3986): Module Register Map (recommended for GenTL Producer), Local Directory or Vendor Web Site. A GenTL Consumer is required to implement 'Module Register Map' and 'Local Directory'. The download from a vendor's website is optional.

Supported formats are:

- Uncompressed XML description files
- Zip-compressed XML description files. The compression methods used are DEFLATE and STORE as described in RFC 1951.

4.1.2.1 Module Register Map (Recommended)

A URL in the form `“local:[///]filename.extension;address;length[?SchemaVersion=x.x.x]”` indicates that the XML description file is located in the module's virtual register map. The square brackets are optional. The “x.x.x” stands for the schema version the referenced XML complies to in the form major.minor.subminor. If the SchemaVersion is omitted the URL references to an XML referring to SchemaVersion 1.0.0. This optional Schema Version is only to be used with the legacy function [GCGetPortURL](#). For current implementations the

| | | |
|-----------------------|----------------|---|
| GEN<i>i</i>CAM | |  |
| Version 1.4 | GenTL Standard | |

[GCGetPortURLInfo](#) function is used to obtain the Schema Version for a specific XML file. Optionally the “//” behind “local:” can be omitted to be compatible to the Gige Vision local format.

If the XML description is stored in the local register map the document can be read by calling the [GCReadPort](#) function.

Entries in italics must be replaced with actual values as follows:

Table 4-1: Local URL definition for XML description files in the module register map

| Entry | Description |
|----------------------|--|
| <i>local</i> | Indicates that the XML description file is located in the virtual register map of the module. |
| <i>filename</i> | Information file name. It is recommended to put the vendor, model/device and version information in the file name separated by an underscore. For example: ‘tlguru_system_rev1’ for the first version of the System module file of the GenTL Producer company TLGuru. |
| <i>extension</i> | Indicates the file type. Allowed types are <ul style="list-style-type: none"> • ‘xml’ for an uncompressed XML description file. • ‘zip’ for a zip-compressed XML description file. |
| <i>address</i> | Start address of the file in the virtual register map. It must be expressed in hexadecimal form without a prefix. |
| <i>length</i> | Length of the file in bytes. It must be expressed in hexadecimal form without a prefix. |
| <i>SchemaVersion</i> | Version the referenced XML complies to. The version is specified as a major.minor.subminor. This only concerns the legacy GCGetPortURL function since the old mechanism has no other ways to report a schema version for the XML file. For the new GCGetPortURLInfo function the schema version should be retrieved through the info commands. |

A complete local URL would look like this:

```
local:tlguru_system_rev1.xml;F0F00000;3BF?SchemaVersion=1.0.0
```

This file has the information file name “tlguru_system_rev1.xml” and is located in the virtual register map starting at address 0xF0F00000 (C style notation) with the length of 0x3BF bytes.

The memory alignment is not further restricted (byte aligned) in a GenTL module. If the platform or the transport layer technology requests a certain memory alignment it has to be taken into account in the GenTL Producer implementation.

| | | |
|-------------------------------|----------------|---|
| GEN<i><i></i>CAM | |  |
| Version 1.4 | GenTL Standard | |

4.1.2.2 Local Directory

URLs in the form “*file:///filepath.extension[?SchemaVersion=1.0.0]*” or “*file:filename.extension[?SchemaVersion=1.0.0]*” indicate that a file is present somewhere on the machine running the GenTL Consumer. This notation follows the URL definition as in the RFC 3986 for local files. Entries in italics must be replaced with the actual values, for example:

```
file:///C:\program%20files/genicam/xml/genapi/tlguru/tlguru_system_rev1.xml?
SchemaVersion=1.0.0
```

This would apply to an uncompressed XML file on an English Microsoft Windows operating system’s C drive.

Optionally the “*///*” behind the “*file:*” can be omitted to be compatible with the GigE Vision notation. This notation does not specify the exact location. A graphical user interface then would show a file dialog for example.

In order to comply with some Windows notations it is also allowed to replace the ‘*|*’ after the drive letter with a ‘*:*’.

It is recommended to put the vendor, model or device and version information in the file name separated by an underscore. For example: *tlguru_system_rev1* for the first version of the System module file of the GenTL Producer company TLGuru.

Supported extensions are:

- ‘*xml*’ for uncompressed XML description files
- ‘*zip*’ for zip-compressed XML description files

4.1.2.3 Vendor Web Site (optional)

If a URL in the form “*http://host/path/filename.extension[?SchemaVersion=1.0.0]*” is present, it indicates that the XML description document can be downloaded from the vendor’s web site. This notation follows the URL definition as in the RFC 3986 for the http protocol. Entries in italics must be replaced with the actual values, e.g.

```
http://www.tlguru.org/xml/tlguru_system_rev1.xml
```

This would apply to an uncompressed XML file found on the web site of the TLGuru company in the xml sub directory.

It is recommended to put the vendor, model or device and version information in the file name separated by an underscore. For example: *tlguru_system_rev1* for the first version of the System module file of the GenTL Producer company TLGuru.

Supported extensions are:

- *xml* for uncompressed XML description files
- *zip* for zip-compressed XML description files

4.1.3 Example

```
{
  // Retrieve the number of available URLs
```

```

GCGetNumPortURLs( hModule, NumURLs );
for( i=0; i<NumURLs; i++ )
{
    URLSize = 0;
    GCGetPortURLInfo( hModule, i, URL_INFO_URL, 0, 0, &URLSize );

    // Retrieve an string buffer to store the URL
    GCGetPortURLInfo( hModule, i, URL_INFO_URL, 0, pURL, &URLSize );

    if ( ParseURLLocation( pURL ) == local )
    {
        // Retrieve the address within the module register map from the URL
        Addr = ParseURLLocalAddress( pURL );
        Length = ParseURLLocalLength( pURL );
        // Retrieve an XMLBuffer to store the XML with the size Length
        ...
        // Load xml from local register map into memory
        GCReadPort( hModule, Addr, XMLBuffer, Length );
    }
}
}

```

4.2 Signaling

The Signaling is used to notify the GenTL Consumer on asynchronous events. Usually all the communication is initiated by the GenTL Consumer. With an event the GenTL Consumer can get notified on specific GenTL Producer operations. This mechanism is an implementation of the observer pattern where the calling GenTL Consumer is the observer and the GenTL Producer is being observed.

The reason why an event object approach was chosen rather than callback functions is mainly thread priority problems. A callback function to signal the arrival of a new buffer is normally executed in the thread context of the acquisition engine. Thus all processing in this callback function is done also with its priority. If no additional precautions are taken the acquisition engine is blocked as long the callback function does processing.

By using an event-object-based approach the acquisition engine for example only prepares the necessary data and then signals its availability to the GenTL Consumer through the previously registered event objects. The GenTL Consumer can decide in which thread context and with which priority the data processing is done. Thus processing of the event and the signal's generation are decoupled.

4.2.1 Event Objects

Event objects allow asynchronous signaling to the calling GenTL Consumer.

Event objects have two states: signaled or not signaled. An [EventGetData](#) function blocks the calling thread until either a user defined timeout occurred or the event object is signaled or the wait is terminated by the GenTL Consumer. If the event object is signaled prior to the call of the [EventGetData](#) functions, the function returns immediately delivering the data associated with the event signaled.

Not every event type can be registered with every module and not every module needs to implement every possible event type. If a module is not listed for an event it does not have to be implemented in that module's implementation.

The maximum size of the data delivered by an event is defined in the event description and can be retrieved through the [EventGetInfo](#) function. The actual size is returned by the [EventGetData](#) function, which retrieves the event.

There are no mandatory event types. If an event type is not implemented in a GenTL Producer the [GCRegisterEvent](#) should return [GC_ERR_NOT_IMPLEMENTED](#). If an event type is implemented by a GenTL Producer module it is recommended to register an event object for that event type. The following event types are defined:

Table 4-2: Event types per module

| Event Type | Modules | Description |
|--------------------|--------------|---|
| Error | All | A GenTL Consumer can get notified on asynchronous errors in a module. These are not errors due to function calls in the C interface or in the GenApi Feature access. These have their own error reporting. This event applies for example to an error while data is acquired in the acquisition engine of a Data Stream module. |
| New Buffer | Data Stream | New data is present in a buffer in the acquisition engine. In case the New Buffer event is implemented it must be registered on a Data Stream module. After registration the calling GenTL Consumer is informed about every new buffer in that stream. If the EventFlush function is called all buffers in the output buffer queue are discarded. If a DSFlushQueue is called all events from the event queue are removed as well. Please use the BUFFER_INFO_IS_QUEUED info command in order to inquire the queue state of a buffer. |
| Feature Invalidate | Local Device | This event signals to a calling GenTL Consumer that the GenTL Producer driver changed a value in the register map of the remote device and if this value is cached in the GenApi implementation the cache must be invalidated. This is especially useful with remote devices where the GenTL Producer may change some information that is also used by the GenTL Consumer. For the |

| Event Type | Modules | Description |
|---------------------|--------------|---|
| | | <p>local modules this is not necessary as the implementation knows which features must not be cached. The use of this mechanism implies that the user must make sure that all terminal nodes the feature depends on are invalidated in order to update the GenApi cache. The provided feature name may not be standardized in SFNC. In case the feature is covered through SFNC the correct SFNC name should be used by the GenTL Producer. In case the provided feature name is under a selector the GenTL Consumer must walk through all selector values and invalidate the provided feature and all nodes it depends on for every selector value.</p> |
| Feature Change | Local Device | <p>This event communicates to a GenTL Consumer that a GenApi feature must be set to a certain value. This is for now only intended for the use in combination with the “TLParamsLocked” standard feature. Only the GenTL Producer knows when stream related features must be locked. This event signals the lock ‘1’ or unlock ‘0’ of that feature. Future use cases might be added when appropriate.</p> <p>The value of a specified feature is changed via its IValue interface, thus a string information is set. No error reporting is done. If that feature is not set or an error occurs no operation is executed and the GenTL Producer is not informed.</p> |
| Remote Device Event | Local Device | <p>This event communicates to a calling GenTL Consumer that a GenApi understandable event occurred, initiated by the Remote Device. The event ID and optional data delivered with this event can be put into a GenApi Adapter which then invalidates all related nodes.</p> <p>This event used to be called Feature Device Event but has been renamed in order to be in sync with the enumeration for the event type.</p> |
| Module Event | All | <p>This event communicates to a calling GenTL Consumer that a GenApi understandable event occurred, initiated by the GenTL Producer module the event was registered on. The event ID and optional data delivered with this event can be put into a GenApi Adapter which then invalidates all related nodes.</p> |

| | | |
|-----------------------|----------------|---|
| GEN<i>i</i>CAM | |  |
| Version 1.4 | GenTL Standard | |

4.2.2 Event Data Queue

The event data queue is the core of the Signaling. This is a thread safe queue holding event type specific data. Operations on this queue must be locked for example via a mutex in a way that its content may not change when either one of the event functions is accessing it or the module specific thread is accessing it. The GenTL Producer implementation therefore must make sure that access to the queue is as short as possible. Alternatively a lock free queue can be used which supports dequeue operations from multiple threads.

An event object' state is signaled as long as the event data queue is not empty.

Each event data queue must have its own lock if any to secure the state of each instance and to achieve necessary parallelism. Both read and write operations must be locked. The two operations of event data retrieval and the event object signal state handling in the [EventGetData](#) function must be atomic. Meaning that, if a lock is used, the lock on the event data queue must be maintained over both operations. Also the operation of putting data in the queue and the event object's state handling must be atomic.

4.2.3 Event Handling

The handling of the event objects is always the same independently of the event type. The signal reason and the signal data of course depend on the event type. The complete state handling is done by the GenTL Producer driver. The GenTL Consumer may call the [EventKill](#) function to terminate a single instance of a waiting [EventGetData](#) operation. This means that if more than one thread waits for an event, the [EventKill](#) function terminates only one wait operation and other threads will continue execution.

4.2.3.1 Registration

Before the GenTL Consumer can be informed about an event, the event object must be registered. After a module instance has been created in the enumeration process an event object can be created with the [GCRegisterEvent](#) function. This function returns a unique `EVENT_HANDLE` which identifies the registered event object. To get information about a registered event the [EventGetInfo](#) function can be used. There must be only one event registered per module and event type. If an event object is registered twice on the same module the [GCRegisterEvent](#) function must return an error `GC_ERR_RESOURCE_IN_USE`.

To unregister an event object the [GCUnregisterEvent](#) function must be called. If a module is closed all event registrations are automatically unregistered. Events that are still in the queue while an event object is unregistered are silently discarded. Pending wait operations through calls to [EventGetData](#) are terminated with a `GC_ERR_ABORT` when the event object is unregistered through [GCUnregisterEvent](#).

After an `EVENT_HANDLE` is obtained the GenTL Consumer can wait for the event object to be signaled by calling the [EventGetData](#) function. Upon delivery of an event, the event object carries data. This data is copied into a GenTL Consumer provided buffer when the call to [EventGetData](#) was successful.

| | | |
|-----------------------|----------------|---|
| GEN<i>i</i>CAM | |  |
| Version 1.4 | GenTL Standard | |

4.2.3.2 Notification and Data Retrieval

If the event object is signaled, data was put into the event data queue at some point in time. The [EventGetData](#) function can be called to retrieve the actual data. As long as there is only one listener thread this function always returns the stored data or, if no data is available waits for an event being signaled with the provided timeout. If multiple listener threads are present only one of them returns with the event data while the others stay in a waiting state until either a timeout occurs, [EventKill](#) is issued or until the next event data becomes available. If [EventKill](#) is called exactly one call to [EventGetData](#) will return [GC_ERR_ABORT](#) even if [EventKill](#) is called while no [EventGetData](#) call was waiting. Also the return of [GC_ERR_ABORT](#) has higher priority than delivering the next event from the queue so that even if there are one or more events in the queue ready to be delivered to the user through a call to [EventGetData](#), after a call to [EventKill](#) the next call to [EventGetData](#) will return [GC_ERR_ABORT](#). In this case no event is removed from the queue and no data is delivered to the GenTL Consumer. The counter [EVENT_NUM_FIRED](#) is not affected by the calls to [EventKill](#).

In case an event object is unregistered through a call to [GCUnregisterEvent](#)'s previous state is lost. This also applies to previous calls to the [EventKill](#) function. When re-registering an event through a call to [GCRegisterEvent](#) on this port later on [EventGetData](#) will not return [GC_ERR_ABORT](#) until [EventKill](#) is called again.

When data is read with this function the data is removed from the queue. Afterwards the GenTL Producer implementation checks whether the event data queue is empty or not. If there is more data available the event object stays signaled and next the call to [EventGetData](#) will deliver the next queue entry. Otherwise the event object is reset to not signaled state. The maximum size of the buffer delivered through [EventGetData](#) can be queried using [EVENT_SIZE_MAX](#) with the [EventGetInfo](#) function. The GenTL Consumer must not perform data size queries since a call of [EventGetData](#) with a NULL pointer for the buffer will remove the data from the queue without delivering it. In this case the event counts as fired and the data is discarded.

The exact type of data is dependent on the event type and the GenTL Producer implementation. The data is copied into a user buffer allocated by the GenTL Consumer. The content of the event data can be queried with the [EventGetDataInfo](#) function. The maximum size of the buffer to be filled is defined by the event type and can be queried using [EVENT_INFO_DATA_SIZE_MAX](#) after the buffer is delivered. This information can be queried using the [EventGetInfo](#) function.

The events are handled as described in the following steps:

- Register a DeviceEvent on the corresponding GenTL module.
- Inquire the max needed buffer size.
- Allocate the buffer to receive the event data.

| | | |
|-----------------------|----------------|---|
| GEN<i>i</i>CAM | |  |
| Version 1.4 | GenTL Standard | |

- Wait for the event and data. The structure of the data in the provided buffer is not defined and GenTL Producer dependent. The only exception to that would be the New Buffer event which provides a defined internal struct.
- Extract the data in the buffer using [EventGetDataInfo](#). This step is not necessary in cases when the GenTL Producer knows the contents of the buffer delivered through [EventGetData](#), such as in case of the New Buffer event.
- ...
- Unregister event.
- Deallocate buffer.

As described the content of the buffer retrieved through [EventGetData](#) is GenTL Producer implementation specific and may be parsed using the [EventGetDataInfo](#) function. The only exception to that is the New Buffer event which will return the `EVENT_NEW_BUFFER_DATA` structure.

For the Device Event events ([EVENT_REMOTE_DEVICE](#)) the GenTL Producer must provide two types of information about every single event, so that it can be "connected" to the remote device's nodemap:

- Event ID: queried through [EventGetDataInfo\(EVENT_DATA_ID\)](#). The ID is passed as a string representation of hexadecimal form, for example "CF51" without the leading '0x'. The ID can be also queried directly in numeric form using [EventGetDataInfo\(EVENT_DATA_NUMID\)](#).
- Event data: buffer containing the (optional) data accompanying the event. It must correspond with the data addressable from the remote device nodemap, the beginning of the buffer must correspond with address 0 of the nodemap's event port. For example for GigE Vision devices this is by convention the entire `EVENTDATA` packet, without the 8-byte GVCP header.

Also for the module's events ([EVENT_MODULE](#)) the GenTL Producer must provide two types of information about every single event, so that it can be connected to a module's nodemap:

- Event ID: queried through [EventGetDataInfo\(EVENT_DATA_ID\)](#). The ID is passed as a string representation of hexadecimal form, for example "CF51" without the leading '0x'. The ID can be also queried directly in numeric form using [EventGetDataInfo\(EVENT_DATA_NUMID\)](#).
- Event data: buffer containing the (optional) data accompanying the event. It must correspond with the data addressable from the module's nodemap, the beginning of the buffer must correspond with address 0 of the nodemap's event port, similar to way the [EVENT_REMOTE_DEVICE](#) is working.

| | | |
|-------------------------------|----------------|---|
| GEN<i><i></i>CAM | |  |
| Version 1.4 | GenTL Standard | |

Note: to improve interoperability, it is recommended that for device events based on "standard" event data formats, the buffer delivered through [EventGetData](#) is directly the buffer that can be fed to the corresponding standard GenApi event adapter. For example in case of GigE Vision it would be the entire EVENTDATA packet, including the header.

If queued event data is not needed anymore the queue can be emptied by calling the [EventFlush](#) function on the associated EVENT_HANDLE. To inquire the queue state of a buffer the GenTL Consumer can call [DSGetBufferInfo](#) with the info command [BUFFER INFO IS QUEUED](#).

Signals that occur without a corresponding event object being registered using [GCRegisterEvent](#) are silently discarded.

A single event notification carries one event and its data.

For example a GigE Vision device event sent through the message channel carrying multiple EventIDs in a single packet must result in multiple GenTL Producer events. Each GenTL Producer event will then provide a single GigE Vision EventID.

4.2.4 Example

This sample shows how to register a New Buffer event.

```
{
  GCRegisterEvent(hDS, EVENT_NEW_BUFFER, hNewBufferEvent);
  CreateThread ( AcqFunction );
}
```

4.2.4.1 AcqFunction

```
{
  while( !EndRun )
  {
    EventGetData( hNewBufferEvent, EventData );
    if ( successful )
    {
      // Do something with the new buffer
    }
  }
}
```

4.3 Data Payload Delivery

The GenTL Producer is allowed to modify the image data acquired from the remote device if needed or convenient for the user. Examples of such modifications can be for example a PixelFormat conversion (for example when decoding a Bayer encoded color image) or LinePitch adjustment (elimination of the line padding produced on the remote device).

Whenever a modification leads to a change of basic parameters required to "understand" the image, the GenTL Producer must inform the GenTL Consumer about the modifications. It is mandatory to report the modified values through the [BUFFER INFO CMD](#) commands of the

| | | |
|-----------------------|----------------|---|
| GEN<i>i</i>CAM | |  |
| Version 1.4 | GenTL Standard | |

C interface. The image parameters that must be reported when changed by the GenTL Producer are:

- Width, Height (image size)
- X offset, Y offset (AOI offsets)
- X padding, Y padding (affecting line and frame alignment)
- Pixel format
- Payload type
- Payload size

If a given [BUFFER INFO CMD](#) command is not available, the GenTL Consumer assumes, that the GenTL Producer did not modify the corresponding parameter and that it corresponds to the settings of the remote device. For example if the query for [BUFFER INFO PIXELFORMAT](#) returns an error, meaning that the [BUFFER INFO PIXELFORMAT](#) command is not available, the GenTL Consumer should assume that the GenTL Producer did not modify the pixel format and that the pixel format in the buffer corresponds to the PixelFormat feature value of the remote device.

The only exception among the essential image describing parameters is the payload size value which needs to be known before any buffers are delivered (it is used for buffer allocation). Thus, if the GenTL Producer modifies the payload size it has to report the actual value through the [STREAM INFO PAYLOAD SIZE](#) command, as described in chapter 5.2.1.

It might be useful to report the modifications also through corresponding features of the stream and buffer nodemaps.

The GenTL Producer must take special care when modifying image data within a stream carrying chunk data payload type. Such modifications must not result in a corrupted chunk data layout meaning that the GenTL Producer must reconstruct the chunk buffer.

5 Acquisition Engine

5.1 Overview

The acquisition engine is the core of the GenTL data stream. Its task is the transportation itself, which mainly consists of the buffer management.

As stated before, the goal for the acquisition engine is to abstract the underlying data transfer mechanism so that it can be used, if not for all, then for most technologies on the market. The target is to acquire data coming from an input stream into memory buffers provided by the GenTL Consumer or made accessible to the GenTL Consumer. The internal design is up to the individual implementation, but there are a few directives it has to follow.

As an essential management element a GenTL acquisition engine holds a number of internal logical buffer pools.

5.1.1 Announced Buffer Pool

All announced buffers are referenced here and are thus known to the acquisition engine. A buffer is known from the point when it is announced until it is revoked (removed from the acquisition engine). No buffer may be added to or removed from this pool during acquisition. This also means that a buffer will stay in this pool even when it is delivered to the GenTL Consumer (see below).

The order of the buffers in the pool is not defined. The maximum possible number of buffers in this pool is only limited due to the system resources. The minimum number of buffers in the pool is one or more depending on the technology or the implementation to allow streaming.

5.1.2 Input Buffer Pool

When the acquisition engine receives data from a device it will fill a buffer from this pool. While a buffer is filled it is removed from the pool and if successfully filled, it is put into the output buffer queue. If the transfer was not successful or if the acquisition has been stopped with [ACQ_STOP_FLAGS_KILL](#) specified the buffer is placed into the output buffer queue by default. It is up to the implementor to provide additional buffer handling modes which would hand that partially filled buffer differently.

The order of the buffers in the pool is not defined. Only buffers present in the Announced Buffer Pool can be in this pool. The maximum number of buffers in this pool is the number of announced buffers.

5.1.3 Output Buffer Queue

Once a buffer has been successfully filled, it is placed into this queue. As soon as there is at least one buffer in the output buffer queue a previous registered event object gets signaled and the GenTL Consumer can retrieve the event data and thus can identify the filled buffer.

When the event data is retrieved the associated buffer is removed from the output buffer queue. This also means that the data and thus the buffer can only be retrieved once. After the

| | | |
|-----------------------|----------------|---|
| GEN<i>i</i>CAM | |  |
| Version 1.4 | GenTL Standard | |

buffer is removed from the output buffer queue (delivered) the acquisition engine must not write data into it. Thus this is effectively a buffer locking mechanism.

In order to reuse this buffer a GenTL Consumer has to put the buffer back into the Input Buffer Pool (requeue).

The order of the buffers is defined by the buffer handling mode. Buffers are retrieved by the New Buffer event in a logical first-in-first-out manner. If the acquisition engine does not remove or reorder buffers in the Output Buffer Queue it is always the oldest buffer from the queue that is returned to the GenTL Consumer. Only buffers present in the Announced Buffer Pool which were filled can be in this queue.

5.2 Acquisition Chain

The following description shows the steps to acquire an image from the GenTL Consumer's point of view. Image or data acquisition is performed on the Data Stream module with the functions using the `DS_HANDLE`. Thus before an acquisition can be carried out, an enumeration of a Data Stream module has to be performed (see chapter 3 Module Enumeration page 19ff). For a detailed description of the C functions and data types see chapter 6 Software Interface page 52ff.

Prior to the following steps the remote device and, if necessary (in case a grabber is used), the GenTL Device module should be configured to produce the desired image format. The remote device's `PORT_HANDLE` can be retrieved from the GenTL Device module's [DevGetPort](#) function.

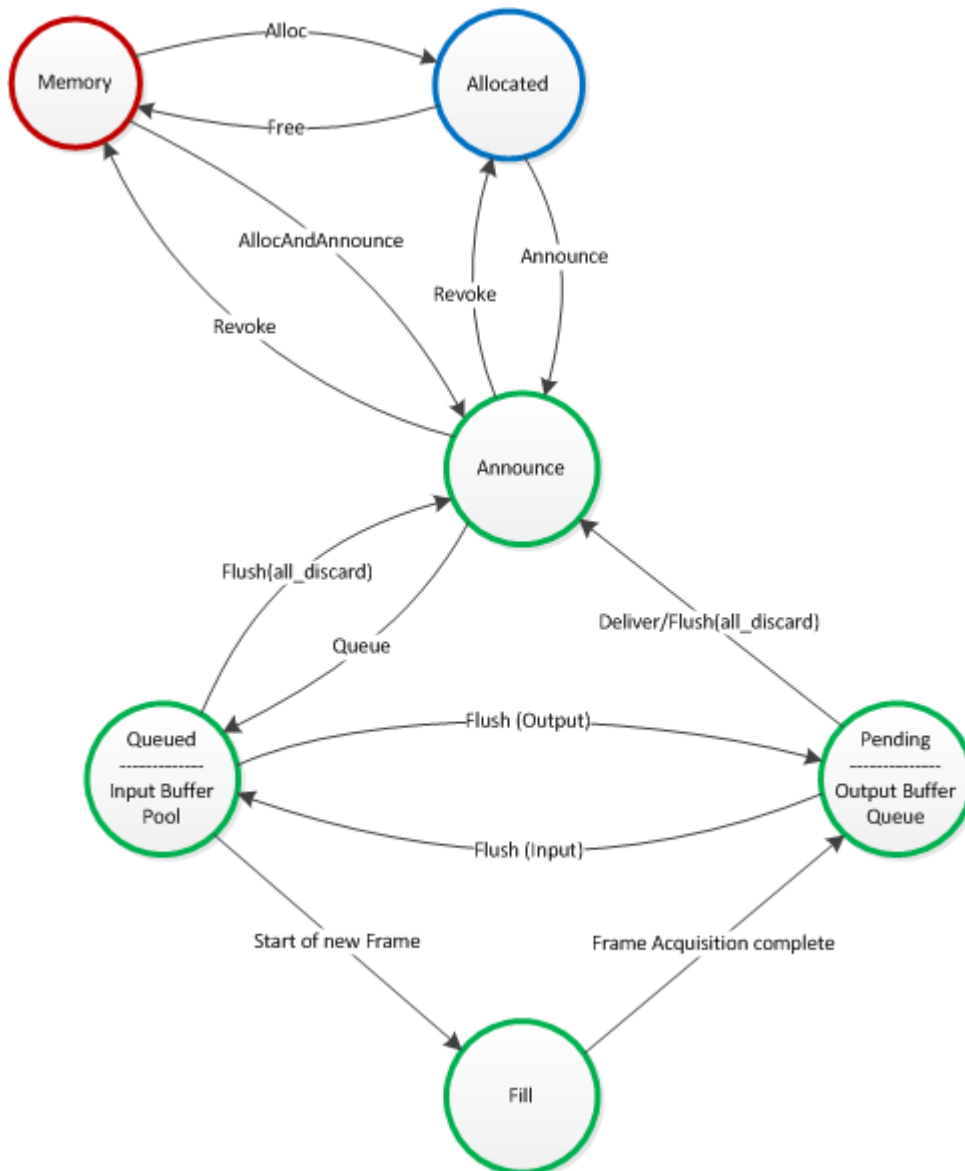

Figure 5-5: Acquisition chain seen from a buffer’s perspective (default buffer handling mode)

5.2.1 Allocate Memory

First the size of a single buffer has to be obtained. In order to obtain that information the GenTL Consumer must query the GenTL Data Stream module (important: not the remote device) to check if the payload size information is provided through the GenTL Producer by calling [DSGetInfo](#) function with the command [STREAM INFO DEFINES PAYLOADSIZE](#). If the returned information is true the Consumer must call [DSGetInfo](#) with [STREAM INFO PAYLOAD SIZE](#) to retrieve the current payload size. Additionally the GenTL Producer may provide a “PayloadSize” feature in the node map of the Data Stream Module reflecting the GenTL Producer’s payload size. The value reported through that feature must be the same as provided through [DSGetInfo](#).

| | | |
|-----------------------|----------------|---|
| GEN<i>i</i>CAM | |  |
| Version 1.4 | GenTL Standard | |

In case the returned information of [DSGetInfo](#) with [STREAM INFO DEFINES PAYLOADSIZE](#) is false the Consumer needs to inquire the PayloadSize through the node map of the remote device. The remote device port can be retrieved via the [DevGetPort](#) function from the according Device module. The GenTL Consumer has to select the streaming channel in the remote device and read the “PayloadSize” standard feature.

In any case the GenTL Producer together with the underlying technology must provide a way to retrieve the payload size. When the device does not provide the PayloadSize feature (for example in case of a GenTL Producer which is implementing an interface standard which is not specifying PayloadSize as a mandatory feature), the GenTL Producer itself must report the required payload size using stream info commands [STREAM INFO DEFINES PAYLOADSIZE](#) and [STREAM INFO PAYLOAD SIZE](#). Failure to query the required payload size would typically disallow the GenTL Consumer to set up the acquisition properly. It might try to calculate the payload size based on the device configuration, but such calculation would never be reliable.

If [STREAM INFO DEFINES PAYLOADSIZE](#) returns true the Data Stream Module must provide the buffer describing parameters. This allows the GenTL Producer to modify the buffer parameters to preprocess an image. In case the GenTL Producer is doing that it must implement all buffer describing parameters. For a detailed description please refer to chapter 4.3.

With that information one or multiple buffers can be allocated as the GenTL Consumer sees fit. The allocation can also be done by the GenTL Producer driver with the combined [DSAllocAndAnnounceBuffer](#) function. If the buffers are larger than requested it does not matter and the real size can be obtained through the [DSGetBufferInfo](#) function.

If the buffers are smaller than requested the error event is fired on the Buffer module (if the error event is implemented on the Buffer module) and on the transmitting Data Stream module with a [GC_ERR_BUFFER_TOO_SMALL](#) error code. It is up to the GenTL Producer if a “too small” buffer is filled with parts of the transferred payload or if the buffer is not filled at all. In both cases the buffer should be delivered to the GenTL Consumer if the underlying technology allows it and the according [BUFFER_INFO_CMDs](#) [BUFFER INFO IS INCOMPLETE](#), [BUFFER INFO SIZE FILLED](#) and [BUFFER INFO DATA LARGER THAN BUFFER](#) should report the fill state. Also in case one or more of the announced buffers are smaller than the payload size the GenTL Producer can refuse to start the acquisition through [DSStartAcquisition](#) returning an error code [GC_ERR_BUFFER_TOO_SMALL](#).

The payload size for each buffer, no matter if defined by the GenTL Producer or by the remote device, may change during acquisition as long as the acquired payload size delivered is smaller than the actual reported at acquisition start. The payload size of a given buffer can be queried through the [BUFFER_INFO_CMDs](#).

5.2.2 Announce Buffers

All buffers to be used in the acquisition engine must be made known prior to their use. Buffers can be added (announced) and removed (revoked) at any time no grab is active.

| | | |
|-----------------------|----------------|---|
| GEN<i>i</i>CAM | |  |
| Version 1.4 | GenTL Standard | |

Along with the buffer memory a pointer to user data is passed which may point to a buffer specific implementation. That pointer is delivered along with the Buffer module handle in the New Buffer event.

The [DSAnnounceBuffer](#) and [DSAllocAndAnnounceBuffer](#) functions return a unique BUFFER_HANDLE to identify the buffer in the process. The minimum number of buffers that must be announced depends on the technology used. This information can be queried from the Data Stream module features. If there is a known maximum this can also be queried. Otherwise the number of buffers is only limited by available memory.

The acquisition engine normally stores additional data with the announced buffers to be able to e.g. use DMA transfer to fill the buffers.

5.2.3 Queue Buffers

To acquire data at least one buffer has to be queued with the [DSQueueBuffer](#) function. When a buffer is queued it is put into the Input Buffer Pool. The user has to explicitly call [DSQueueBuffer](#) to place the buffers into the Input Buffer Pool. The order in which the buffers are queued does not need to match the order in which they were announced. Also the queue order does not necessarily have an influence in which order the buffers are filled. This depends only on the buffer handling mode.

5.2.4 Register New Buffer Event

An event object to the data stream must be registered using the NewBufferEvent ID in order to be notified on newly filled buffers. The [GCRegisterEvent](#) function returns a unique EVENT_HANDLE which can be used to obtain event specific data when the event was signaled. For the “New Buffer” event this data is the BUFFER_HANDLE and the user data pointer.

5.2.5 Start Acquisition

First the acquisition engine on the host is started with the [DSStartAcquisition](#) function. After that the acquisition on the remote device is to be started by setting the “AcquisitionStart” standard feature via the GenICam GenApi.

If a device implements the SFNC Transfer Control features, the GenTL Consumer may need to start the transfer on the remote device as well, depending on the operating mode.

5.2.6 Acquire Image Data

This action is performed in a loop:

- Wait for the “New Buffer” event to be signaled (see 4.2 Signaling page 34ff)
- Process image data
- Requeue buffer in the Input Buffer Pool

With the event data from the signaled event the newly filled buffer can be obtained and then processed. As stated before no assumptions on the order of the buffers are made except that the buffer handling mode defines it.

| | | |
|-------------------------------|----------------|--|
| GEN<i><i></i>CAM | |  emva |
| Version 1.4 | GenTL Standard | |

Requeuing the buffers can be done in any order with the [DSQueueBuffer](#) function. As long as the buffer is not in the Input Buffer Pool or in the Output Buffer Queue the acquisition engine will not write into the buffer. Thus the buffer is effectively locked.

5.2.7 Stop Acquisition

When finished acquiring image data the acquisition on the remote device is to be stopped if necessary. This can be done by setting the “AcquisitionStop” standard feature on the remote device. If it is present the command should be executed. Afterwards the [DSStopAcquisition](#) function is called to stop the acquisition on the host. By doing that the status of the buffers does not change. That implies that a buffer that is in the Input Buffer Pool remains there. The same is true for buffers in the Output Buffer Queue. This has the advantage that buffers which were filled during the acquisition stop process still can be retrieved and processed. If [ACQ STOP FLAGS KILL](#) is specified in the call to [DSStopAcquisition](#) a partially filled buffer is by default moved to the output buffer queue for processing. [DSGetBufferInfo](#) with [BUFFER INFO IS INCOMPLETE](#) would indicate that the buffer is not complete.

If a device implements the SFNC Transfer Control features, the GenTL Consumer may need to stop the transfer on the remote device, depending on the operating mode.

5.2.8 Flush Buffer Pools and Queues

In order to clear the state of the buffers to allow revoking them, the buffers have to be flushed either with the [DSFlushQueue](#) function or with the [EventFlush](#) function. With the [DSFlushQueue](#) function buffers from the Input Buffer Pool can either be flushed to the Output Buffer Queue or discarded. Buffers from the Output Buffer Queue also must either be processed or flushed. Flushing the Output Buffer Queue is done by calling [EventFlush](#) function. Using the [EventFlush](#) function on the “New Buffer” event discards the buffers from the Output Buffer Queue.

5.2.9 Revoke Buffers

To enable the acquisition engine to free all resources needed for acquiring image data, revoke the announced buffers. Buffers that are referenced in either the Input Buffer Pool or the Output Buffer Queue cannot be revoked. After revoking a buffer with the [DSRevokeBuffer](#) function it is not known to the acquisition engine and thus can neither be queued nor receive any image data.

The order in which buffers can be revoked depends on the method in which they were announced. Buffers can be revoked in any order if they were announced by the [DSAnnounceBuffer](#) function. More care has to be taken if the [DSAllocAndAnnounceBuffer](#) function is used. Normally underlying acquisition engines must not change the base pointer to the memory containing the data within a buffer object. If the [DSAllocAndAnnounceBuffer](#) function is used the base pointer of a buffer object may change after another buffer object has been revoked using the [DSRevokeBuffer](#) function. Nevertheless, it is recommended to keep the base pointer of a buffer for the lifetime of the buffer handle.

| | | |
|-----------------------|----------------|---|
| GEN<i>i</i>CAM | |  |
| Version 1.4 | GenTL Standard | |

5.2.10 Free Memory

If the GenTL Consumer provided the memory for the buffers using the [DSAnnounceBuffer](#) function it also has to free it. Memory allocated by the GenTL Producer implementation with [DSAllocAndAnnounceBuffer](#) function is freed by the library if necessary. The GenTL Consumer must not free this memory.

5.3 Buffer Handling Modes

Buffer handling modes describe the internal buffer handling during acquisition. There is only one mandatory default mode. More modes are defined in the GenICam GenTL Standard Feature Naming Convention document.

A certain mode may differ from another in these aspects:

- Which buffer is taken from the Input Buffer Pool to be filled
- At which time a filled buffer is moved to the Output Buffer Queue and at which position it is inserted
- Which buffer in the Output Buffer Queue is overwritten (if any at all) on an empty Input Buffer Pool

The graphical description assumes that we are looking on an acquisition start scenario with five announced and queued buffers B0 to B4 ready for acquisition. When a buffer is delivered the image number is stated below that event. A solid bar on a buffer's time line illustrates its presence in a Buffer pool. A ramp indicates image transfer and therefore transition. During a thin line the Buffer is controlled by the GenTL Consumer and locked for data reception.

5.3.1 Default Mode

The default mode is designed to be simple and flexible with only a few restrictions. This is done to be able to map it to most acquisition techniques used today. If a specific technique cannot be mapped to this mode the goal has to be achieved by copying the data and emulating the behavior in software.

In this scenario every acquired image is delivered to the GenTL Consumer if the mean processing time is below the acquisition time. Peaks in processing time can be mitigated by a larger number of buffers.

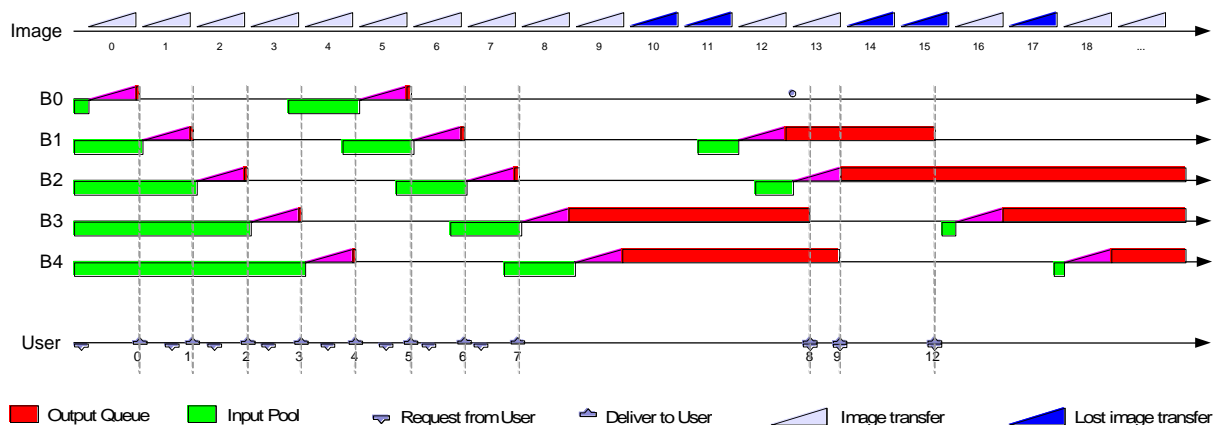

Figure 5-6: Default acquisition from the GenTL Consumer's perspective

The buffer acquired first (the oldest) is always delivered to the GenTL Consumer. No buffer is discarded or overwritten in the Output Buffer Queue. By successive calls to retrieve the event data (and thus the buffers) all filled buffers are delivered in the order they were acquired. This is done regardless of the time the buffer was filled.

It is not defined which buffer is taken from the Input Buffer Pool if new image data is received. If no buffer is in the Input Buffer Pool (e.g. the queuing rate falls behind the transfer rate over a sufficient amount of time), an incoming image will be lost. The acquisition engine will be stalled until a buffer is requested.

Wrap-Up:

- There's no defined order in which the buffers are taken from the Input Buffer Pool.
- As soon as it is filled a buffer is placed at the end of the Output Buffer Queue.
- The acquisition engine stalls if the Input Buffer Pool becomes empty and as long as a buffer is queued.

5.4 Chunk Data Handling

5.4.1 Overview

The GenICam GenApi standard contains a notion of "chunk data". These are chunks of data present in a single buffer acquired from the device together with or without other payload type data. Each chunk is identified unequivocally by its ChunkID (up to 64-bit unsigned integer), which maps it to the corresponding port node in the remote device's XML description file. The information carried by individual chunks is described in the XML file. To address the data in the chunk, the GenApi implementation must know the position (offset) of the chunk in the buffer and its size. The structure of chunk data in the buffer is technology specific and it is therefore the responsibility of the GenTL Producer to parse the chunk data in the buffer (if there are any). To parse a buffer containing chunk data, the consumer uses the function [DSGetBufferChunkData](#), which reports the number of chunks in the buffer and for each chunk its ChunkID, offset and size as an array of [SINGLE_CHUNK_DATA](#) structures. This information is sufficient to connect the chunk to the remote device's nodemap (for example through the generic chunk adapter of GenApi reference implementation).

The acquired buffer might contain only the chunk data or the data might be mixed within the same buffer with an image or other data. To query, if a given buffer contains the chunk data, the [BUFFER_INFO_CONTAINS_CHUNKDATA](#) command may be used which would return a true in case the buffer contains chunk data or the function [DSGetBufferChunkData](#) can be queried which, in case the buffer contains accessible chunk data, would return the number of chunks available.

There are other chunk data related buffer info commands, such as [BUFFER_INFO_IMAGEPRESENT](#) (indicating that the buffer contains also an image) or [BUFFER_INFO_CHUNKLAYOUTID](#) (can help to check, if the chunk structure has changed since the last delivered buffer and if it is necessary to parse it again). The [STREAM_INFO_NUM_CHUNKS_MAX](#) command reports the maximum number of chunks to be expected in a buffer acquired through given stream (if that maximum is known a priori).

In situations when the GenTL Consumer knows the chunk data structure, such as when accessing a device of known standard technology, it's not necessary to use the [DSGetBufferChunkData](#) function to parse the buffer - the GenTL Consumer can use other more direct approach to extract the data (such as using directly a standard chunk adapter in GenApi reference implementation).

5.4.2 Example

```
{
// Check if the buffer contains chunk data
DSGetBufferInfo( hStream, hBuffer, BUFFER_INFO_PAYLOADTYPE, Type, PayloadType,
    SizeOfPayloadType);

if ( PayloadType == PAYLOAD_TYPE_CHUNK_DATA )
{
    ChunkListSize = 0;
    DSGetBufferChunkData( hStream, hBuffer, 0, ChunkListSize )
    {
        // Alternatively it would be possible to inquire the max number of
        // chunks per buffer through STREAM_INFO_NUM_CHUNKS_MAX

        DSGetInfo( hStream, STREAM_INFO_NUM_CHUNKS_MAX, Type, ChunkListSize,
            sizeof(ChunkListSize));

        // In this case the consumer needs error checking in case the
        // GenTL Producer cannot provide that information
    }

// Allocate array of SINGLE_CHUNK_DATA structures
DSGetBufferChunkData( hStream, hBuffer, ChunkArray, ChunkListSize )
```

```
// Pass Chunk Array to GenApi Port  
  
// Free ChunkArray.  
}  
}
```

6 Software Interface

6.1 Overview

A GenTL Producer implementation is provided as a platform dependent dynamic loadable library; under Microsoft Windows platform this would be a dynamic link library (DLL). The file extension of the library is ‘cti’ for “Common Transport Interface”.

To enable easy dynamical loading and to support a wide range of languages a C interface is defined. It is designed to be minimal and complete regarding enumeration and the access to Configuration and Signaling. This enables a quick implementation and reduces the workload on testing.

All functions defined in this chapter are mandatory and must be implemented and exported in the libraries interface; even if no implementation for a function is necessary.

6.1.1 Installation

In order to install a GenTL Producer an installer needs to add the path where the GenTL Producer implementation can be found to a path variable with the name GENICAM_GENTL{32/64}_PATH. The entries within the variable are separated by ‘;’ on Windows and ‘:’ on UNIX based systems. In order to allow different directories for 32Bit and 64Bit implementations residing on the same system two variables are defined: GENICAM_GENTL32_PATH for 32Bit GenTL Producer implementations and GENICAM_GENTL64_PATH for 64Bit GenTL Producer implementations. A consumer may pick the appropriate version of the environment variable.

6.1.2 Function Naming Convention

All functions of the TLI follow a common naming scheme:

Prefix Operation Specifier

Entries in italics are replaced by an actual value as follows:

Table 6-3: Function naming convention

| Entry | Description |
|------------------|--|
| <i>Prefix</i> | <p>Specifies the handle the function works on. The handle represents the module used.</p> <p>Values:</p> <ul style="list-style-type: none"> • GC if applicable for no or all modules (GC for GenICam) • TL for System module (TL for Transport Layer) • IF for Interface module (IF for Interface) • Dev for Device module (Dev for Device) • DS for Data Stream module (DS for Data Stream) • Event for Event Objects |
| <i>Operation</i> | <p>Specifies the operation done on a certain module.</p> <p>Values (choice):</p> <ul style="list-style-type: none"> • Open to open a module |

| | | |
|-----------------------|----------------|---|
| GEN<i>i</i>CAM | |  |
| Version 1.4 | GenTL Standard | |

| Entry | Description |
|------------------|--|
| | <ul style="list-style-type: none"> • Close to close a module • Get to query information about a module or object |
| <i>Specifier</i> | <p>This is optional. If an operation needs additional information, it is provided by the <i>Specifier</i>.</p> <p>Values (choice):</p> <ul style="list-style-type: none"> • xxxInfo to retrieve xxx-object specific information • Numxxx to retrieve the number of xxx-objects |

For example the function [TLGetNumInterfaces](#) works on the System module's TL_HANDLE and queries the number of available interfaces. [TLClose](#) for instance closes the System module.

6.1.3 Memory and Object Management

The interface is designed in a way that objects and data allocated in the GenTL Producer implementation are only freed or reallocated inside the library. Vice versa all objects and data allocated by the calling GenTL Consumer must only be reallocated and freed by the calling GenTL Consumer. No language specific features except the ones allowed by ANSI C and published in the interface are allowed.

The function names of the exported functions must be undecorated. The function calling convention is stdcall for x86 platforms and architecture dependent for other platforms.

This ensures that the GenTL Producer implementation and the calling GenTL Consumer can use different heaps and different memory allocation strategies. Also language interchangeability is easier handled this way.

For functions filling a buffer (e.g. a C string) the function can be called with a NULL pointer for the `char*` parameter (buffer). The *piSize* parameter is then filled with the size of buffer needed to hold the information in bytes. For C strings that does incorporate the terminating 0 character. A function expecting a C string as its parameter not containing a size parameter for it expects a 0-terminated C string. Queries are not allowed for event data.

Objects that contain the state of one module's instance are referenced by handles (`void*`). If a module has been instantiated before and is opened a second time from within a single process an error [GC_ERR_RESOURCE_IN_USE](#) has to be returned. A close on the module will free the resource of the closed module and all underlying or depending child modules. This is true as long as these calls are in the same process space (see below). Thus if a Interface module is closed all attached Device, Data Stream and Buffer modules are also closed.

6.1.4 Thread and Multiprocess Safety

If the platform supports threading, all functions must be thread safe to ensure data integrity when a function is called from different threads in one process. Certain restrictions apply for all list functions like [TLUpdateInterfaceList](#) and [IFUpdateDeviceList](#) since results are cached inside the module.

If a platform supports independent processes the GenTL Producer implementation may establish interprocess communication. Minimal requirement is that other processes are not allowed to use an opened Device module. It is recommended though that a GenTL Producer implementation is multiprocess capable to the point where:

- Access rights for the Modules are checked
An open Device module should be locked against multiple process write access. In that case an error should be returned. Read access may be granted though.
- Data/state safety is ensured
Reference counting must be done so that if e.g. the System module of one process is closed the resources of another process are not automatically freed.
- Different processes can communicate with different devices
Each process should be able to communicate with one or multiple devices. Also different processes should be able to communicate with different devices.

6.1.5 Error Handling

Every function has as its return value a `GC_ERROR`. This value indicates the status of the operation. Functions must give strong exception safety. With an exception not a language dependent exception object is meant, but an execution error in the called function with a return code other than `GC_ERR_SUCCESS`. No exception objects may be thrown of any exported function. Strong exception safety means:

- Data validity is preserved
No data becomes corrupted or leaked.
- State is unchanged
First the internal state must stay consistent and it must be as if the function encountering the error was never called. Therefore the output values of a function are to be handled as if being invalid if the function returns an error code.

This ensures that calling GenTL Consumers always can expect a known state in the GenTL Producer implementation: either it is the desired state when a function call was successful or it is the state the GenTL Producer implementation had before the call.

The following values are defined:

Table 6-4: C interface error codes

| Enumerator | Value | Description |
|-------------------------------------|-------|---|
| <code>GC_ERR_SUCCESS</code> | 0 | Operation was successful; no error occurred. |
| <code>GC_ERR_ERROR</code> | -1001 | Unspecified runtime error. |
| <code>GC_ERR_NOT_INITIALIZED</code> | -1002 | Module or resource not initialized; e.g. GCInitLib was not called . |
| <code>GC_ERR_NOT_IMPLEMENTED</code> | -1003 | Requested operation not implemented; e.g. no Port functions on a Buffer module. |
| <code>GC_ERR_RESOURCE_IN_USE</code> | -1004 | Requested resource is already in use. |

| Enumerator | Value | Description |
|---------------------------|-------|--|
| GC_ERR_ACCESS_DENIED | -1005 | Requested operation is not allowed; e.g. a remote device is opened by another client. |
| GC_ERR_INVALID_HANDLE | -1006 | Given handle does not support the operation; e.g. function call on wrong handle or NULL pointer. |
| GC_ERR_INVALID_ID | -1007 | ID could not be connected to a resource; e.g. a device with the given ID is currently not available. |
| GC_ERR_NO_DATA | -1008 | The function has no data to work on. |
| GC_ERR_INVALID_PARAMETER | -1009 | One of the parameter given was not valid or out of range. |
| GC_ERR_IO | -1010 | Communication error has occurred; for example a read or write operation to a remote device failed. |
| GC_ERR_TIMEOUT | -1011 | An operation's timeout time expired before it could be completed. |
| GC_ERR_ABORT | -1012 | An operation has been aborted before it could be completed. For example a wait operation through EventGetData has been terminated via a call to EventKill . |
| GC_ERR_INVALID_BUFFER | -1013 | The GenTL Consumer has not announced enough buffers to start the acquisition in the currently active acquisition mode. |
| GC_ERR_NOT_AVAILABLE | -1014 | Resource or information is not available at a given time in a current state. |
| GC_ERR_INVALID_ADDRESS | -1015 | A given address is out of range or invalid for internal reasons. |
| GC_ERR_BUFFER_TOO_SMALL | -1016 | A provided buffer is too small to receive the expected amount of data. This may affect acquisition buffers in the Data Stream module if the buffers are smaller than the expected payload size but also buffers passed to any other function of the GenTL Producer interface to retrieve information or IDs. |
| GC_ERR_INVALID_INDEX | -1017 | A provided index referencing a Producer internal object is out of bounds. |
| GC_ERR_PARSING_CHUNK_DATA | -1018 | An error occurred parsing a buffer |

| | | |
|-----------------------|----------------|---|
| GEN<i>i</i>CAM | |  |
| Version 1.4 | GenTL Standard | |

| Enumerator | Value | Description |
|---------------------------|--------|---|
| | | containing chunk data. |
| GC_ERR_INVALID_VALUE | -1019 | A register write function was trying to write an invalid value. |
| GC_ERR_RESOURCE_EXHAUSTED | -1020 | A requested resource is exhausted. This is a rather general error which might for example refer to a limited number of available handles being available. |
| GC_ERR_OUT_OF_MEMORY | -1021 | The system and/or other hardware in the system (Framegrabber) ran out of memory. |
| GC_ERR_CUSTOM_ID | -10000 | Any error smaller or equal than -10000 is implementation specific. If a GenTL Consumer receives such an error number it should react as if it would be a generic runtime error. |

To get a detailed descriptive text about the error reason call the [GCGetLastError](#) function.

Some error codes might be returned by any function and are therefore not explicitly listed in the function's error code table. These error codes are:

- GC_ERR_ERROR
- GC_ERR_IO
- GC_ERR_RESOURCE_EXHAUSTED
- GC_ERR_OUT_OF_MEMORY

6.1.6 Software Interface Versions

The software interface evolves over the individual versions of the GenTL specification. In particular, between two versions of the interface, new functions (and corresponding data structures) and enumerations might be introduced. In rare cases, existing functions or commands might be conversely deprecated. Interface versions are indicated by a major version number and a minor version number in a notation "x.y" with 'x' being the major version number and 'y' being the minor version number.

- **Major Version Numbers**
Different major version numbers indicate major additions to the interface and/or breaking changes. This means for example a removal of functions or a complete new feature set. The newer interface is therefore not backward compatible.
- **Minor Version Numbers**
Changes in the minor version number of the software interface may indicate new functionality and clarifications in the text describing the interface. If only the minor version changes the interface stays backward compatible.
Changing feature names without functional change is also allowed in minor releases.

| | | |
|-----------------------|----------------|---|
| GEN<i>i</i>CAM | |  |
| Version 1.4 | GenTL Standard | |

When developing a GenTL Consumer that should be compatible with a widest range of GenTL Producer versions, special care might be required to consider these differences.

When using an enumeration unknown to the GenTL Producer, the function getting that value as a parameter would return an appropriate error code. For example when querying an unknown info command, the GenTL Producer would return `GC_ERR_NOT_IMPLEMENTED`.

When trying to use a GenTL interface function unknown to the GenTL Producer, the function implementation will be simply missing in the GenTL Producer's binary. For the functions that are not universally available in all GenTL specification versions, the Consumer should check their presence in the GenTL Producer's interface at load time - and if possible, consider a suitable fallback behaviour for GenTL Producers not implementing that function.

6.2 Used Data Types

To have a defined stack layout certain data types have a primitive data type as its base.

6.2.1.1 GC_ERROR

The return value of all functions is a 32 bit signed integer value.

6.2.1.2 Handles

All handles like `TL_HANDLE` or `PORT_HANDLE` are `void*`. The size is platform dependent (e.g. 32 bit on 32 bit platforms)

6.2.1.3 Enumerations

All enumerations are of type `enum`. In order to allow implementation specific extensions all enums are set to a specific 32 bit integer value. On platforms/compiler where this is not the case a primitive data type with a matching size is to be used.

6.2.1.4 Buffers and C Strings

Buffers are normally typed as `void*` if arbitrary data is accessed. Specialized buffers like C strings are by default ASCII encoded and a `char*` is used unless reported different through the type information provided by the info functions (for example [IFGetInfo](#)). A `char` is expected to have 8 bits. On platforms/compiler where this is not the case a byte like primitive data type must be used.

String encoding is by default ASCII (characters with numerical values up to and including 127) unless stated different through the `TL_INFO_CHAR_ENCODING` command. A string as an input value without a size parameter must be 0-terminated. Strings with a size parameter must include the terminating 0.

6.2.1.5 Primitive Data Types

The `size_t` type indicates that a buffer size is represented. This is a platform dependent unsigned integer (e.g. 32 bit on 32 bit platforms).

The `ptrdiff_t` is a signed type which indicates that its value relates to an arithmetic operation with a memory pointer, usually a buffer. It's size is platform dependent (e.g. 32 bit on 32 bit platforms and 64Bit on 64Bit platforms).

The other functions use a notation defining its base type and size. `uint8_t` stands for an unsigned integer with the size of 8 bits. `int32_t` is a signed integer with 32 bits size.

6.3 Function Declarations

6.3.1 Library Functions

6.3.1.1 GCCloseLib

```
GC_ERROR GCCloseLib ( void )
```

This function must be called after no function of the GenTL library is needed anymore to clean up the resources from the [GCInitLib](#) function call. Each call to [GCCloseLib](#) has to be accompanied by a preceding call to [GCInitLib](#).

[GCGetLastError](#) must not be called after the call of this function!

Returns

`GC_ERR_SUCCESS` Operation was successful; no error occurred.

`GC_ERR_NOT_INITIALIZED` No preceding call to [GCInitLib](#)

Error cases not covered in the list above may return error codes according to chapter 6.1.5 Error Handling on page 54.

6.3.1.2 GCGetInfo

```
GC_ERROR GCGetInfo ( TL_INFO_CMD iInfoCmd,
                    INFO_DATATYPE * piType,
                    void * pBuffer,
                    size_t * piSize )
```

Inquire information about a GenTL implementation without instantiating a System module. The available information is limited since the TL is not initialized yet. Even if this function works on a library without an instantiated System module, [GCInitLib](#) must be called prior calling this function.

If the provided buffer is too small to receive all information an error is returned.

Parameters

[in] `iInfoCmd` Information to be retrieved as defined in [TL_INFO_CMD](#).

[out] `piType` Data type of the `pBuffer` content as defined in the [TL_INFO_CMD](#) and [INFO_DATATYPE](#).

[in,out] *pBuffer* Pointer to a user allocated buffer to receive the requested information. If this parameter is NULL, *piSize* will contain the minimal size of *pBuffer* in bytes. If the *iType* is a string the size includes the terminating 0.

[in,out] *piSize* *pBuffer* equal NULL:
 out: minimal size of *pBuffer* in bytes to hold all information
pBuffer unequal NULL:
 in: size of the provided *pBuffer* in bytes
 out: number of bytes filled by the function

Returns

GC_ERR_SUCCESS Operation was successful; no error occurred.

GC_ERR_NOT_INITIALIZED No preceding call to [GCInitLib](#)

GC_ERR_NOT_IMPLEMENTED Specified *iInfoCmd* is not implemented.

GC_ERR_INVALID_PARAMETER Parameters *piSize* and/or *piType* are invalid pointers (NULL or ~0x0)

GC_ERR_BUFFER_TOO_SMALL *pBuffer* is not NULL and the value of **piSize* is too small to receive the expected amount of data.

Error cases not covered in the list above may return error codes according to chapter 6.1.5 Error Handling on page 54.

6.3.1.3 GCGetLastError

```
GC_ERROR GCGetLastError ( GC_ERROR * piErrorCode,
                          char * sErrorText,
                          size_t * piSize )
```

Returns a readable text description of the last error occurred in the local thread context.

If multiple threads are supported on a platform this function must store this information thread local. In case an error occurs and after that several other function calls return without error the last error value and description is returned and the successful calls are ignored. If there has not been any error in the given thread context since startup the function will return GC_ERR_SUCCESS with **piErrorCode* also set to GC_ERR_SUCCESS and *sErrorText* containing “No Error”. In case GCGetLastError itself generates an error it will return the according error code but it will not store the error internally so that succeeding calls to GCGetLastError will still be able to report the stored error code.

Parameters

[out] *piErrorCode* Error code of the last error.

[in,out] *sErrorText* Pointer to a user allocated C string buffer to receive the last error text. If this parameter is NULL, *piSize* will contain the

[in,out] *piSize* needed size of *sErrorText* in bytes. The size includes the terminating 0.
pBuffer equal NULL:
 out: minimal size of *pBuffer* in bytes to hold all information
pBuffer unequal NULL:
 in: size of the provided *pBuffer* in bytes
 out: number of bytes filled by the function

Returns

| | |
|--------------------------|--|
| GC_ERR_SUCCESS | Operation was successful; no error occurred. |
| GC_ERR_NOT_INITIALIZED | No preceding call to GCInitLib |
| GC_ERR_INVALID_PARAMETER | Parameters <i>piSize</i> and/or <i>piErrorCode</i> are invalid pointers (NULL or ~0x0) |
| GC_ERR_BUFFER_TOO_SMALL | <i>sErrorText</i> is not NULL and the value of <i>*piSize</i> is too small to receive the expected amount of data. |

Error cases not covered in the list above may return error codes according to chapter 6.1.5 Error Handling on page 54.

6.3.1.4 GCInitLib

| | |
|--------------------|----------|
| GC_ERROR GCInitLib | (void) |
|--------------------|----------|

This function must be called prior to any other function call to allow global initialization of the GenTL Producer driver. This function is necessary since automated initialization functionality like within `DllMain` on MS Windows platforms is very limited. Multiple calls to [GCInitLib](#) without accompanied calls to [GCCloseLib](#) will return an error `GC_ERR_RESOURCE_IN_USE`.

Returns

| | |
|------------------------|---|
| GC_ERR_SUCCESS | Operation was successful; no error occurred. |
| GC_ERR_RESOURCE_IN_USE | GCInitLib already called without accompanied call to GCCloseLib |

Error cases not covered in the list above may return error codes according to chapter 6.1.5 Error Handling on page 54.

6.3.2 System Functions

6.3.2.1 TLClose

```
GC_ERROR TLClose ( TL_HANDLE hSystem )
```

Closes the System module associated with the given *hSystem* handle. This closes the whole GenTL Producer driver and frees all resources. Call the [GCCloseLib](#) function afterwards if the library is not needed anymore.

Parameters

[in] *hSystem* System module handle to close.

Returns

GC_ERR_SUCCESS Operation was successful; no error occurred.

GC_ERR_NOT_INITIALIZED No preceding call to [GCInitLib](#)

GC_ERR_INVALID_HANDLE The handle *hSystem* is invalid (NULL) or does not reference an open System module retrieved through a call to [TLOpen](#).

Error cases not covered in the list above may return error codes according to chapter 6.1.5 Error Handling on page 54.

6.3.2.2 TLGetInfo

```
GC_ERROR TLGetInfo ( TL_HANDLE hSystem,
                    TL_INFO_CMD iInfoCmd,
                    INFO_DATATYPE * piType,
                    void * pBuffer,
                    size_t * piSize )
```

Inquire information about the System module as defined in `TL_INFO_CMD`.

Parameters

[in] *hSystem* System module to work on.

[in] *iInfoCmd* Information to be retrieved as defined in [TL_INFO_CMD](#).

[out] *piType* Data type of the *pBuffer* content as defined in the [TL_INFO_CMD](#) and [INFO_DATATYPE](#).

[in,out] *pBuffer* Pointer to a user allocated buffer to receive the requested information. If this parameter is NULL, *piSize* will contain the minimal size of *pBuffer* in bytes. If the *piType* is a string the size includes the terminating 0.

[in,out] *piSize* *pBuffer* equal NULL:
out: minimal size of *pBuffer* in bytes to hold all information

pBuffer unequal NULL:
in: size of the provided *pBuffer* in bytes
out: number of bytes filled by the function

Returns

| | |
|--------------------------|--|
| GC_ERR_SUCCESS | Operation was successful; no error occurred. |
| GC_ERR_NOT_INITIALIZED | No preceding call to GCInitLib |
| GC_ERR_INVALID_HANDLE | The handle <i>hSystem</i> is invalid (NULL) or does not reference an open System module retrieved through a call to TLOpen . |
| GC_ERR_NOT_IMPLEMENTED | Specified <i>iInfoCmd</i> is not implemented. |
| GC_ERR_INVALID_PARAMETER | Parameters <i>piSize</i> and/or <i>piType</i> are invalid pointers (NULL or ~0x0) |
| GC_ERR_BUFFER_TOO_SMALL | <i>pBuffer</i> is not NULL and the value of <i>*piSize</i> is too small to receive the expected amount of data. |
| GC_ERR_NOT_AVAILABLE | The request is implemented but the requested information is currently not available for any reason. |

Error cases not covered in the list above may return error codes according to chapter 6.1.5 Error Handling on page 54.

6.3.2.3 TLGetInterfaceID

```
GC_ERROR TLGetInterfaceID ( TL_HANDLE      hSystem,
                           uint32_t      iIndex,
                           char *        sIfaceID,
                           size_t *     piSize )
```

Queries the unique ID of the interface at *iIndex* in the internal interface list. Prior to this call the [TLUpdateInterfaceList](#) function must be called. The list content will not change until the next call of the update function.

This function is not thread safe since it relies on an internal cache.

Parameters

| | |
|--------------------------|---|
| [in] <i>hSystem</i> | System module to work on. |
| [in] <i>iIndex</i> | Zero-based index of the interface on this system. |
| [in,out] <i>sIfaceID</i> | Pointer to a user allocated C string buffer to receive the Interface module ID at the given <i>iIndex</i> . If this parameter is NULL, <i>piSize</i> will contain the needed size of <i>sIfaceID</i> in bytes. The size includes the terminating 0. |
| [in,out] <i>piSize</i> | <i>sIfaceID</i> equal NULL: out: minimal size of <i>sIfaceID</i> in bytes to hold all information |

sifaceID unequal NULL:
in: size of the provided *sifaceID* in bytes
out: number of bytes filled by the function

Returns

- GC_ERR_SUCCESS Operation was successful; no error occurred.
- GC_ERR_NOT_INITIALIZED No preceding call to [GCInitLib](#).
- GC_ERR_INVALID_HANDLE The handle *hSystem* is invalid (NULL) or does not reference an open System module retrieved through a call to [TLOpen](#).
- GC_ERR_INVALID_INDEX *iIndex* is greater than the number of available Interface modules - 1 retrieved through a call to [TLGetNumInterfaces](#).
- GC_ERR_INVALID_PARAMETER Parameter *piSize* is an invalid pointer (NULL or ~0x0)
- GC_ERR_BUFFER_TOO_SMALL *sifaceID* is not NULL and the value of **piSize* is too small to receive the expected amount of data.

Error cases not covered in the list above may return error codes according to chapter 6.1.5 Error Handling on page 54.

6.3.2.4 TLGetInterfaceInfo

```
GC_ERROR TLGetInterfaceInfo ( TL_HANDLE      hSystem,
                             const char *   sifaceID,
                             INTERFACE_INFO_CMD iInfoCmd,
                             INFO_DATATYPE * piType,
                             void *        pBuffer,
                             size_t *      piSize )
```

Inquire information about an interface on the given System module *hSystem* as defined in [INTERFACE_INFO_CMD](#) without opening the interface.

Parameters

- [in] *hSystem* System module to work on.
- [in] *sifaceID* Unique ID of the interface to inquire information from.
- [in] *iInfoCmd* Information to be retrieved as defined in [INTERFACE_INFO_CMD](#).
- [out] *piType* Data type of the *pBuffer* content as defined in the [INTERFACE_INFO_CMD](#) and [INFO_DATATYPE](#).
- [in,out] *pBuffer* Pointer to a user allocated buffer to receive the requested information. If this parameter is NULL, *piSize* will contain the

minimal size of *pBuffer* in bytes. If the *piType* is a string the size includes the terminating 0.

[in,out] *piSize* *pBuffer* equal NULL:
 out: minimal size of *pBuffer* in bytes to hold all information
 pBuffer unequal NULL:
 in: size of the provided *pBuffer* in bytes
 out: number of bytes filled by the function

Returns

| | |
|--------------------------|--|
| GC_ERR_SUCCESS | Operation was successful; no error occurred. |
| GC_ERR_NOT_INITIALIZED | No preceding call to GCInitLib . |
| GC_ERR_INVALID_HANDLE | The handle <i>hSystem</i> is invalid (NULL) or does not reference an open System module retrieved through a call to TLOpen . |
| GC_ERR_NOT_IMPLEMENTED | Specified <i>iInfoCmd</i> is not implemented. |
| GC_ERR_INVALID_PARAMETER | Parameters <i>piSize</i> and/or <i>piType</i> are invalid pointers (NULL or ~0x0). |
| GC_ERR_BUFFER_TOO_SMALL | <i>pBuffer</i> is not NULL and the value of <i>*piSize</i> is too small to receive the expected amount of data. |
| GC_ERR_INVALID_ID | The GenTL Producer is unable to interpret the provided ID string <i>sIfaceID</i> or is not able to match it to an existing Interface. |
| GC_ERR_NOT_AVAILABLE | The request is implemented but the requested information is currently not available for any reason. |

Error cases not covered in the list above may return error codes according to chapter 6.1.5 Error Handling on page 54.

6.3.2.5 TLGetNumInterfaces

| | | | | |
|----------|--------------------|---|------------|----------------------|
| GC_ERROR | TLGetNumInterfaces | (| TL_HANDLE | <i>hSystem</i> , |
| | | | uint32_t * | <i>piNumIfaces</i>) |

Queries the number of available interfaces on this System module. Prior to this call the [TLUpdateInterfaceList](#) function must be called. The list content will not change until the next call of the update function.

This function is not thread safe since it relies on an internal cache.

Parameters

| | | |
|-------|--------------------|---|
| [in] | <i>hSystem</i> | System module to work on. |
| [out] | <i>piNumIfaces</i> | Number of interfaces on this System module. |

Returns

| | |
|--------------------------|---|
| GC_ERR_SUCCESS | Operation was successful; no error occurred. |
| GC_ERR_NOT_INITIALIZED | No preceding call to GCInitLib . |
| GC_ERR_INVALID_HANDLE | Either the handle <i>hSystem</i> has an invalid value or the handle does not belong to a previously opened TL module through a call to TLOpen . |
| GC_ERR_INVALID_PARAMETER | Parameter <i>piNumInterfaces</i> is an invalid pointer (NULL or ~0x0). |

Error cases not covered in the list above may return error codes according to chapter 6.1.5 Error Handling on page 54.

6.3.2.6 TLOpen

| | | |
|----------|--------|---------------------------------|
| GC_ERROR | TLOpen | (TL_HANDLE * <i>phSystem</i>) |
|----------|--------|---------------------------------|

Opens the System module and puts the instance in the *phSystem* handle. This allocates all system wide resources. Call the [GCInitLib](#) function before this function. A System module can only be opened once.

Parameters

| | |
|-----------------------|--|
| [out] <i>phSystem</i> | System module handle of the newly opened system. It is recommended to initialize <i>*phSystem</i> to GENTL_INVALID_HANDLE before calling TLOpen to indicate an invalid handle. |
|-----------------------|--|

Returns

| | |
|--------------------------|---|
| GC_ERR_SUCCESS | Operation was successful; no error occurred. |
| GC_ERR_NOT_INITIALIZED | No preceding call to GCInitLib |
| GC_ERR_RESOURCE_IN_USE | The TL module has already been instantiated through a previous call to TLOpen . |
| GC_ERR_INVALID_PARAMETER | Parameter <i>phSystem</i> is an invalid pointer (NULL or ~0x0). |
| GC_ERR_ACCESS_DENIED | The access to the requested System module is denied. This may be because it is already opened by another Process but it might have other reasons as well. |

Error cases not covered in the list above may return error codes according to chapter 6.1.5 Error Handling on page 54.

6.3.2.7 TLOpenInterface

```
GC_ERROR TLOpenInterface ( TL_HANDLE      hSystem,
                           const char *    sIfaceID,
                           IF_HANDLE *    phIface )
```

Opens the given *sIfaceID* on the given *hSystem*.

Any subsequent call to `TLOpenInterface` with an *sIfaceID* which has already been opened will return an error `GC_ERR_RESOURCE_IN_USE`.

The interface ID need not match the one returned from [TLGetInterfaceID](#). As long as the GenTL Producer knows how to interpret that ID it will return a valid handle. For example, if in a specific implementation the interface has a user-defined name, this function will return a valid handle as long as the provided name refers to an internally known interface.

Parameters

- [in] *hSystem* System module to work on.
- [in] *sIfaceID* Unique interface ID to open as a 0-terminated C string.
- [out] *phIface* Interface handle of the newly created interface. It is recommended to initialize **phIface* to `GENTL_INVALID_HANDLE` before calling `TLOpenInterface` to indicate an invalid handle.

Returns

- `GC_ERR_SUCCESS` Operation was successful; no error occurred.
- `GC_ERR_NOT_INITIALIZED` No preceding call to [GCInitLib](#).
- `GC_ERR_RESOURCE_IN_USE` The Interface module has already been instantiated through a previous call to `TLOpenInterface`.
- `GC_ERR_INVALID_HANDLE` The handle *hSystem* is invalid (NULL) or does not reference an open System module retrieved through a call to [TLOpen](#).
- `GC_ERR_INVALID_ID` The GenTL Producer is unable to interpret the provided ID string *sIfaceID* or is not able to match it to an existing Interface.
- `GC_ERR_INVALID_PARAMETER` Parameters *phSystem* and/or *sIfaceID* are invalid pointers (NULL or ~0x0).
- `GC_ERR_ACCESS_DENIED` The access to the requested Interface is denied. This may be because it is already opened by another Process but it might have other reasons as well.

Error cases not covered in the list above may return error codes according to chapter 6.1.5 Error Handling on page 54.

6.3.2.8 TLUpdateInterfaceList

```
GC_ERROR TLUpdateInterfaceList ( TL_HANDLE      hSystem,
                                bool8_t *      pbChanged,
                                uint64_t       iTimeout )
```

Updates the internal list of available interfaces. This may change the connection between a list index and an interface ID. It is recommended to call `TLUpdateInterfaceList` after reconfiguration of the System module to reflect possible changes.

A call to this function has implications on the thread safety of

- [TLGetNumInterfaces](#)
- [TLGetInterfaceID](#)

Parameters

| | |
|------------------------|---|
| [in] <i>hSystem</i> | System module to work on. |
| [out] <i>pbChanged</i> | Contains <code>true</code> if the internal list was changed and <code>false</code> otherwise. If set to <code>NULL</code> nothing is written to this parameter. |
| [in] <i>iTimeout</i> | Timeout in ms. If set to <code>GENTL_INFINITE</code> the timeout is infinite and the function will only return after the operation is completed. In any case the GenTL Producer must make sure that this operation is completed in a reasonable amount of time depending on the underlying technology. Please be aware that there is no defined way of terminating such an update operation. On the other hand it is the GenTL Consumer's responsibility to call this function with a reasonable timeout. |

Returns

| | |
|---------------------------------------|---|
| <code>GC_ERR_SUCCESS</code> | Operation was successful; no error occurred. |
| <code>GC_ERR_NOT_INITIALIZED</code> | No preceding call to GCInitLib |
| <code>GC_ERR_INVALID_HANDLE</code> | The handle <i>hSystem</i> is invalid (<code>NULL</code>) or does not reference an open System module retrieved through a call to TLOpen . |
| <code>GC_ERR_INVALID_PARAMETER</code> | Parameter <i>pbChanged</i> is an invalid pointer (<code>NULL</code> or <code>~0x0</code>). |
| <code>GC_ERR_TIMEOUT</code> | The specified <i>iTimeout</i> expired before the Producer was able to completely update the list. In this case the "old" list stays valid. |

Error cases not covered in the list above may return error codes according to chapter 6.1.5 Error Handling on page 54.

6.3.3 Interface Functions

6.3.3.1 IFClose

```
GC_ERROR IFClose ( IF_HANDLE hIface )
```

Closes the Interface module associated with the given *hIface* handle. This closes all dependent Device modules and frees all interface related resources.

Parameters

[in] *hSystem* System module handle to close.

Returns

GC_ERR_SUCCESS Operation was successful; no error occurred.
 GC_ERR_NOT_INITIALIZED No preceding call to [GCInitLib](#).
 GC_ERR_INVALID_HANDLE The handle *hIface* is invalid (NULL) or does not reference an open Interface module retrieved through a call to [TLOpenInterface](#).

Error cases not covered in the list above may return error codes according to chapter 6.1.5 Error Handling on page 54.

6.3.3.2 IFGetInfo

```
GC_ERROR IFGetInfo ( IF_HANDLE hIface,
                    INTERFACE_INFO_CMD iInfoCmd,
                    INFO_DATATYPE * piType,
                    void * pBuffer,
                    size_t * piSize )
```

Inquire information about the Interface module as defined in `INTERFACE_INFO_CMD`.

Parameters

[in] *hIface* Interface module to work on.
 [in] *iInfoCmd* Information to be retrieved as defined in `INTERFACE_INFO_CMD`.
 [out] *piType* Data type of the *pBuffer* content as defined in the `INTERFACE_INFO_CMD` and `INFO_DATATYPE`.
 [in,out] *pBuffer* Pointer to a user allocated buffer to receive the requested information. If this parameter is NULL, *piSize* will contain the minimal size of *pBuffer* in bytes. If the *piType* is a string the size includes the terminating 0.
 [in,out] *piSize* *pBuffer* equal NULL:
 out: minimal size of *pBuffer* in bytes to hold all information

pBuffer unequal NULL:
in: size of the provided *pBuffer* in bytes
out: number of bytes filled by the function

Returns

- GC_ERR_SUCCESS Operation was successful; no error occurred.
- GC_ERR_NOT_INITIALIZED No preceding call to [GCInitLib](#)
- GC_ERR_INVALID_HANDLE The handle *hIface* is invalid (NULL) or does not reference an open Interface module retrieved through a call to [TLOpenInterface](#).
- GC_ERR_NOT_IMPLEMENTED Specified *iInfoCmd* is not implemented.
- GC_ERR_INVALID_PARAMETER Parameters *piSize* and/or *piType* are invalid pointers (NULL or ~0x0)
- GC_ERR_BUFFER_TOO_SMALL *pBuffer* is not NULL and the value of **piSize* is too small to receive the expected amount of data.
- GC_ERR_NOT_AVAILABLE The request is implemented but the requested information is currently not available for any reason.

Error cases not covered in the list above may return error codes according to chapter 6.1.5 Error Handling on page 54.

6.3.3.3 IFGetDeviceID

```
GC_ERROR IFGetDeviceID ( IF_HANDLE hIface,
                        uint32_t iIndex,
                        char * sDeviceID,
                        size_t * piSize )
```

Queries the unique ID of the device at *iIndex* in the internal device list. Prior to this call the [IFUpdateDeviceList](#) function must be called. The list content will not change until the next call of the update function.

This function is not thread safe since it relies on an internal cache.

Parameters

- [in] *hIface* Interface module to work on.
- [in] *iIndex* Zero-based index of the device on this interface.
- [in,out] *sDeviceID* Pointer to a user allocated C string buffer to receive the Device module ID at the given *iIndex*. If this parameter is NULL, *piSize* will contain the needed size of *sDeviceID* in bytes. The size includes the terminating 0.

[in,out] *piSize*

pBuffer equal NULL:

out: minimal size of *pBuffer* in bytes to hold all information

pBuffer unequal NULL:

in: size of the provided *pBuffer* in bytes

out: number of bytes filled by the function

Returns

GC_ERR_SUCCESS

Operation was successful; no error occurred.

GC_ERR_NOT_INITIALIZED

No preceding call to [GCInitLib](#).

GC_ERR_INVALID_HANDLE

The handle *hIface* is invalid (NULL) or does not reference an open Interface module retrieved through a call to [TLOpenInterface](#).

GC_ERR_INVALID_INDEX

iIndex is greater than the number of available Device modules - 1 retrieved through a call to [IFGetNumDevices](#).

GC_ERR_INVALID_PARAMETER

Parameter *piSize* is an invalid pointer (NULL or ~0x0).

GC_ERR_BUFFER_TOO_SMALL

sIfaceID is not NULL and the value of **piSize* is too small to receive the expected amount of data.

Error cases not covered in the list above may return error codes according to chapter 6.1.5 Error Handling on page 54.

6.3.3.4 IFGetDeviceInfo

```
GC_ERROR IFGetDeviceInfo ( IF_HANDLE      hIface,
                           const char *   sDeviceID,
                           DEVICE_INFO_CMD iInfoCmd,
                           INFO_DATATYPE * piType,
                           void *        pBuffer,
                           size_t *      piSize )
```

Inquire information about a device on the given Interface module *hIface* as defined in DEVICE_INFO_CMD without opening the device.

Parameters

[in] *hIface*

Interface module to work on.

[in] *sDeviceID*

Unique ID of the device to inquire information about.

[in] *iInfoCmd*

Information to be retrieved as defined in DEVICE_INFO_CMD.

[out] *piType*

Data type of the *pBuffer* content as defined in the DEVICE_INFO_CMD and INFO_DATATYPE.

[in,out] *pBuffer* Pointer to a user allocated buffer to receive the requested information. If this parameter is NULL, *piSize* will contain the minimal size of *pBuffer* in bytes. If the *piType* is a string the size includes the terminating 0.

[in,out] *piSize* *pBuffer* equal NULL:
 out: minimal size of *pBuffer* in bytes to hold all information
pBuffer unequal NULL:
 in: size of the provided *pBuffer* in bytes
 out: number of bytes filled by the function

Returns

GC_ERR_SUCCESS Operation was successful; no error occurred.

GC_ERR_NOT_INITIALIZED No preceding call to [GCInitLib](#).

GC_ERR_INVALID_HANDLE The handle *hIface* is invalid (NULL) or does not reference an open Interface module retrieved through a call to [TLOpenInterface](#).

GC_ERR_INVALID_ID The GenTL Producer is unable to interpret the provided ID string *sDeviceID* or is unable to match it to an existing Device.

GC_ERR_NOT_IMPLEMENTED Specified *iInfoCmd* is not implemented.

GC_ERR_INVALID_PARAMETER Parameters *piSize* and/or *piType* and/or *sDeviceID* are invalid pointers (NULL or ~0x0).

GC_ERR_BUFFER_TOO_SMALL *pBuffer* is not NULL and the value of **piSize* is too small to receive the expected amount of data.

GC_ERR_NOT_AVAILABLE The request is implemented but the requested information is currently not available for any reason.

Error cases not covered in the list above may return error codes according to chapter 6.1.5 Error Handling on page 54.

6.3.3.5 IFGetNumDevices

```
GC_ERROR IFGetNumDevices ( IF_HANDLE hIface,
                          uint32_t * piNumDevices )
```

Queries the number of available devices on this Interface module. Prior to this call the [IFUpdateDeviceList](#) function must be called. The list content will not change until the next call of the update function.

This function is not thread safe since it relies on an internal cache.

Parameters

[in] *hIface* Interface module to work on.
 [out] *piNumDevices* Number of devices on this Interface module.

Returns

GC_ERR_SUCCESS Operation was successful; no error occurred.
 GC_ERR_NOT_INITIALIZED No preceding call to [GCInitLib](#)
 GC_ERR_INVALID_HANDLE The handle *hIface* is invalid (NULL) or does not reference an open Interface module retrieved through a call to [TLOpenInterface](#).
 GC_ERR_INVALID_PARAMETER Parameter *piNumDevices* is an invalid pointer (NULL or ~0x0).

Error cases not covered in the list above may return error codes according to chapter 6.1.5 Error Handling on page 54.

6.3.3.6 IFOpenDevice

```
GC_ERROR IFOpenDevice ( IF_HANDLE hIface,
                        const char * sDeviceID,
                        DEVICE_ACCESS_FLAGS iOpenFlags,
                        DEV_HANDLE * phDevice )
```

Opens the given *sDeviceID* with the given *iOpenFlags* on the given *hIface*.

Any subsequent call to [IFOpenDevice](#) with an *sDeviceID* which has already been opened will return an error GC_ERR_RESOURCE_IN_USE.

The device ID need not match the one returned from [IFGetDeviceID](#). As long as the GenTL Producer knows how to interpret that ID it will return a valid handle. For example, if in a specific implementation the device has a user-defined name, this function will return a valid handle as long as the provided name refers to an internally known device.

Parameters

[in] *hIface* Interface module to work on.
 [in] *sDeviceID* Unique device ID to open as a 0-terminated C string.
 [in] *iOpenFlags* Configures the open process as defined in the DEVICE_ACCESS_FLAGS.
 [out] *phDevice* Device handle of the newly created Device module. It is recommended to initialize **phDevice* to GENTL_INVALID_HANDLE before calling [IFOpenDevice](#) to indicate an invalid handle.

Returns

GC_ERR_SUCCESS Operation was successful; no error occurred.

| | |
|--------------------------|--|
| GC_ERR_NOT_INITIALIZED | No preceding call to GCInitLib . |
| GC_ERR_INVALID_HANDLE | The handle <i>hIface</i> is invalid (NULL) or does not reference an open Interface module retrieved through a call to TLOpenInterface . |
| GC_ERR_INVALID_ID | The GenTL Producer is unable to interpret the provided ID string <i>sDeviceID</i> or is not able to match it to an existing Device. |
| GC_ERR_RESOURCE_IN_USE | The Device module has already been instantiated through a previous call to IFOpenDevice . |
| GC_ERR_INVALID_PARAMETER | Parameters <i>sDeviceID</i> and/or <i>phDevice</i> are invalid pointers (NULL or ~0x0) or <i>iOpenFlags</i> contains a non valid/unknown combination of flags. |
| GC_ERR_NOT_IMPLEMENTED | <i>iOpenFlags</i> contains flags which are not implemented by this GenTL Producer. |
| GC_ERR_ACCESS_DENIED | The access to the requested device is denied. |

Error cases not covered in the list above may return error codes according to chapter 6.1.5 Error Handling on page 54.

6.3.3.7 IFUpdateDeviceList

```
GC_ERROR IFUpdateDeviceList ( IF_HANDLE      hIface,
                             bool8_t *      pbChanged,
                             uint64_t      iTimeout )
```

Updates the internal list of available devices. This may change the connection between a list index and a device ID. It is recommended to call `IFUpdateDeviceList` regularly from time to time and after reconfiguration of the Interface module to reflect possible changes.

A call to this function has implications on the thread safety of

- [IFGetNumDevices](#)
- [IFGetDeviceID](#)

Parameters

| | | |
|-------|------------------|---|
| [in] | <i>hIface</i> | Interface module to work on. |
| [out] | <i>pbChanged</i> | Contains <code>true</code> if the internal list was changed and <code>false</code> otherwise. If set to NULL nothing is written to this parameter. |
| [in] | <i>iTimeout</i> | Timeout in ms. If set to <code>GENTL_INFINITE</code> the timeout is infinite and the function will only return if the operation is completed. In any case the GenTL Producer must make sure |

that this operation is completed in a reasonable amount of time depending on the underlying technology. Please be aware that there is no defined way of terminating such an update operation. On the other hand it is the GenTL Consumer’s responsibility to call this function with a reasonable timeout.

Returns

- GC_ERR_SUCCESS Operation was successful; no error occurred.
- GC_ERR_NOT_INITIALIZED No preceding call to [GCInitLib](#).
- GC_ERR_INVALID_HANDLE The handle *hIface* is invalid (NULL) or does not reference an open Interface module retrieved through a call to [TLOpenInterface](#).
- GC_ERR_INVALID_PARAMETER Parameter *pbChanged* is an invalid pointer (NULL or ~0x0).
- GC_ERR_TIMEOUT The specified *iTimeout* expired before the Producer was able to completely update the list. In this case the “old” list stays valid.

Error cases not covered in the list above may return error codes according to chapter 6.1.5 Error Handling on page 54.

6.3.3.8 IFGetParentTL

```
GC_ERROR IFGetParentTL ( IF_HANDLE hIface,
                        TL_HANDLE * phSystem )
```

Retrieve a handle to the parent TL module.

Parameters

- [in] *hIface* Interface module to work on.
- [out] *phSystem* Handle to the parent System module

Returns

- GC_ERR_SUCCESS Operation was successful; no error occurred.
- GC_ERR_NOT_INITIALIZED No preceding call to [GCInitLib](#)
- GC_ERR_INVALID_HANDLE The handle *hIface* is invalid (NULL) or does not reference an open Interface module retrieved through a call to [TLOpenInterface](#).
- GC_ERR_INVALID_PARAMETER Parameter *phSystem* is an invalid pointer (NULL or ~0x0).

Error cases not covered in the list above may return error codes according to chapter 6.1.5 Error Handling on page 54.

6.3.4 Device Functions

6.3.4.1 DevClose

| | | | |
|----------|----------|--------------|------------------|
| GC_ERROR | DevClose | (DEV_HANDLE | <i>hDevice</i>) |
|----------|----------|--------------|------------------|

Closes the Device module associated with the given *hDevice* handle. This frees all resources of the Device module and closes all dependent Data Stream module instances. If DevClose is called with a handle returned from a call to [DevGetPort](#) a GC_ERR_INVALID_HANDLE is to be returned.

Parameters

[in] *hDevice* Device module handle to close.

Returns

| | |
|------------------------|---|
| GC_ERR_SUCCESS | Operation was successful; no error occurred. |
| GC_ERR_NOT_INITIALIZED | No preceding call to GCInitLib . |
| GC_ERR_INVALID_HANDLE | The handle <i>hDevice</i> is invalid (NULL) or does not reference an open Interface module retrieved through a call to IFOpenDevice . |

Error cases not covered in the list above may return error codes according to chapter 6.1.5 Error Handling on page 54.

6.3.4.2 DevGetInfo

| | | | |
|----------|------------|-----------------|-------------------|
| GC_ERROR | DevGetInfo | (DEV_HANDLE | <i>hDevice</i> , |
| | | DEVICE_INFO_CMD | <i>iInfoCmd</i> , |
| | | INFO_DATATYPE * | <i>piType</i> , |
| | | void * | <i>pBuffer</i> , |
| | | size_t * | <i>piSize</i>) |

Inquire information about the Device module as defined in DEVICE_INFO_CMD.

Parameters

| | | |
|-------|-----------------|--|
| [in] | <i>hDevice</i> | Device module to work on. |
| [in] | <i>iInfoCmd</i> | Information to be retrieved as defined in DEVICE_INFO_CMD. |
| [out] | <i>piType</i> | Data type of the <i>pBuffer</i> content as defined in the DEVICE_INFO_CMD and INFO_DATATYPE. |

[in,out] *pBuffer* Pointer to a user allocated buffer to receive the requested information. If this parameter is NULL, *piSize* will contain the minimal size of *pBuffer* in bytes. If the *piType* is a string the size includes the terminating 0.

[in,out] *piSize* *pBuffer* equal NULL:
 out: minimal size of *pBuffer* in bytes to hold all information
pBuffer unequal NULL:
 in: size of the provided *pBuffer* in bytes
 out: number of bytes filled by the function

Returns

GC_ERR_SUCCESS Operation was successful; no error occurred.

GC_ERR_NOT_INITIALIZED No preceding call to [GCInitLib](#).

GC_ERR_INVALID_HANDLE The handle *hDevice* is invalid (NULL) or does not reference an open Device module retrieved through a call to [IFOpenDevice](#).

GC_ERR_NOT_IMPLEMENTED Specified *iInfoCmd* is not implemented.

GC_ERR_INVALID_PARAMETER Parameters *piSize* and/or *piType* are invalid pointers (NULL or ~0x0).

GC_ERR_BUFFER_TOO_SMALL *pBuffer* is not NULL and the value of **piSize* is too small to receive the expected amount of data.

GC_ERR_NOT_AVAILABLE The request is implemented but the requested information is currently not available for any reason.

Error cases not covered in the list above may return error codes according to chapter 6.1.5 Error Handling on page 54.

6.3.4.3 DevGetDataStreamID

```
GC_ERROR DevGetDataStreamID ( DEV_HANDLE    hDevice,
                             uint32_t      iIndex,
                             char *        sDataStreamID,
                             size_t *      piSize )
```

Queries the unique ID of the data stream at *iIndex* in the internal data stream list.

For GenTL Producers which do not provide a data stream the number of available data streams is zero. Calls to [DevGetDataStreamID](#) or [DevOpenDataStream](#) will fail. Nevertheless a GenTL Producer must export all functions of the public interface

Parameters

[in] *hDevice* Device module to work on.

[in] *iIndex* Zero-based index of the data stream on this device.
 [in,out] *sDataStreamID* Pointer to a user allocated C string buffer to receive the Interface module ID at the given *iIndex*. If this parameter is NULL, *piSize* will contain the needed size of *sDataStreamID* in bytes. The size includes the terminating 0.
 [in,out] *piSize* *pBuffer* equal NULL:
 out: minimal size of *pBuffer* in bytes to hold all information
pBuffer unequal NULL:
 in: size of the provided *pBuffer* in bytes
 out: number of bytes filled by the function

Returns

GC_ERR_SUCCESS Operation was successful; no error occurred.
 GC_ERR_NOT_INITIALIZED No preceding call to [GCInitLib](#).
 GC_ERR_INVALID_HANDLE The handle *hDevice* is invalid (NULL) or does not reference an open Device module retrieved through a call to [IFOpenDevice](#).
 GC_ERR_NOT_IMPLEMENTED The Producer does not implement streaming or the remote device does not provide a stream. [DevGetNumDataStreams](#) reports zero.
 GC_ERR_RESOURCE_IN_USE The stream has already been opened in this process.
 GC_ERR_INVALID_INDEX *iIndex* is greater than the number of available Data Stream modules - 1 retrieved through a call to [DevGetNumDataStreams](#).
 GC_ERR_INVALID_PARAMETER Parameter *piSize* is an invalid pointer (NULL or ~0x0).
 GC_ERR_BUFFER_TOO_SMALL *sIfaceID* is not NULL and the value of **piSize* is too small to receive the expected amount of data.

Error cases not covered in the list above may return error codes according to chapter 6.1.5 Error Handling on page 54.

6.3.4.4 DevGetNumDataStreams

```
GC_ERROR DevGetNumDataStreams( DEV_HANDLE hDevice,
                               uint32_t * piNumDataStreams)
```

Queries the number of available data streams on this Device module.

For GenTL Producers which do not provide a data stream the number of available data streams is zero. Calls to [DevGetDataStreamID](#) or [DevOpenDataStream](#) will fail with GC_ERR_NOT_IMPLEMENTED. Nevertheless a GenTL Producer must export all functions of the public interface

| | | |
|------------------------|----------------|---|
| GEN<i>CAM | |  |
| Version 1.4 | GenTL Standard | |

Parameters

[in] *hDevice* Device module to work on.
[out] *piNumDataStreams* Number of data stream on this Device module.

Returns

GC_ERR_SUCCESS Operation was successful; no error occurred.
GC_ERR_NOT_INITIALIZED No preceding call to [GCInitLib](#)
GC_ERR_INVALID_HANDLE The handle *hDevice* is invalid (NULL) or does not reference an open Device module retrieved through a call to [IFOpenDevice](#).
GC_ERR_INVALID_PARAMETER Parameter *piNumDataStreams* is an invalid pointer (NULL or ~0x0).

Error cases not covered in the list above may return error codes according to chapter 6.1.5 Error Handling on page 54.

6.3.4.5 DevGetPort

| | | | | |
|----------|------------|---|---------------|----------------------|
| GC_ERROR | DevGetPort | (| DEV_HANDLE | <i>hDevice,</i> |
| | | | PORT_HANDLE * | <i>phRemoteDev</i>) |

Retrieves the port handle for the associated remote device.

This function does not return the handle for the Port functions for the Device module but for the physical remote device.

The *phRemoteDev* handle must not be closed explicitly. This is done automatically when [DevClose](#) is called on this Device module.

The remote device Port handle is no valid source for Events. Therefore it must not be used to register Events through [GCRegisterEvent](#).

Parameters

[in] *hDevice* Device module to work on.
[out] *phRemoteDev* Port handle for the remote device. It is recommended to initialize **phRemoteDev* to GENTL_INVALID_HANDLE before calling [DevGetPort](#) to indicate an invalid handle.

Returns

GC_ERR_SUCCESS Operation was successful; no error occurred.
GC_ERR_NOT_INITIALIZED No preceding call to [GCInitLib](#).
GC_ERR_INVALID_HANDLE The handle *hDevice* is invalid (NULL) or does not reference an open Device module retrieved through a call to [IFOpenDevice](#).

GC_ERR_INVALID_PARAMETER Parameter *phRemoteDev* is an invalid pointer (NULL or ~0x0).

Error cases not covered in the list above may return error codes according to chapter 6.1.5 Error Handling on page 54.

6.3.4.6 DevOpenDataStream

```
GC_ERROR DevOpenDataStream ( DEV_HANDLE hDevice,
                             const char * sDataStreamID,
                             DS_HANDLE * phDataStream )
```

Opens the given *sDataStreamID* on the given *hDevice*.

Any subsequent call to [DevOpenDataStream](#) with an *sDataStreamID* which has already been opened will return an error GC_ERR_RESOURCE_IN_USE.

The Data Stream ID need not match the one returned from [DevGetDataStreamID](#). As long as the GenTL Producer knows how to interpret that ID it will return a valid handle. For example, if in a specific implementation the data stream has a user defined name, this function will return a valid handle as long as the provided name refers to an internally known data stream.

For GenTL Producers which do not provide a data stream the number of available data streams is zero. Calls to [DevGetDataStreamID](#) or [DevOpenDataStream](#) will fail. Nevertheless a GenTL Producer must export all functions of the public interface

Parameters

| | | |
|-------|----------------------|---|
| [in] | <i>hDevice</i> | Device module to work on |
| [in] | <i>sDataStreamID</i> | Unique data stream ID to open as a 0-terminated C string. |
| [out] | <i>phDataStream</i> | Data Stream module handle of the newly created stream. It is recommended to initialize <i>*phDataStream</i> to GENTL_INVALID_HANDLE before calling DevOpenDataStream to indicate an invalid handle. |

Returns

| | |
|------------------------|--|
| GC_ERR_SUCCESS | Operation was successful; no error occurred. |
| GC_ERR_NOT_INITIALIZED | No preceding call to GCInitLib . |
| GC_ERR_INVALID_HANDLE | The handle <i>hDevice</i> is invalid (NULL) or does not reference an open Device module retrieved through a call to IFOpenDevice . |
| GC_ERR_RESOURCE_IN_USE | The Data Stream module has already been instantiated through a previous call to DevOpenDataStream . |

| | |
|--------------------------|--|
| GC_ERR_INVALID_ID | The GenTL Producer is unable to interpret the provided ID string <i>sDataStreamID</i> or is not able to match it to an existing Data Stream. |
| GC_ERR_INVALID_PARAMETER | Parameters <i>phDataStream</i> and/or <i>sDataStream</i> are invalid pointers (NULL or ~0x0). |
| GC_ERR_ACCESS_DENIED | The access to the requested Data Stream module is denied. This may be because it is already opened by another Process but it might have other reasons as well. |
| GC_ERR_NOT_AVAILABLE | The <i>sDataStreamID</i> of the stream is generally valid but the stream is not available. |

Error cases not covered in the list above may return error codes according to chapter 6.1.5 Error Handling on page 54.

6.3.4.7 DevGetParentIF

```
GC_ERROR DevGetParentIF ( DEV_HANDLE hDevice,
                        IF_HANDLE * phIface )
```

Retrieve a handle to the parent Interface module.

Parameters

| | |
|----------------------|---|
| [in] <i>hDevice</i> | Device module to work on. |
| [out] <i>phIface</i> | Handle to the parent Interface module . |

Returns

| | |
|--------------------------|--|
| GC_ERR_SUCCESS | Operation was successful; no error occurred. |
| GC_ERR_NOT_INITIALIZED | No preceding call to GCInitLib . |
| GC_ERR_INVALID_HANDLE | The handle <i>hDevice</i> is invalid (NULL) or does not reference an open Device module retrieved through a call to IFOpenDevice . |
| GC_ERR_INVALID_PARAMETER | Parameter <i>phIface</i> is an invalid pointer (NULL or ~0x0). |

Error cases not covered in the list above may return error codes according to chapter 6.1.5 Error Handling on page 54.

6.3.5 Data Stream Functions

6.3.5.1 DSAllocAndAnnounce

```
GC_ERROR DSAllocAndAnnounceBuffer ( DS_HANDLE hDataStream,
                                     size_t      iBufferSize,
                                     void *      pPrivate,
                                     BUFFER_HANDLE * phBuffer )
```

This function allocates the memory for a single buffer and announces this buffer to the Data Stream associated with the *hDataStream* handle and returns a *hBuffer* handle which references that single buffer until the buffer is revoked. This will allocate internal resources which will be freed upon a call to [DSRevokeBuffer](#).

Announcing a buffer to a data stream does not mean that this buffer will be automatically queued for acquisition. This is done through a separate call to [DSQueueBuffer](#).

The memory referenced in this buffer must stay valid until a buffer is revoked with [DSRevokeBuffer](#).

Every call of this function should be matched with a call of [DSRevokeBuffer](#) even though the resources are also freed when the module is closed.

Refer to chapter 5.2.1 in order to determine the right buffer size.

Parameters

| | | |
|-------|--------------------|---|
| [in] | <i>hDataStream</i> | Data Stream module to work on. |
| [in] | <i>iBufferSize</i> | Size of the buffer in bytes. |
| [in] | <i>pPrivate</i> | Pointer to private data which will be passed to the GenTL Consumer on New Buffer events. This parameter may be NULL. |
| [out] | <i>phBuffer</i> | Buffer module handle of the newly announced buffer. It is recommended to initialize <i>*phBuffer</i> to GENTL_INVALID_HANDLE before calling DSAllocAndAnnounceBuffer to indicate an invalid handle. |

Returns

| | |
|--------------------------|--|
| GC_ERR_SUCCESS | Operation was successful; no error occurred. |
| GC_ERR_NOT_INITIALIZED | No preceding call to GCInitLib |
| GC_ERR_INVALID_HANDLE | The handle <i>hDataStream</i> is invalid (NULL) or does not reference an open Data Stream module retrieved through a call to DevOpenDataStream . |
| GC_ERR_INVALID_PARAMETER | Parameter <i>phBuffer</i> is an invalid pointer (NULL or ~0x0). |

Error cases not covered in the list above may return error codes according to chapter 6.1.5 Error Handling on page 54.

6.3.5.2 DSAnnounceBuffer

```
GC_ERROR DSAnnounceBuffer ( DS_HANDLE hDataStream,
                             void * pBuffer,
                             size_t iSize,
                             void * pPrivate,
                             BUFFER_HANDLE * phBuffer)
```

This announces a GenTL Consumer allocated memory to the Data Stream associated with the *hDataStream* handle and returns a *hBuffer* handle which references that single buffer until the buffer is revoked. This will allocate internal resources which will be freed upon a call to [DSRevokeBuffer](#).

Announcing a buffer to a data stream does not mean that this buffer will be automatically queued for acquisition. This is done through a separate call to [DSQueueBuffer](#).

The memory referenced in *pBuffer* must stay valid until the buffer is revoked with [DSRevokeBuffer](#). Every call of this function must be matched with a call of [DSRevokeBuffer](#).

A buffer can only be announced once to a given stream. If a GenTL Consumer tries to announce an already announced buffer the function will return the error GC_ERR_RESOURCE_IN_USE. A buffer may additionally be announced to one or more other data stream(s) which will then result in one or more additional handles. The Consumer needs to take care about synchronisation between these streams.

Refer to chapter 5.2.1 in order to determine the right buffer size.

Parameters

| | | |
|-------|--------------------|---|
| [in] | <i>hDataStream</i> | Data Stream module to work on. |
| [in] | <i>pBuffer</i> | Pointer to buffer memory to announce. |
| [in] | <i>iSize</i> | Size of the <i>pBuffer</i> in bytes. |
| [in] | <i>pPrivate</i> | Pointer to private data which will be passed to the GenTL Consumer on New Buffer events. |
| [out] | <i>phBuffer</i> | Buffer module handle of the newly announced buffer. It is recommended to initialize <i>*phBuffer</i> to GENTL_INVALID_HANDLE before calling DSAnnounceBuffer to indicate an invalid handle. |

Returns

| | |
|------------------------|--|
| GC_ERR_SUCCESS | Operation was successful; no error occurred. |
| GC_ERR_NOT_INITIALIZED | No preceding call to GCInitLib |

| | |
|--------------------------|--|
| GC_ERR_INVALID_HANDLE | The handle <i>hDataStream</i> is invalid (NULL) or does not reference an open Data Stream module retrieved through a call to DevOpenDataStream . |
| GC_ERR_INVALID_PARAMETER | Parameters <i>pBuffer</i> and/or <i>phBuffer</i> are invalid pointers (NULL or ~0x0). |
| GC_ERR_RESOURCE_IN_USE | The specified <i>pBuffer</i> is already announced to this Data Stream module or, depending on the implementation of the GenTL Producer, it has already been announced to another instance of the Data Stream module (see chapter 3.6). |

Error cases not covered in the list above may return error codes according to chapter 6.1.5 Error Handling on page 54.

6.3.5.3 DSClose

| | |
|------------------|----------------------------------|
| GC_ERROR DSClose | (DS_HANDLE <i>hDataStream</i>) |
|------------------|----------------------------------|

Closes the Data Stream module associated with the given *hDataStream* handle. This frees all resources of the Data Stream module, discards and revokes all buffers.

Parameters

[in] *hDataStream* Data Stream module handle to close.

Returns

| | |
|------------------------|--|
| GC_ERR_SUCCESS | Operation was successful; no error occurred. |
| GC_ERR_NOT_INITIALIZED | No preceding call to GCInitLib . |
| GC_ERR_INVALID_HANDLE | The handle <i>hDataStream</i> is invalid (NULL) or does not reference an open Data Stream module retrieved through a call to DevOpenDataStream . |

Error cases not covered in the list above may return error codes according to chapter 6.1.5 Error Handling on page 54.

6.3.5.4 DSFlushQueue

| | |
|-----------------------|--|
| GC_ERROR DSFlushQueue | (DS_HANDLE <i>hDataStream</i> , ACQ_QUEUE_TYPE <i>iOperation</i>) |
|-----------------------|--|

Flushes the by *iOperation* defined internal buffer pool or queue to another one as defined in ACQ_QUEUE_TYPE.

Parameters

- [in] *hDataStream* Data Stream module to work on.
- [in] *iOperation* Flush operation to perform as defined in ACQ_QUEUE_TYPE.

Returns

- GC_ERR_SUCCESS Operation was successful; no error occurred.
- GC_ERR_NOT_INITIALIZED No preceding call to [GCInitLib](#).
- GC_ERR_INVALID_HANDLE The handle *hDataStream* is invalid (NULL) or does not reference an open Data Stream module retrieved through a call to [DevOpenDataStream](#).
- GC_ERR_NOT_IMPLEMENTED *iOperation* is not implemented.

Error cases not covered in the list above may return error codes according to chapter 6.1.5 Error Handling on page 54.

6.3.5.5 DSGetBufferID

```
GC_ERROR DSGetBufferID ( DS_HANDLE hDataStream,
                        uint32_t iIndex,
                        BUFFER_HANDLE * phBuffer )
```

Queries the buffer handle for a given *iIndex*. The buffer handle works as a unique ID of the Buffer module.

Note that the relation between index and buffer handle might change with additional announced and/or revoked buffers. As long as no buffers are announced or revoked this relation must not change.

The number of announced buffers can be queried with the [DSGetInfo](#) function.

Parameters

- [in] *hDataStream* Data Stream module to work on.
- [in] *iIndex* Zero-based index of the buffer on this data stream.
- [in,out] *phBuffer* Buffer module handle of the given *iIndex*.

Returns

- GC_ERR_SUCCESS Operation was successful; no error occurred.
- GC_ERR_NOT_INITIALIZED No preceding call to [GCInitLib](#).
- GC_ERR_INVALID_HANDLE The handle *hDataStream* is invalid (NULL) or does not reference an open Data Stream module retrieved through a call to [DevOpenDataStream](#).

- GC_ERR_INVALID_INDEX *iIndex* is greater than the number of announced buffers through calls to [DSAllocAndAnnounce](#) or DSAnnounceBuffer.
- GC_ERR_INVALID_PARAMETER Parameter *phBuffer* is an invalid pointer (NULL or ~0x0).

Error cases not covered in the list above may return error codes according to chapter 6.1.5 Error Handling on page 54.

6.3.5.6 DSGetBufferInfo

```
GC_ERROR DSGetBufferInfo ( DS_HANDLE hDataStream,
                          BUFFER_HANDLE hBuffer,
                          BUFFER_INFO_CMD iInfoCmd,
                          INFO_DATATYPE * piType,
                          void * pBuffer,
                          size_t * piSize )
```

Inquire information about the Buffer module associated with *hBuffer* on the *hDataStream* instance as defined in BUFFER_INFO_CMD.

In case the GenTL Producer needs to combine multiple informations into a structure in order to reduce the number of calls from the GenTL Consumer to the GenTL Producer this structure is then queried through a custom BUFFER_INFO_CMD id. The layout of that struct has to be documented with the GenTL Producer. In case the GenTL Producer implements such optimization it should nevertheless implement the standard inquiry commands.

Parameters

- [in] *hDataStream* Data Stream module to work on.
- [in] *hBuffer* Buffer handle to retrieve information about.
- [in] *iInfoCmd* Information to be retrieved as defined in BUFFER_INFO_CMD.
- [out] *piType* Data type of the *pBuffer* content as defined in the BUFFER_INFO_CMD and INFO_DATATYPE.
- [in,out] *pBuffer* Pointer to a user allocated buffer to receive the requested information. If this parameter is NULL, *piSize* will contain the minimal size of *pBuffer* in bytes. If the *piType* is a string the size includes the terminating 0.
- [in,out] *piSize* *pBuffer* equal NULL:
out: minimal size of *pBuffer* in bytes to hold all information
pBuffer unequal NULL:
in: size of the provided *pBuffer* in bytes
out: number of bytes filled by the function

Returns

| | |
|--------------------------|---|
| GC_ERR_SUCCESS | Operation was successful; no error occurred. |
| GC_ERR_NOT_INITIALIZED | No preceding call to GCInitLib |
| GC_ERR_INVALID_HANDLE | The handle <i>hDataStream</i> is invalid (NULL) or does not reference an open Data Stream module retrieved through a call to DevOpenDataStream or the handle <i>hBuffer</i> is invalid (NULL) or does not reference an announced Buffer module retrieved through a call to DSAllocAndAnnounce or DSAnnounceBuffer . |
| GC_ERR_NOT_IMPLEMENTED | Specified <i>iInfoCmd</i> is not implemented. |
| GC_ERR_INVALID_PARAMETER | Parameters <i>piSize</i> and/or <i>piType</i> are invalid pointers (NULL or ~0x0) |
| GC_ERR_BUFFER_TOO_SMALL | <i>pBuffer</i> is not NULL and the value of <i>*piSize</i> is too small to receive the expected amount of data. |
| GC_ERR_NOT_AVAILABLE | The request is implemented but the requested information is currently not available for any reason. |

Error cases not covered in the list above may return error codes according to chapter 6.1.5 Error Handling on page 54.

6.3.5.7 DSGetInfo

```
GC_ERROR DSGetInfo ( DS_HANDLE hDataStream,
                     STREAM_INFO_CMD iInfoCmd,
                     INFO_DATATYPE * piType,
                     void * pBuffer,
                     size_t * piSize )
```

Inquire information about the Data Stream module associated with *hDataStream* as defined in `STREAM_INFO_CMD`.

Parameters

| | | |
|----------|--------------------|---|
| [in] | <i>hDataStream</i> | Data Stream module to work on. |
| [in] | <i>iInfoCmd</i> | Information to be retrieved as defined in <code>STREAM_INFO_CMD</code> . |
| [out] | <i>piType</i> | Data type of the <i>pBuffer</i> content as defined in the <code>STREAM_INFO_CMD</code> and <code>INFO_DATATYPE</code> . |
| [in,out] | <i>pBuffer</i> | Pointer to a user allocated buffer to receive the requested information. If this parameter is NULL, <i>piSize</i> will contain the minimal size of <i>pBuffer</i> in bytes. If the <i>piType</i> is a string the size includes the terminating 0. |
| [in,out] | <i>piSize</i> | <i>pBuffer</i> equal NULL: out: minimal size of <i>pBuffer</i> in bytes to hold all information |

pBuffer unequal NULL:
 in: size of the provided *pBuffer* in bytes
 out: number of bytes filled by the function

Returns

- GC_ERR_SUCCESS Operation was successful; no error occurred.
- GC_ERR_NOT_INITIALIZED No preceding call to [GCInitLib](#)
- GC_ERR_INVALID_HANDLE The handle *hDataStream* is invalid (NULL) or does not reference an open Data Stream module retrieved through a call to [DevOpenDataStream](#).
- GC_ERR_NOT_IMPLEMENTED Specified *iInfoCmd* is not implemented.
- GC_ERR_INVALID_PARAMETER Parameters *piSize* and/or *piType* are invalid pointers (NULL or ~0x0)
- GC_ERR_BUFFER_TOO_SMALL *pBuffer* is not NULL and the value of **piSize* is too small to receive the expected amount of data.
- GC_ERR_NOT_AVAILABLE The request is implemented but the requested information is currently not available for any reason.

Error cases not covered in the list above may return error codes according to chapter 6.1.5 Error Handling on page 54.

6.3.5.8 DSQueueBuffer

```
GC_ERROR DSQueueBuffer ( DS_HANDLE hDataStream,
                        BUFFER_HANDLE hBuffer )
```

This function queues a particular buffer for acquisition. A buffer can be queued for acquisition any time after the buffer was announced (before or after the acquisition has been started) when it is not currently queued. Furthermore, a buffer which is already waiting to be delivered cannot be queued for acquisition. A queued buffer cannot be revoked.

The order of the delivered buffers is not necessarily the same as the order in which they have been queued.

Parameters

- [in] *hDataStream* Data Stream module to work on.
- [in] *hBuffer* Buffer handle to queue.

Returns

- GC_ERR_SUCCESS Operation was successful; no error occurred.
- GC_ERR_NOT_INITIALIZED No preceding call to [GCInitLib](#)

GC_ERR_INVALID_HANDLE The handle *hDataStream* is invalid (NULL) or does not reference an open Data Stream module retrieved through a call to [DevOpenDataStream](#) or *hBuffer* is invalid (NULL) or does not reference an announced Buffer.

Error cases not covered in the list above may return error codes according to chapter 6.1.5 Error Handling on page 54.

6.3.5.9 DSRevokeBuffer

```
GC_ERROR DSRevokeBuffer ( DS_HANDLE hDataStream,
                          BUFFER_HANDLE hBuffer,
                          void ** ppBuffer,
                          void ** ppPrivate )
```

Removes an announced buffer from the acquisition engine. This function will free all internally allocated resources associated with this buffer. A buffer can only be revoked if it is not queued in any queue. A buffer is automatically revoked when the stream is closed.

Parameters

- [in] *hDataStream* Data Stream module to work on.
- [in] *hBuffer* Buffer handle to revoke.
- [out] *ppBuffer* Pointer to the buffer memory. This is for convenience if GenTL Consumer allocated memory is used which is to be freed. If the buffer was allocated by the GenTL Producer NULL is to be returned. If the parameter is set to NULL it is ignored
- [out] *ppPrivate* Pointer to the user data pointer given in the announce function. If the parameter is set to NULL it is ignored

Returns

- GC_ERR_SUCCESS Operation was successful; no error occurred.
- GC_ERR_NOT_INITIALIZED No preceding call to [GCInitLib](#)
- GC_ERR_INVALID_HANDLE The handle *hDataStream* is invalid (NULL) or does not reference an open Data Stream module retrieved through a call to [DevOpenDataStream](#) or *hBuffer* is invalid (NULL) or does not reference an announced Buffer.

Error cases not covered in the list above may return error codes according to chapter 6.1.5 Error Handling on page 54.

6.3.5.10 DSStartAcquisition

```
GC_ERROR DSStartAcquisition ( DS_HANDLE          hDataStream,
                               ACQ_START_FLAGS iStartFlags,
                               uint64_t        iNumToAcquire )
```

Starts the acquisition engine on the host. Each call to [DSStartAcquisition](#) must be accompanied by a call to [DSStopAcquisition](#).

Parameters

- [in] *hDataStream* Data Stream module to work on.
- [in] *iStartFlags* As defined in ACQ_START_FLAGS.
- [in] *iNumToAcquire* Sets the number of filled/delivered buffers after which the acquisition engine stops automatically. Buffers which are internally discarded or missed are not counted. If set to GENTL_INFINITE the acquisition continues until a call to [DSStopAcquisition](#) is issued. If set to 0 a GC_ERR_INVALID_PARAMETER is returned.

Returns

- GC_ERR_SUCCESS Operation was successful; no error occurred.
- GC_ERR_NOT_INITIALIZED No preceding call to [GCInitLib](#)
- GC_ERR_INVALID_HANDLE The handle *hDataStream* is invalid (NULL) or does not reference an open Data Stream module retrieved through a call to [DevOpenDataStream](#).
- GC_ERR_NOT_IMPLEMENTED One or more flags set in *iStartFlags* referencing functionality which is not implemented.
- GC_ERR_INVALID_PARAMETER *iNumToAcquire* is 0.
- GC_ERR_INVALID_BUFFER Not enough buffers have been announced to start the acquisition in the currently active acquisition mode.
- GC_ERR_RESOURCE_IN_USE The Acquisition is already active.
- GC_ERR_BUFFER_TOO_SMALL One or more of the announced buffers are smaller than the expected payload requires. This is optional to the GenTL Producer implementation if it chooses to not start acquisition in this case or if the acquisition is started and the buffers are not or only partially filled. (see chapter 5.2.1).

Error cases not covered in the list above may return error codes according to chapter 6.1.5 Error Handling on page 54.

6.3.5.11 DSStopAcquisition

```
GC_ERROR DSStopAcquisition ( DS_HANDLE      hDataStream,
                             ACQ_STOP_FLAGS iStopFlags )
```

Stops the acquisition engine on the host. There must be a call to [DSStopAcquisition](#) accompanying each call to [DSStartAcquisition](#) even though the stream already stopped because the number of frames to acquire was reached. This is also independent of the acquisition modes.

Parameters

[in] *hDataStream* Data Stream module to work on.
 [in] *iStopFlags* Stops the acquisition as defined in ACQ_STOP_FLAGS.

Returns

GC_ERR_SUCCESS Operation was successful; no error occurred.
 GC_ERR_NOT_INITIALIZED No preceding call to [GCInitLib](#)
 GC_ERR_INVALID_HANDLE The handle *hDataStream* is invalid (NULL) or does not reference an open Data Stream module retrieved through a call to [DevOpenDataStream](#).
 GC_ERR_NOT_IMPLEMENTED One or more flags set in *iStopFlags* referencing functionality which is not implemented.
 GC_ERR_RESOURCE_IN_USE The Acquisition has already been terminated or it has not been started.

Error cases not covered in the list above may return error codes according to chapter 6.1.5 Error Handling on page 54.

6.3.5.12 DSGetBufferChunkData

```
GC_ERROR DSGetBufferChunkData( DS_HANDLE      hDataStream,
                               BUFFER_HANDLE  hBuffer,
                               SINGLE_CHUNK_DATA * pChunkData,
                               size_t *      piNumChunks )
```

DSGetBufferChunkData parses the transport layer technology dependent chunk data info in the buffer. The layout of the chunk data present in the buffer is returned in the *pChunkData* array, one entry per chunk. Every single chunk is described using its ChunkID, offset in the buffer and chunk data size.

Parameters

[in] *hDataStream* Data Stream module to work on.
 [in] *hBuffer* Buffer handle to parse.

[out] *pChunkData* User allocated array of structures to receive the chunk layout information. If this parameter is NULL, *piNumChunks* will contain the number of chunks in the buffer, i.e. the minimal number of entries in the *pChunkData* array.

[in,out] *piNumChunks* *pChunkData* equal NULL:
 out: number of chunks in the buffer (minimal number of entries in the *pChunkData* array to hold all information)
pChunkData unequal NULL:
 in: number of entries in the provided *pChunkData* array
 out: number of entries successfully written to the *pChunkData* array

Returns

- GC_ERR_SUCCESS Operation was successful; no error occurred.
- GC_ERR_NOT_INITIALIZED No preceding call to [GCInitLib](#)
- GC_ERR_INVALID_HANDLE The handle *hDataStream* is invalid (NULL) or does not reference an open Data Stream module retrieved through a call to [DevOpenDataStream](#) or the handle *hBuffer* is invalid (NULL) or does not reference an announced Buffer module retrieved through a call to [DSAllocAndAnnounce](#) or [DSAnnounceBuffer](#).
- GC_ERR_INVALID_PARAMETER Parameter *piNumChunks* is an invalid pointer (NULL or ~0x0)
- GC_ERR_NO_DATA The Buffer referenced by *hBuffer* does not contain chunk data.
- GC_ERR_BUFFER_TOO_SMALL *pChunkData* is not NULL and the value of **piNumChunks* is too small to receive the expected amount of data.
- GC_ERR_PARSING_CHUNK_DATA An error occurred during the parsing of the chunk buffer.
- GC_ERR_NOT_AVAILABLE The request is implemented but the requested information is currently not available for any reason.

Error cases not covered in the list above may return error codes according to chapter 6.1.5 Error Handling on page 54.

6.3.5.13 DSGetParentDev

```
GC_ERROR DSGetParentDev ( DS_HANDLE hDataStream,
                          DEV_HANDLE * phDevice )
```

Retrieve a handle to the parent Device module.

Parameters

[in] *hDataStream* Data Stream module to work on.
 [out] *phDevice* Handle to the parent Device module .

Returns

GC_ERR_SUCCESS Operation was successful; no error occurred.
 GC_ERR_NOT_INITIALIZED No preceding call to [GCInitLib](#).
 GC_ERR_INVALID_HANDLE The handle *hDataStream* is invalid (NULL) or does not reference an open Data Stream module retrieved through a call to [DevOpenDataStream](#).
 GC_ERR_INVALID_PARAMETER Parameter *phDevice* is an invalid pointer (NULL or ~0x0)

Error cases not covered in the list above may return error codes according to chapter 6.1.5 Error Handling on page 54.

6.3.6 Port Functions

6.3.6.1 GCGetPortInfo

```
GC_ERROR GCGetPortInfo ( PORT_HANDLE hPort,
                        PORT_INFO_CMD iInfoCmd,
                        INFO_DATATYPE * piType,
                        void * pBuffer,
                        size_t * piSize )
```

Queries detailed port information as defined in PORT_INFO_CMD.

Parameters

[in] *hPort* Module or remote device port handle to access Port from.
 [in] *iInfoCmd* Information to be retrieved as defined in PORT_INFO_CMD.
 [out] *piType* Data type of the *pBuffer* content as defined in the PORT_INFO_CMD and INFO_DATATYPE.
 [in,out] *pBuffer* Pointer to a user allocated buffer to receive the requested information. If this parameter is NULL, *piSize* will contain the

[in,out] *piSize*

minimal size of *pBuffer* in bytes. If the *piType* is a string the size includes the terminating 0.

pBuffer equal NULL:
 out: minimal size of *pBuffer* in bytes to hold all information

pBuffer unequal NULL:
 in: size of the provided *pBuffer* in bytes
 out: number of bytes filled by the function

Returns

- GC_ERR_SUCCESS Operation was successful; no error occurred.
- GC_ERR_NOT_INITIALIZED No preceding call to [GCInitLib](#).
- GC_ERR_INVALID_HANDLE The handle *hPort* is invalid (NULL) or does not reference an open module.
- GC_ERR_NOT_IMPLEMENTED Specified *iInfoCmd* is not implemented or the provided module handle does not have a Port module implemented.
- GC_ERR_INVALID_PARAMETER Parameters *piSize* and/or *piType* are invalid pointers (NULL or ~0x0)
- GC_ERR_BUFFER_TOO_SMALL *pBuffer* is not NULL and the value of **piSize* is too small to receive the expected amount of data.
- GC_ERR_NOT_AVAILABLE The request is implemented but the requested information is currently not available for any reason.

Error cases not covered in the list above may return error codes according to chapter 6.1.5 Error Handling on page 54.

6.3.6.2 GCGetPortURL

```
GC_ERROR  GCGetPortURL      ( PORT_HANDLE  hPort,
                             char *          sURL,
                             size_t *       piSize )
```

GCGetPortURL retrieves a URL list with the XML description for the given *hPort*. See 4.1.2 XML Description page 31 for more information about supported URLs. Each URL is terminated with a trailing '\0' and after the last URL are two '\0'.

In case of multiple XMLs in the device the [GCGetNumPortURLs](#) and [GCGetPortURLInfo](#) should be used.

This function has been deprecated. Producers should support the new functions [GCGetNumPortURLs](#) and [GCGetPortURLInfo](#). In this case this function may only return a subset of the available URLs in the string list. It is up to the implementor which URL to return.

Parameters

| | |
|------------------------|--|
| [in] <i>hPort</i> | Module or remote device port handle to access Port from. |
| [in,out] <i>sURL</i> | Pointer to a user allocated string buffer to receive the list of URLs. If this parameter is NULL, <i>piSize</i> will contain the needed size of <i>sURL</i> in bytes. Each entry in the list is 0 terminated. After the last entry there is an additional 0. The size includes the terminating 0 characters. |
| [in,out] <i>piSize</i> | <i>sURL</i> equal NULL: out: minimal size of <i>sURL</i> in bytes to hold all information <i>sURL</i> unequal NULL: in: size of the provided <i>sURL</i> in bytes out: number of bytes filled by the function |

Returns

| | |
|--------------------------|--|
| GC_ERR_SUCCESS | Operation was successful; no error occurred. |
| GC_ERR_NOT_INITIALIZED | No preceding call to GCInitLib |
| GC_ERR_INVALID_HANDLE | The handle <i>hPort</i> is invalid (NULL) or does not reference an open module. |
| GC_ERR_BUFFER_TOO_SMALL | <i>sURL</i> is not NULL and the value of <i>*piSize</i> is too small to receive the expected amount of data. |
| GC_ERR_INVALID_PARAMETER | Parameter <i>piSize</i> is an invalid pointer (NULL or ~0x0) |
| GC_ERR_NOT_IMPLEMENTED | The provided module handle does not have a Port module implemented. |

Error cases not covered in the list above may return error codes according to chapter 6.1.5 Error Handling on page 54.

6.3.6.3 GCGetNumPortURLs

```
GC_ERROR GCGetNumPortURLs ( PORT_HANDLE hPort,
                             uint32_t * piNumURLs )
```

Inquire the number of available URLs for this port.

Parameters

| | |
|------------------------|--|
| [in] <i>hPort</i> | Module or remote device port handle to access Port from. |
| [out] <i>piNumURLs</i> | Number of available URL entries. |

Returns

| | |
|------------------------|--|
| GC_ERR_SUCCESS | Operation was successful; no error occurred. |
| GC_ERR_NOT_INITIALIZED | No preceding call to GCInitLib |

| | |
|--------------------------|---|
| GC_ERR_INVALID_HANDLE | The handle <i>hPort</i> is invalid (NULL) or does not reference an open module. |
| GC_ERR_INVALID_PARAMETER | Parameter <i>piNumURLs</i> is an invalid pointer (NULL or ~0x0) |
| GC_ERR_NOT_IMPLEMENTED | The provided module handle does not have a Port module implemented. |

Error cases not covered in the list above may return error codes according to chapter 6.1.5 Error Handling on page 54.

6.3.6.4 GCGetPortURLInfo

```

GC_ERROR  GCGetPortURLInfo    ( PORT_HANDLE    hPort,
                               uint32_t        iURLIndex,
                               URL_INFO_CMD     iInfoCmd,
                               INFO_DATATYPE *  piType,
                               void *          pBuffer,
                               size_t *        piSize )
    
```

Queries detailed port information as defined in URL_INFO_CMD.

In case a module does not support multiple URLs and/or the related information the function will return GC_ERR_NOT_AVAILABLE for information which cannot be retrieved.

Parameters

| | |
|-------------------------|--|
| [in] <i>hPort</i> | Module or remote device port handle to access Port from. |
| [in] <i>iURLIndex</i> | Index of the URL to query. |
| [in] <i>iInfoCmd</i> | Information to be retrieved as defined in URL_INFO_CMD. |
| [out] <i>piType</i> | Data type of the <i>pBuffer</i> content as defined in the URL URL_INFO_CMD and INFO_DATATYPE. |
| [in,out] <i>pBuffer</i> | Pointer to a user allocated buffer to receive the requested information. If this parameter is NULL, <i>piSize</i> will contain the minimal size of <i>pBuffer</i> in bytes. If the <i>piType</i> is a string the size includes the terminating 0. |
| [in,out] <i>piSize</i> | <i>pBuffer</i> equal NULL: out: minimal size of <i>pBuffer</i> in bytes to hold all information <i>pBuffer</i> unequal NULL: in: size of the provided <i>pBuffer</i> in bytes out: number of bytes filled by the function |

Returns

| | |
|------------------------|--|
| GC_ERR_SUCCESS | Operation was successful; no error occurred. |
| GC_ERR_NOT_INITIALIZED | No preceding call to GCInitLib |

| | |
|--------------------------|---|
| GC_ERR_INVALID_HANDLE | The handle <i>hPort</i> is invalid (NULL) or does not reference an open module. |
| GC_ERR_INVALID_INDEX | <i>iIndex</i> is greater than the number available URLs -1. |
| GC_ERR_NOT_IMPLEMENTED | Specified <i>iInfoCmd</i> is not implemented or the provided module handle does not have a Port module implemented. |
| GC_ERR_NOT_AVAILABLE | The module does not provide the requested information. |
| GC_ERR_NOT_IMPLEMENTED | Specified <i>iInfoCmd</i> is not implemented. |
| GC_ERR_INVALID_PARAMETER | Parameters <i>piSize</i> and/or <i>piType</i> are invalid pointers (NULL or ~0x0). |
| GC_ERR_BUFFER_TOO_SMALL | <i>pBuffer</i> is not NULL and the value of <i>*piSize</i> is too small to receive the expected amount of data. |

Error cases not covered in the list above may return error codes according to chapter 6.1.5 Error Handling on page 54.

6.3.6.5 GCReadPort

```

GC_ERROR  GCReadPort      ( PORT_HANDLE    hPort,
                           uint64_t         iAddress,
                           void *           pBuffer,
                           size_t *        piSize )
    
```

Reads a number of bytes from a given *iAddress* from the specified *hPort*. This is the global GenICam GenApi read access function for all ports implemented in the GenTL implementation. The endianness of the data content is specified by the [GCGetPortInfo](#) function.

If the underlying technology has alignment restrictions on the port read the GenTL Provider implementation has to handle this internally. So for example if the underlying technology only allows a `uint32_t` aligned access and the calling GenTLConsumer wants to read 5 bytes starting at address 2. The implementation has to read 8 bytes starting at address 0 and then it must only return the requested 5 bytes.

Parameters

| | |
|------------------------|---|
| [in] <i>hPort</i> | Module or remote device port handle to access Port from. |
| [in] <i>iAddress</i> | Byte address to read from. |
| [out] <i>pBuffer</i> | Pointer to a user allocated byte buffer to receive data; this must not be NULL. |
| [in,out] <i>piSize</i> | Size of the provided <i>pBuffer</i> and thus the amount of bytes to read from the register map; after the read operation this |

parameter holds the information about the bytes actually read.

Returns

| | |
|---------------------------------------|--|
| <code>GC_ERR_SUCCESS</code> | Operation was successful; no error occurred. |
| <code>GC_ERR_NOT_INITIALIZED</code> | No preceding call to GCInitLib |
| <code>GC_ERR_INVALID_HANDLE</code> | The handle <i>hPort</i> is invalid (NULL) or does not reference an open module. |
| <code>GC_ERR_INVALID_PARAMETER</code> | Parameters <i>pBuffer</i> and/or <i>piSize</i> are invalid pointers (NULL or ~0x0). |
| <code>GC_ERR_ACCESS_DENIED</code> | The access to the requested register <i>iAddress</i> is denied because the register is not readable or because the Port module is opened in a way that it does not allow read access. |
| <code>GC_ERR_INVALID_ADDRESS</code> | <i>iAddress</i> is invalid for example because the port's register space is only 32Bit wide and <i>iAddress</i> is in the 64Bit register space or because there is no register with the provided <i>iAddress</i> . |
| <code>GC_ERR_NOT_IMPLEMENTED</code> | The provided module handle does not have a Port module implemented. |

Error cases not covered in the list above may return error codes according to chapter 6.1.5 Error Handling on page 54.

6.3.6.6 GCWritePort

| | | | | |
|-----------------------|--------------------------|---|---------------------------|------------------------|
| <code>GC_ERROR</code> | <code>GCWritePort</code> | (| <code>PORT_HANDLE</code> | <code>hPort,</code> |
| | | | <code>uint64_t</code> | <code>iAddress,</code> |
| | | | <code>const void *</code> | <code>pBuffer,</code> |
| | | | <code>size_t *</code> | <code>piSize)</code> |

Writes a number of bytes at the given *iAddress* to the specified *hPort*. This is the global GenICam GenApi write access function for all ports implemented in the GenTL implementation. The endianness of the data content is specified by the [GCGetPortInfo](#) function.

If the underlying technology has alignment restrictions on the port write the GenTL Provider implementation has to handle this internally. So for example if the underlying technology only allows a `uint32_t` aligned access and the calling GenTL Consumer wants to write 5 bytes starting at address 2. The implementation has to read 8 bytes starting at address 0, replace the 5 bytes provided and then write the 8 bytes back (read modify write).

Parameters

| | |
|------------------------|---|
| [in] <i>hPort</i> | Module or remote device port handle to access the Port from. |
| [in] <i>iAddress</i> | Byte address to write to. |
| [in] <i>pBuffer</i> | Pointer to a user allocated byte buffer containing the data to write; this must not be NULL. |
| [in,out] <i>piSize</i> | Size of the provided <i>pBuffer</i> and thus the amount of bytes to write to the register map; after the write operation this parameter holds the information about the bytes actually written. |

Returns

| | |
|--------------------------|--|
| GC_ERR_SUCCESS | Operation was successful; no error occurred. |
| GC_ERR_NOT_INITIALIZED | No preceding call to GCInitLib |
| GC_ERR_INVALID_HANDLE | The handle <i>hPort</i> is invalid (NULL) or does not reference an open module. |
| GC_ERR_INVALID_PARAMETER | Parameters <i>pBuffer</i> and/or <i>piSize</i> are invalid pointers (NULL or ~0x0). |
| GC_ERR_ACCESS_DENIED | The access to the requested register <i>iAddress</i> is denied because the register is not writable or because the Port module is opened in a way that it does not allow write access. |
| GC_ERR_INVALID_ADDRESS | <i>iAddress</i> is invalid for example because the port's register space is only 32Bit wide and <i>iAddress</i> is in the 64Bit register space or because there is no register with the provided <i>iAddress</i> . |
| GC_ERR_NOT_IMPLEMENTED | The provided module handle does not have a Port module implemented. |
| GC_ERR_INVALID_VALUE | An invalid value has been written. This error code is to be returned if the underlying registermap provides that information. In case the underlying technology does not provide that level of information a GC_ERR_ACCESS_DENIED is to be returned. |

Error cases not covered in the list above may return error codes according to chapter 6.1.5 Error Handling on page 54.

6.3.6.7 GCWritePortStacked

```
GC_ERROR GCWritePortStacked ( PORT_HANDLE    hPort,
                              PORT_REGISTER_STACK_ENTRY *
                              pEntries,
                              size_t *    piNumEntries )
```

Writes a number of bytes to the given address on the specified *hPort* for every element in the *pEntries* array. The endianness of the data content is specified by the [GCGetPortInfo](#) function.

If the underlying technology has alignment restrictions on the port write the GenTL Provider implementation has to handle this internally. So for example if the underlying technology only allows a `uint32_t` aligned access and the calling GenTL Consumer wants to write 5 bytes starting at address 2. The implementation has to read 8 bytes starting at address 0, replace the 5 bytes provided and then write the 8 bytes back (read/modify/write).

In case of an error the function returns the number of successful writes in *piNumEntries* even though it returns an error code as return value. This is an exception to the statement in the section Error Handling.

Parameters

| | |
|------------------------------|--|
| [in] <i>hPort</i> | Module or remote device port handle to access the Port from. |
| [in] <i>pEntries</i> | Array of structures containing write address and data to write. |
| [in,out] <i>piNumEntries</i> | In: Number of entries in the array, Out: Number of successful executed writes according to the entries in the <i>pEntries</i> array. |

Returns

| | |
|--------------------------|---|
| GC_ERR_SUCCESS | Operation was successful; no error occurred. |
| GC_ERR_NOT_INITIALIZED | No preceding call to GCInitLib |
| GC_ERR_INVALID_HANDLE | The handle <i>hPort</i> is invalid (NULL) or does not reference an open module. |
| GC_ERR_INVALID_PARAMETER | Parameters <i>pEntries</i> and/or <i>piNumEntries</i> are invalid pointers (NULL or ~0x0). |
| GC_ERR_ACCESS_DENIED | The access to at least one of the requested registers is denied because the register is not writable or because the Port module is opened in a way that it does not allow write access. |
| GC_ERR_NOT_IMPLEMENTED | The provided module handle does not have a Port module implemented. |
| GC_ERR_INVALID_ADDRESS | One or more entries in <i>pEntries</i> has an invalid address for example because the port's register space is only 32Bit wide and <i>iAddress</i> is in the 64Bit register space |

or because there is no register with the specified address.

GC_ERR_INVALID_VALUE

An invalid value has been written. This error code is to be returned if the underlying registermap provides that information. In case the underlying technology/registermap does not provide that level of information a GC_ERR_ACCESS_DENIED is to be returned.

Error cases not covered in the list above may return error codes according to chapter 6.1.5 Error Handling on page 54.

6.3.6.8 GCReadPortStacked

```
GC_ERROR GCReadPortStacked ( PORT_HANDLE hPort,
                             PORT_REGISTER_STACK_ENTRY *
                             pEntries,
                             size_t * piNumEntries )
```

Reads a number of bytes from the given address on the specified *hPort* for every element in the *pEntries* array. The endianness of the data content is specified by the [GCGetPortInfo](#) function.

If the underlying technology has alignment restrictions on the port access the GenTL Provider implementation has to handle this internally. So for example if the underlying technology only allows a `uint32_t` aligned access and the calling GenTL Consumer wants to read 5 bytes starting at address 2. The implementation has to read 8 bytes starting at address 0 and to extract the 5 bytes requested.

In case of an error the function returns the number of successful reads in *piNumEntries* even though it returns an error code as return value. This is an exception to the statement in the section Error Handling.

Parameters

| | |
|------------------------------|---|
| [in] <i>hPort</i> | Module or remote device port handle to access the Port from. |
| [in] <i>pEntries</i> | Array of structures containing read address and data to read. |
| [in,out] <i>piNumEntries</i> | In: Number of entries in the array, Out: Number of successful executed reads according to the entries in the <i>pEntries</i> array. |

Returns

| | |
|------------------------|---|
| GC_ERR_SUCCESS | Operation was successful; no error occurred. |
| GC_ERR_NOT_INITIALIZED | No preceding call to GCInitLib |
| GC_ERR_INVALID_HANDLE | The handle <i>hPort</i> is invalid (NULL) or does not reference an open module. |

| | |
|--------------------------|--|
| GC_ERR_INVALID_PARAMETER | Parameters <i>pEntries</i> and/or <i>piNumEntries</i> are invalid pointers (NULL or ~0x0). |
| GC_ERR_ACCESS_DENIED | The access to at least one of the requested registers is denied because the register is not readable or because the Port module is opened in a way that it does not allow read access. |
| GC_ERR_NOT_IMPLEMENTED | The provided module handle does not have a Port module implemented. |
| GC_ERR_INVALID_ADDRESS | One or more addresses in the entries in <i>pEntries</i> has an invalid address for example because the port's register space is only 32Bit wide and <i>iAddress</i> is in the 64Bit register space or because there is no register with the specified address. |

Error cases not covered in the list above may return error codes according to chapter 6.1.5 Error Handling on page 54.

6.3.7 Signaling Functions

6.3.7.1 EventFlush

| | |
|---------------------|--------------------------------|
| GC_ERROR EventFlush | (EVENT_HANDLE <i>hEvent</i>) |
|---------------------|--------------------------------|

Flushes all events in the given *hEvent* object. This call empties the event data queue.

Parameters

[in] *hEvent* Event handle to flush queue on.

Returns

| | |
|------------------------|---|
| GC_ERR_SUCCESS | Operation was successful; no error occurred. |
| GC_ERR_NOT_INITIALIZED | No preceding call to GCInitLib |
| GC_ERR_INVALID_HANDLE | The handle <i>hEvent</i> is invalid (NULL) or does not reference a previously registered event. |

Error cases not covered in the list above may return error codes according to chapter 6.1.5 Error Handling on page 54.

6.3.7.2 EventGetData

```
GC_ERROR EventGetData ( EVENT_HANDLE hEvent,
                        void * pBuffer,
                        size_t * piSize,
                        uint64_t iTimeout )
```

Retrieves the next event data entry from the event data queue associated with the *hEvent*.

The data content can be queried by the [EventGetDataInfo](#) function.

The default buffer size which can hold all the event data can be queried with the [EventGetInfo](#) function. This needs to be queried only once. The default size must not change during runtime.

In case of a New Buffer event the EventGetData function return the EVENT_NEW_BUFFER_DATA structure in the provided buffer.

In case EventGetData returns an error (for example GC_ERR_ABORT) no event is removed from the internal queue and the event stays signaled. Event counters are not affected.

Parameters

| | | |
|----------|-----------------|---|
| [in] | <i>hEvent</i> | Event handle to wait for |
| [out] | <i>pBuffer</i> | Pointer to a user allocated buffer to receive the event data. The data type of the buffer is dependent on the event ID of the <i>hEvent</i> . If this value is NULL the data is removed from the queue without being delivered. |
| [in,out] | <i>piSize</i> | Size of the provided <i>pBuffer</i> in bytes; after the write operation this parameter holds the information about the bytes actually written. |
| [in] | <i>iTimeout</i> | Timeout for the wait in ms. If set to GENTL_INFINITE the timeout is infinite and the function will only return if the operation is completed or if EventKill is called on this event object. A value of 0 checks the state of the event object and returns immediately either with a timeout or with event data. |

Returns

| | |
|--------------------------|---|
| GC_ERR_SUCCESS | Operation was successful; no error occurred. |
| GC_ERR_NOT_INITIALIZED | No preceding call to GCInitLib . |
| GC_ERR_INVALID_HANDLE | The handle <i>hEvent</i> is invalid (NULL) or does not reference a previously registered event. |
| GC_ERR_INVALID_PARAMETER | Parameter <i>piSize</i> is an invalid pointer (NULL or ~0x0). |
| GC_ERR_BUFFER_TOO_SMALL | <i>pBuffer</i> is not NULL and the value of <i>*piSize</i> is too small to receive the expected amount of data. |

| | |
|----------------|--|
| GC_ERR_ABORT | The current wait operation has been terminated through a call to EventKill . |
| GC_ERR_TIMEOUT | The specified <i>iTimeout</i> expired before the event <i>hEvent</i> occurred. |

Error cases not covered in the list above may return error codes according to chapter 6.1.5 Error Handling on page 54.

6.3.7.3 EventGetDataInfo

```
GC_ERROR  EventGetDataInfo  (  EVENT_HANDLE  hEvent,
                               const void *    pInBuffer,
                               size_t          iInSize,
                               EVENT_DATA_INFO_CMD iInfoCmd,
                               INFO_DATATYPE *  piType,
                               void *          pOutBuffer,
                               size_t *        piOutSize )
```

Parses the transport layer technology dependent event info.

Parameters

| | |
|----------------------------|---|
| [in] <i>hEvent</i> | Event handle to parse data from. |
| [in] <i>pInBuffer</i> | Pointer to a buffer containing event data. This value must not be NULL. |
| [in] <i>iInSize</i> | Size of the provided <i>pInBuffer</i> in bytes |
| [in] <i>iInfoCmd</i> | Information to be retrieved as defined in EVENT_DATA_INFO_CMD and EVENT_TYPE. |
| [out] <i>piType</i> | Data type of the <i>pOutBuffer</i> content as defined in the EVENT_DATA_INFO_CMD, EVENT_TYPE and INFO_DATATYPE. |
| [in,out] <i>pOutBuffer</i> | Pointer to a user allocated buffer to receive the requested information. If this parameter is NULL, <i>piOutSize</i> will contain the minimal size of <i>pOutBuffer</i> in bytes. If the <i>piType</i> is a string the size includes the terminating 0. |
| [in,out] <i>piOutSize</i> | <i>pOutBuffer</i> equal NULL: out: minimal size of <i>pOutBuffer</i> in bytes to hold all information <i>pOutBuffer</i> unequal NULL: in: size of the provided <i>pOutBuffer</i> in bytes out: number of bytes filled by the function |

Returns

| | |
|------------------------|--|
| GC_ERR_SUCCESS | Operation was successful; no error occurred. |
| GC_ERR_NOT_INITIALIZED | No preceding call to GCInitLib |

| | |
|--------------------------|--|
| GC_ERR_INVALID_HANDLE | The handle <i>hEvent</i> is invalid (NULL or ~ 0x0) or does not reference a previously registered event or <i>pInBuffer</i> is invalid (NULL or ~0x0). |
| GC_ERR_NOT_IMPLEMENTED | Specified <i>iInfoCmd</i> is not implemented. |
| GC_ERR_INVALID_PARAMETER | Parameters <i>piOutSize</i> and/or <i>piType</i> are invalid pointers (NULL or ~0x0) or <i>iInSize</i> is 0 |
| GC_ERR_BUFFER_TOO_SMALL | <i>pOutBuffer</i> is not NULL and the value of <i>*piOutSize</i> is too small to receive the expected amount of data. |
| GC_ERR_NOT_AVAILABLE | The request is implemented but the requested information is currently not available for any reason. |

Error cases not covered in the list above may return error codes according to chapter 6.1.5 Error Handling on page 54.

6.3.7.4 EventGetInfo

```
GC_ERROR  EventGetInfo      (  EVENT_HANDLE      hEvent,
                             EVENT_INFO_CMD    iInfoCmd,
                             INFO_DATATYPE *   piType,
                             void *           pBuffer,
                             size_t *         piSize )
```

Retrieves information about the given *hEvent* object as defined in EVENT_INFO_CMD.

Parameters

| | |
|-------------------------|---|
| [in] <i>hEvent</i> | Event handle to retrieve info from. |
| [in] <i>iInfoCmd</i> | Information to be retrieved as defined in EVENT_INFO_CMD. |
| [out] <i>piType</i> | Data type of the <i>pBuffer</i> content as defined in the EVENT_INFO_CMD and INFO_DATATYPE. |
| [in,out] <i>pBuffer</i> | Pointer to a user allocated buffer to receive the requested information. If this parameter is NULL, <i>piSize</i> will contain the minimal size of <i>pBuffer</i> in bytes. If the <i>piType</i> is a string the size includes the terminating 0. |
| [in,out] <i>piSize</i> | <i>pBuffer</i> equal NULL: out: minimal size of <i>pBuffer</i> in bytes to hold all information <i>pBuffer</i> unequal NULL: in: size of the provided <i>pBuffer</i> in bytes out: number of bytes filled by the function |

Returns

| | |
|----------------|--|
| GC_ERR_SUCCESS | Operation was successful; no error occurred. |
|----------------|--|

| | |
|--------------------------|---|
| GC_ERR_NOT_INITIALIZED | No preceding call to GCInitLib |
| GC_ERR_INVALID_HANDLE | The handle <i>hEvent</i> is invalid (NULL) or does not reference a previously registered event. |
| GC_ERR_NOT_IMPLEMENTED | Specified <i>iInfoCmd</i> is not implemented. |
| GC_ERR_INVALID_PARAMETER | Parameters <i>piSize</i> and/or <i>piType</i> are invalid pointers (NULL or ~0x0) |
| GC_ERR_BUFFER_TOO_SMALL | <i>pBuffer</i> is not NULL and the value of <i>*piSize</i> is too small to receive the expected amount of data. |
| GC_ERR_NOT_AVAILABLE | The request is implemented but the requested information is currently not available for any reason. |

Error cases not covered in the list above may return error codes according to chapter 6.1.5 Error Handling on page 54.

6.3.7.5 EventKill

| | |
|--------------------|--------------------------------|
| GC_ERROR EventKill | (EVENT_HANDLE <i>hEvent</i>) |
|--------------------|--------------------------------|

Terminate a waiting operation on a previously registered event object. In case of multiple pending wait operations `EventKill` causes one wait operation to return with a [GC_ERR_ABORT](#) error code. Therefore in order to cancel all pending wait operations `EventKill` must be called as many times as wait operations are pending. In case this function is called while no wait operation was pending the next call to [EventGetData](#) will return a [GC_ERR_ABORT](#). This behavior can be cleared by unregistering and reregistering the event.

In case there are pending events in the queue the `EventKill` has higher priority and on the pending/next call to [EventGetData](#) a [GC_ERR_ABORT](#) is returned.

`EventKill` does not free any resources.

Parameters

[in] *hEvent* Handle to event object.

Returns

| | |
|------------------------|---|
| GC_ERR_SUCCESS | Operation was successful; no error occurred. |
| GC_ERR_NOT_INITIALIZED | No preceding call to GCInitLib |
| GC_ERR_INVALID_HANDLE | The handle <i>hEvent</i> is invalid (NULL) or does not reference a previously registered event. |

Error cases not covered in the list above may return error codes according to chapter 6.1.5 Error Handling on page 54.

6.3.7.6 GCRegisterEvent

```
GC_ERROR GCRegisterEvent ( EVENTSRC_HANDLE hModule,
                          EVENT_TYPE      iEventID,
                          EVENT_HANDLE *   phEvent )
```

Registers an event object to a certain *iEventID*. The implementation might change depending on the platform.

Every event registered must be unregistered with the [GCUnregisterEvent](#) function.

Parameters

| | |
|----------------------|--|
| [in] <i>hModule</i> | Module handle to access to register event to. |
| [in] <i>iEventID</i> | Event type to register as defined in <code>EVENT_TYPE</code> . |
| [out] <i>phEvent</i> | New handle to an event object to work with. It is recommended to initialize <i>*phEvent</i> to <code>GENTL_INVALID_HANDLE</code> before calling GCRegisterEvent to indicate an invalid handle. |

Returns

| | |
|-------------------------------------|--|
| <code>GC_ERR_SUCCESS</code> | Operation was successful; no error occurred. |
| <code>GC_ERR_NOT_INITIALIZED</code> | No preceding call to GCInitLib |
| <code>GC_ERR_INVALID_HANDLE</code> | The handle <i>hModule</i> is invalid (NULL) or does not reference a previously instantiated module. |
| <code>GC_ERR_RESOURCE_IN_USE</code> | The given <i>iEventID</i> has been registered before on the given <i>hModule</i> . |
| <code>GC_ERR_NOT_IMPLEMENTED</code> | The specified event type is not implemented in the provided module of the GenTL Producer. |
| <code>GC_ERR_NOT_AVAILABLE</code> | The specified event type is not available in the provided module <i>hModule</i> (for example because the remote device does not implement it). |

Error cases not covered in the list above may return error codes according to chapter 6.1.5 Error Handling on page 54.

6.3.7.7 GCUnregisterEvent

```
GC_ERROR GCUnregisterEvent ( EVENTSRC_HANDLE hModule,
                             EVENT_TYPE      iEventID )
```

A call to this function will unregister the given *iEventID* from the given *hModule*. This will terminate all pending wait operations of [EventGetData](#) with an error code [GC_ERR_ABORT](#). Pending events are silently discarded.

Parameters

- [in] *hModule* Module handle to unregister event with.
- [in] *iEventID* Event type to unregister as defined in `EVENT_TYPE`.

Returns

- `GC_ERR_SUCCESS` Operation was successful; no error occurred.
- `GC_ERR_NOT_INITIALIZED` The event has not previously been registered through [GCRegisterEvent](#) or no preceding call to [GCInitLib](#) has been made.
- `GC_ERR_INVALID_HANDLE` The handle *hModule* is invalid (NULL) or does not reference a previously instantiated module.
- `GC_ERR_NOT_IMPLEMENTED` The specified event type is not implemented in the provided module of the GenTL Producer.

Error cases not covered in the list above may return error codes according to chapter 6.1.5 Error Handling on page 54.

6.4 Enumerations

Enumeration values are signed 32 bit integers.

6.4.1 Library and System Enumerations

6.4.1.1 INFO_DATATYPE

```
enum INFO_DATATYPE
```

Defines the data type possible for the various Info functions. The data type itself may define its size. For buffer or string types the *piSize* parameter must be used to query the actual amount of data being written.

| Enumerator | Value | Description |
|------------------------------------|-------|---|
| <code>INFO_DATATYPE_UNKNOWN</code> | 0 | Unknown data type. This value is never returned from a function but can be used to initialize the variable to |

| Enumerator | Value | Description |
|--------------------------|-------|--|
| | | inquire the type. |
| INFO_DATATYPE_STRING | 1 | 0-terminated C string (encoding according to the TL_INFO_CHAR_ENCODING info command). |
| INFO_DATATYPE_STRINGLIST | 2 | Concatenated INFO_DATATYPE_STRING list. End of list is signaled with an additional 0. |
| INFO_DATATYPE_INT16 | 3 | Signed 16 bit integer. |
| INFO_DATATYPE_UINT16 | 4 | Unsigned 16 bit integer. |
| INFO_DATATYPE_INT32 | 5 | Signed 32 bit integer. |
| INFO_DATATYPE_UINT32 | 6 | Unsigned 32 bit integer. |
| INFO_DATATYPE_INT64 | 7 | Signed 64 bit integer. |
| INFO_DATATYPE_UINT64 | 8 | Unsigned 64 bit integer. |
| INFO_DATATYPE_FLOAT64 | 9 | Signed 64 bit floating point number. |
| INFO_DATATYPE_PTR | 10 | Pointer type (void*). Size is platform dependent (32 bit on 32 bit platforms) |
| INFO_DATATYPE_BOOL8 | 11 | Boolean value occupying 8 bit. 0 for false and anything for true. |
| INFO_DATATYPE_SIZET | 12 | Platform dependent unsigned integer (32 bit on 32 bit platforms) |
| INFO_DATATYPE_BUFFER | 13 | Like a INFO_DATATYPE_STRING but with arbitrary data and no 0 termination. |
| INFO_DATATYPE_PTRDIFF | 14 | The type ptrdiff_t is a type that can hold the result of subtracting two pointers. |
| INFO_DATATYPE_CUSTOM_ID | 1000 | Starting value for Custom IDs which are implementation specific. If a generic GenTL Consumer is using custom data types provided through a specific GenTL Producer implementation it must differentiate the handling of GenTL Producer implementations in case other implementations will not provide that custom id or will use a different meaning with it. |

6.4.1.2 TL_CHAR_ENCODING_LIST

```
enum TL_CHAR_ENCODING_LIST
```

Char encoding schemata

| Enumerator | Value | Description |
|------------------------|-------|--|
| TL_CHAR_ENCODING_ASCII | 0 | Char encoding of the GenTL Producer is ASCII |
| TL_CHAR_ENCODING_UTF8 | 1 | Char encoding of the GenTL Producer is UTF8 |

6.4.1.3 TL_INFO_CMD

```
enum TL_INFO_CMD
```

System module information commands for the [TLGetInfo](#) and [GCGetInfo](#) functions.

| Enumerator | Value | Description |
|-----------------|-------|--|
| TL_INFO_ID | 0 | Unique ID identifying a GenTL Producer. For example the filename of the GenTL Producer implementation incl. its path. Data type: STRING |
| TL_INFO_VENDOR | 1 | GenTL Producer vendor name. Data type: STRING |
| TL_INFO_MODEL | 2 | GenTL Producer model name. For example: Assuming a vendor produces more than one GenTL Producer for different device classes or different technologies the Model references a single GenTL Producer implementation. The combination of Vendor and Model provides a unique reference of ONE GenTL Producer implementation. Data type: STRING |
| TL_INFO_VERSION | 3 | GenTL Producer version. Data type: STRING |
| TL_INFO_TLTYPE | 4 | Transport layer technology that is supported. See string constants in chapter 6.6.1. Data type: STRING |
| TL_INFO_NAME | 5 | File name including extension of the library. Data type: STRING |

| Enumerator | Value | Description |
|-----------------------|-------|---|
| TL_INFO_PATHNAME | 6 | Full path including file name and extension of the library. Data type: STRING |
| TL_INFO_DISPLAYNAME | 7 | User readable name of the GenTL Producer. Data type: STRING |
| TL_INFO_CHAR_ENCODING | 8 | The char encoding of the GenTL Producer. Data type: INT32 (TL_CHAR_ENCODING_LIST enumeration value) Data type: INT32 |
| TL_INFO_CUSTOM_ID | 1000 | Starting value for GenTL Producer custom IDs which are implementation specific. If a generic GenTL Consumer is using custom TL_INFO_CMDs provided through a specific GenTL Producer implementation it must differentiate the handling of different GenTL Producer implementations in case other implementations will not provide that custom id or will use a different meaning with it. |

6.4.2 Interface Enumerations

6.4.2.1 INTERFACE_INFO_CMD

```
enum INTERFACE_INFO_CMD
```

This enumeration defines commands to retrieve information with the [IFGetInfo](#) function from the Interface module.

| Enumerator | Value | Description |
|----------------------------|-------|---|
| INTERFACE_INFO_ID | 0 | Unique ID of the interface. Data type: STRING |
| INTERFACE_INFO_DISPLAYNAME | 1 | User readable name of the interface. Data type: STRING |
| INTERFACE_INFO_TLTYPE | 2 | Transport layer technology that is supported. See string constants in chapter 6.6.1. Data type: STRING |
| INTERFACE_INFO_CUSTOM_ID | 1000 | Starting value for GenTL Producer |

| Enumerator | Value | Description |
|------------|-------|---|
| | | custom IDs which are implementation specific. If a generic GenTL Consumer is using custom <code>INTERFACE_INFO_CMDS</code> provided through a specific GenTL Producer implementation it must differentiate the handling of different GenTL Producer implementations in case other implementations will not provide that custom id or will use a different meaning with it. |

6.4.3 Device Enumerations

6.4.3.1 DEVICE_ACCESS_FLAGS

```
enum DEVICE_ACCESS_FLAGS
```

This enumeration defines flags how a device is to be opened with the [IFOpenDevice](#) function. Also possible results are defined.

| Enumerator | Value | Description |
|--------------------------------------|-------|---|
| <code>DEVICE_ACCESS_UNKNOWN</code> | 0 | Not used in a command. Can be used to initialize a variable to query that information. |
| <code>DEVICE_ACCESS_NONE</code> | 1 | This either means that the device is not open because it was not opened before or the access to it was denied. |
| <code>DEVICE_ACCESS_READONLY</code> | 2 | Open the device read only. All Port functions can only read from the device. |
| <code>DEVICE_ACCESS_CONTROL</code> | 3 | Open the device in a way that other hosts/processes can have read only access to the device. Device access level is read/write for this process. |
| <code>DEVICE_ACCESS_EXCLUSIVE</code> | 4 | Open the device in a way that only this host/process can have access to the device. Device access level is read/write for this process. |
| <code>DEVICE_ACCESS_CUSTOM_ID</code> | 1000 | Starting value for GenTL Producer custom IDs which are implementation specific. If a generic GenTL Consumer is using custom <code>DEVICE_ACCESS_FLAGS</code> provided through a specific GenTL |

| Enumerator | Value | Description |
|------------|-------|---|
| | | Producer implementation it must differentiate the handling of different GenTL Producer implementations in case other implementations will not provide that custom id or will use a different meaning with it. |

6.4.3.2 DEVICE_ACCESS_STATUS

```
enum DEVICE_ACCESS_STATUS
```

This enumeration defines the status codes used in the info functions to retrieve the current accessibility of the device.

| Enumerator | Value | Description |
|--------------------------------|-------|--|
| DEVICE_ACCESS_STATUS_UNKNOWN | 0 | The current availability of the device is unknown. |
| DEVICE_ACCESS_STATUS_READWRITE | 1 | The device is available for Read/Write access |
| DEVICE_ACCESS_STATUS_READONLY | 2 | The device is available for Read access. |
| DEVICE_ACCESS_STATUS_NOACCESS | 3 | The device is not available either because it is already open or because it is not reachable. |
| DEVICE_ACCESS_STATUS_CUSTOM_ID | 1000 | Starting value for custom IDs which are implementation specific. If a generic GenTL Consumer is using custom DEVICE_ACCESS_STATUS ids provided through a specific GenTL Producer implementation it must differentiate the handling of different GenTL Producer implementations in case other implementations will not provide that custom id or will use a different meaning with it. |

6.4.3.3 DEVICE_INFO_CMD

```
enum DEVICE_INFO_CMD
```

This enumeration defines commands to retrieve information with the [DevGetInfo](#) function on a device handle.

| Enumerator | Value | Description |
|----------------|-------|--------------------------|
| DEVICE_INFO_ID | 0 | Unique ID of the device. |

| Enumerator | Value | Description |
|---------------------------------|-------|---|
| | | Data type: STRING |
| DEVICE_INFO_VENDOR | 1 | Device vendor name. Data type: STRING |
| DEVICE_INFO_MODEL | 2 | Device model name. Data type: STRING |
| DEVICE_INFO_TLTYPE | 3 | Transport layer technology that is supported. See string constants in chapter 6.6.1. Data type: STRING |
| DEVICE_INFO_DISPLAYNAME | 4 | User readable name of the device. If this is not defined in the device this should be “VENDOR MODEL (ID)” Data type: STRING |
| DEVICE_INFO_ACCESS_STATUS | 5 | Gets the access status the GenTL Producer has on the device. Data type: INT32 (DEVICE_ACCESS_STATUS enumeration value) |
| DEVICE_INFO_USER_DEFINED_NAME | 6 | String containing the user defined name of the device. If the information is not available, the query should result in GC_ERR_NOT_AVAILABLE. Data type: STRING |
| DEVICE_INFO_SERIAL_NUMBER | 7 | Serial number of the device in string format. If the information is not available, the query should result in GC_ERR_NOT_AVAILABLE. Data type: STRING |
| DEVICE_INFO_VERSION | 8 | Device version in string format. If the information is not known, the query should result in GC_ERR_NOT_AVAILABLE Data type: STRING |
| DEVICE_INFO_TIMESTAMP_FREQUENCY | 9 | Tick frequency of the device’s timestamp counter in ticks per second. The counter is used for example to assign timestamps to the individual acquired buffers (BUFFER_INFO_TIMESTAMP). Data type: UINT64 |
| DEVICE_INFO_CUSTOM_ID | 1000 | Starting value for GenTL Producer custom IDs which are implementation |

| Enumerator | Value | Description |
|------------|-------|--|
| | | specific. If a generic GenTL Consumer is using custom <code>DEVICE_INFO_COMMANDS</code> provided through a specific GenTL Producer implementation it must differentiate the handling of different GenTL Producer implementations in case other implementations will not provide that custom id or will use a different meaning with it. |

6.4.4 Data Stream Enumerations

6.4.4.1 ACQ_QUEUE_TYPE

```
enum ACQ_QUEUE_TYPE
```

This enumeration commands from which to which queue/pool buffers are flushed with the [DSFlushQueue](#) function.

| Enumerator | Value | Description |
|--|-------|---|
| <code>ACQ_QUEUE_INPUT_TO_OUTPUT</code> | 0 | Flushes the buffers from the input pool to the output buffer queue and if necessary adds entries in the “New Buffer” event data queue. The buffers currently being filled are not affected by this operation. This only applies to the mandatory default buffer handling mode. The fill state of a buffer can be inquired through the buffer info command <code>BUFFER_INFO_NEW_DATA</code> . This allows the GenTL Consumer to maintain all buffers without a second reference in the GenTL Consumer because all buffers are delivered through the new buffer event. |
| <code>ACQ_QUEUE_OUTPUT_DISCARD</code> | 1 | Discards all buffers in the output buffer queue and if necessary remove the entries from the event data queue. |
| <code>ACQ_QUEUE_ALL_TO_INPUT</code> | 2 | Puts all buffers in the input pool. This is including those in the output buffer queue and the ones which are currently being filled and discard entries in the event data queue. |

| Enumerator | Value | Description |
|-----------------------------|-------|--|
| ACQ_QUEUE_UNQUEUED_TO_INPUT | 3 | Puts all buffers that are neither in the input pool nor being currently filled nor in the output buffer queue in the input pool. |
| ACQ_QUEUE_ALL_DISCARD | 4 | Discards all buffers in the input pool and the buffers in the output queue including buffers currently being filled so that no buffer is bound to any internal mechanism and all buffers may be revoked or requeued. |
| ACQ_QUEUE_CUSTOM_ID | 1000 | Starting value for GenTL Producer custom IDs which are implementation specific. If a generic GenTL Consumer is using custom ACQ_QUEUE_TYPES provided through a specific GenTL Producer implementation it must differentiate the handling of different GenTL Producer implementations in case other implementations will not provide that custom id or will use a different meaning with it. |

6.4.4.2 ACQ_START_FLAGS

```
enum ACQ_START_FLAGS
```

This enumeration defines special start flags for the acquisition engine. The function used is DSStartAcquisition.

| Enumerator | Value | Description |
|---------------------------|-------|---|
| ACQ_START_FLAGS_DEFAULT | 0 | Default behavior. |
| ACQ_START_FLAGS_CUSTOM_ID | 1000 | Starting value for GenTL Producer custom IDs. |

6.4.4.3 ACQ_STOP_FLAGS

```
enum ACQ_STOP_FLAGS
```

This enumeration defines special stop flags for the acquisition engine. The function used is DSStopAcquisition.

| Enumerator | Value | Description |
|------------------------|-------|--------------------------------------|
| ACQ_STOP_FLAGS_DEFAULT | 0 | Stop the acquisition engine when the |

| Enumerator | Value | Description |
|--------------------------|-------|---|
| | | currently running tasks like filling a buffer are completed (default behavior). |
| ACQ_STOP_FLAGS_KILL | 1 | Stop the acquisition engine immediately. In case this results in a partially filled buffer the Producer will return the buffer through the regular mechanism to the user, indicating through the info function of that buffer that this buffer is not complete. |
| ACQ_STOP_FLAGS_CUSTOM_ID | 1000 | Starting value for GenTL Producer custom IDs which are implementation specific. If a generic GenTL Consumer is using custom ACQ_STOP_FLAGS provided through a specific GenTL Producer implementation it must differentiate the handling of different GenTL Producer implementations in case other implementations will not provide that custom id or will use a different meaning with it. |

6.4.4.4 BUFFER_INFO_CMD

```
enum BUFFER_INFO_CMD
```

This enumeration defines commands to retrieve information with the [DSGetBufferInfo](#) function on a buffer handle. In case a BUFFER_INFO_CMD is not available or not implemented the [DSGetBufferInfo](#) function must return the appropriate error return value.

| Enumerator | Value | Description |
|----------------------|-------|--|
| BUFFER_INFO_BASE | 0 | Base address of the buffer memory as passed to the DSAnnounceBuffer function. This is also the address where the payload within the buffer starts. Data type: PTR |
| BUFFER_INFO_SIZE | 1 | Size of the buffer in bytes. Data type: SIZET |
| BUFFER_INFO_USER_PTR | 2 | Private data pointer casted to an integer provided at buffer announcement using DSAnnounceBuffer or |

| Enumerator | Value | Description |
|---------------------------|-------|---|
| | | <u>DSAllocAndAnnounceBuffer</u> by the GenTL Consumer. The pointer is attached to the buffer to allow attachment of user data to a buffer. Data type: PTR |
| BUFFER_INFO_TIMESTAMP | 3 | Timestamp the buffer was acquired. The unit is device/implementation dependent. In case the technology and/or the device does not support this for example under Windows a QueryPerformanceCounter can be used. Data type: UINT64 |
| BUFFER_INFO_NEW_DATA | 4 | Flag to indicate that the buffer contains new data since the last delivery. Data type: BOOL8 |
| BUFFER_INFO_IS_QUEUED | 5 | If this flag is set to true the buffer is in the input pool, the buffer is currently being filled or the buffer is in the output buffer queue. In case this value is true the buffer is owned by the GenTL Producer and it can not be revoked. Data type: BOOL8 |
| BUFFER_INFO_IS_ACQUIRING | 6 | Flag to indicate that the buffer is currently being filled with data. Data type: BOOL8 |
| BUFFER_INFO_IS_INCOMPLETE | 7 | Flag to indicate that a buffer was filled but an error occurred during that process. Data type: BOOL8 |
| BUFFER_INFO_TLTYPE | 8 | Transport layer technology that is supported. See string constants in chapter 6.6.1. Data type: STRING |
| BUFFER_INFO_SIZE_FILLED | 9 | Number of bytes written into the buffer the last time it has been filled. This value is reset to 0 when the buffer is placed into the Input Buffer Pool. If the buffer is incomplete (such as if there are missing packets), only the number of bytes successfully written |

| Enumerator | Value | Description |
|----------------------|-------|---|
| | | to the buffer are reported. If the buffer is complete, the number equals to the size reported through BUFFER_INFO_DATA_SIZE. Data type: SIZET |
| BUFFER_INFO_WIDTH | 10 | Width of the data in the buffer in number of pixels. This information refers for example to the width entry in the GigE Vision image stream data leader. For other technologies this is to be implemented accordingly. Data type: SIZET |
| BUFFER_INFO_HEIGHT | 11 | Height of the data in the buffer in number of pixels as configured. For variable size images this is the max Height of the buffer. For example this information refers to the height entry in the GigE Vision image stream data leader. For other technologies this is to be implemented accordingly. Data type: SIZET |
| BUFFER_INFO_XOFFSET | 12 | XOffset of the data in the buffer in number of pixels from the image origin to handle areas of interest. This information refers for example to the information provided in the GigE Vision image stream data leader. For other technologies this is to be implemented accordingly. Data type: SIZET |
| BUFFER_INFO_YOFFSET | 13 | YOffset of the data in the buffer in number of lines from the image origin to handle areas of interest. This information refers for example to the information provided in the GigE Vision image stream data leader. For other technologies this is to be implemented accordingly. Data type: SIZET |
| BUFFER_INFO_XPADDING | 14 | XPadding of the data in the buffer in number of bytes. This information refers for example to the information provided in the GigE Vision image |

| Enumerator | Value | Description |
|--------------------------|-------|---|
| | | stream data leader. For other technologies this is may be implemented accordingly. Data type: SIZET |
| BUFFER_INFO_Y_PADDING | 15 | YPadding of the data in the buffer in number of bytes. This information refers for example to the information provided in the GigE Vision image stream data leader. For other technologies this may be implemented accordingly. Data type: SIZET |
| BUFFER_INFO_FRAMEID | 16 | A sequentially incremented number of the frame. This information refers for example to the information provided in the GigE Vision image stream block id. For other technologies this is to be implemented accordingly. The wrap around of this number is transportation technology dependent. For GigE Vision it is (so far) 16bit wrapping to 1. Other technologies may implement a larger bit depth. Data type: UINT64 |
| BUFFER_INFO_IMAGEPRESENT | 17 | Flag to indicate if the current data in the buffer contains image data. This information refers for example to the information provided in the GigE Vision image stream data leader. For other technologies this is to be implemented accordingly. Data type: BOOL8 |
| BUFFER_INFO_IMAGEOFFSET | 18 | Offset of the image data from the beginning of the delivered buffer in bytes. Applies for example when delivering the image as part of chunk data or on technologies requiring specific buffer alignment. Data type: SIZET |
| BUFFER_INFO_PAYLOADTYPE | 19 | Payload type of the data. This information refers to the constants defined in PAYLOADTYPE_INFO_IDS. Data type: SIZET |

| Enumerator | Value | Description |
|--|-------|---|
| BUFFER_INFO_PIXELFORMAT | 20 | This information refers for example to the information provided in the GigE Vision image stream data leader. For other technologies this is to be implemented accordingly. The interpretation of the pixel format depends on the namespace the pixel format belongs to. This can be inquired using the BUFFER_INFO_PIXELFORMAT_NAMESPACE command. Data type: UINT64 |
| BUFFER_INFO_PIXELFORMAT_NAMESPACE | 21 | This information refers to the constants defined in PIXELFORMAT_NAMESPACE_IDS to allow interpretation of BUFFER_INFO_PIXELFORMAT. Data type: UINT64 |
| BUFFER_INFO_DELIVERED_IMAGEHEIGHT | 22 | The number of lines in the current buffer as delivered by the transport mechanism. For area scan type images this is usually the number of lines configured in the device. For variable size linescan images this number may be lower than the configured image height. This information refers for example to the information provided in the GigE Vision image stream data trailer. For other technologies this is to be implemented accordingly. Data type: SIZET |
| BUFFER_INFO_DELIVERED_CHUNKPAYLOADSIZE | 23 | This information refers for example to the information provided in the GigE Vision image stream data trailer. For other technologies this is to be implemented accordingly. Data type: SIZET |
| BUFFER_INFO_CHUNKLAYOUTID | 24 | This information refers for example to the information provided in the GigE Vision image stream data leader. The chunk layout id serves as an indicator that the chunk layout has changed and the application should |

| Enumerator | Value | Description |
|------------------------------|-------|---|
| | | <p>re-parse the chunk layout in the buffer. When a chunk layout (availability or position of individual chunks) changes since the last buffer delivered by the device through the same stream, the device MUST change the chunk layout id. As long as the chunk layout remains stable, the camera MUST keep the chunk layout id intact. When switching back to a layout, which was already used before, the camera can use the same id again or use a new id. A chunk layout id value of 0 is invalid. It is reserved for use by cameras not supporting the layout id functionality. The algorithm used to compute the chunk layout id is left as quality of implementation. For other technologies this is to be implemented accordingly.</p> <p>Data type: UINT64</p> |
| BUFFER_INFO_FILENAME | 25 | <p>This information refers for example to the information provided in the GigE Vision image stream data leader. For other technologies this is to be implemented accordingly. Since this is GigE Vision related information and the filename in GigE Vision is UTF8 coded, this filename is also UTF8 coded.</p> <p>Data type: STRING</p> |
| BUFFER_INFO_PIXEL_ENDIANNESS | 26 | <p>Endianness of the multi-byte pixel data in the buffer. This information refers to the constants defined in <code>PIXELENDIANNESS_IDS</code>.</p> <p>Data type: INT32</p> |
| BUFFER_INFO_DATA_SIZE | 27 | <p>Size of the data intended to be written to the buffer last time it has been filled. This value is reset to 0 when the buffer is placed into the Input Buffer Pool. If the buffer is incomplete the number still reports the full size of</p> |

| Enumerator | Value | Description |
|-------------------------------------|-------|---|
| | | the original data, including the lost parts. If the buffer is complete, the number equals to the size reported through BUFFER_INFO_SIZE_FILLED. Data type: SIZET |
| BUFFER_INFO_TIMESTAMP_NS | 28 | Timestamp the buffer was acquired, in units of 1 ns (1 000 000 000 ticks per second). If the device is internally using another tick frequency than 1MHz, the GenTL Producer must convert the value to nanoseconds. Data type: UINT64 |
| BUFFER_INFO_DATA_LARGER_THAN_BUFFER | 29 | If this values is set to true it indicates that the payload transferred would not fit into the announced buffer and that therefore only parts of the payload or no payload (depending on the implementation of the GenTL Producer) is copied into the buffer. Data type: BOOL8 |
| BUFFER_INFO_CONTAINS_CHUNKDATA | 30 | If this values is set to true it indicates that the payload transferred contains chunk data which may be parsed through a call to DSGetBufferChunkData or the GenTL Consumer. Data type: BOOL8 |
| BUFFER_INFO_CUSTOM_ID | 1000 | Starting value for GenTL Producer custom IDs which are implementation specific. If a generic GenTL Consumer is using custom BUFFER_INFO_CMDS provided through a specific GenTL Producer implementation it must differentiate the handling of different GenTL Producer implementations in case other implementations will not provide that custom id or will use a different meaning with it. |

6.4.4.5 PAYLOADTYPE_INFO_IDS

enum PAYLOADTYPE_INFO_IDS

This enumeration defines constants to give a hint on the payload type to be expected in the buffer. These values are returned by a call to [DSGetBufferInfo](#) with the command `BUFFER_INFO_PAYLOADTYPE`. The interpretation of the `PAYLOADTYPE_INFO_IDS` is depending on the `TLType` of the device which streams the data.

| Enumerator | Value | Description |
|--------------------------------------|-------|--|
| <code>PAYLOAD_TYPE_UNKNOWN</code> | 0 | The GenTL Producer is not aware of the payload type of the data in the provided buffer. For the GenTL Consumer perspective this can be handled as raw data. |
| <code>PAYLOAD_TYPE_IMAGE</code> | 1 | The buffer payload contains pure image data. In particular, no chunk data is attached to the image. |
| <code>PAYLOAD_TYPE_RAW_DATA</code> | 2 | The buffer payload contains raw, further unspecified data. For instance this can be used to send acquisition statistics. |
| <code>PAYLOAD_TYPE_FILE</code> | 3 | The buffer payload contains data of a file. It is used to transfer files, such as JPEG compressed images, which can be stored by the GenTL Producer directly to a hard disk. The user might get a hint how to interpret the buffer by the filename provided through a call to DSGetBufferInfo with the command <code>BUFFER_INFO_FILENAME</code> . |
| <code>PAYLOAD_TYPE_CHUNK_DATA</code> | 4 | The buffer payload contains chunk data which can be parsed. The chunk data type might be reported through <code>SFNC</code> or deduced from the technology the device is based on. This constant is for backward compatibility with GEV 1.2 and will be deprecated in the future. |
| <code>PAYLOAD_TYPE_JPEG</code> | 5 | The buffer payload contains JPEG data in the format described in GEV 2.0. The GenTL Producer should report additional information through the corresponding |

| Enumerator | Value | Description |
|------------------------------|-------|--|
| | | BUFFER_INFO_CMD commands. |
| PAYLOAD_TYPE_JPEG2000 | 6 | The buffer payload contains JPEG 2000 data in the format described in GEV 2.0. The GenTL Producer should report additional information through the corresponding BUFFER_INFO_CMD commands. |
| PAYLOAD_TYPE_H264 | 7 | The buffer payload contains H.264 data in the format described in GEV 2.0. The GenTL Producer should report additional information through the corresponding BUFFER_INFO_CMD commands. |
| PAYLOAD_TYPE_CHUNK_ONLY | 8 | The buffer payload contains only chunk data but no additional payload. |
| PAYLOAD_TYPE_DEVICE_SPECIFIC | 9 | The buffer payload contains device specific data. The GenTL Producer should report additional information through the corresponding BUFFER_INFO_CMD commands. |
| PAYLOAD_TYPE_CUSTOM_ID | 1000 | Starting value for GenTL Producer custom IDs which are implementation specific. |

6.4.4.6 PIXELFORMAT_NAMESPACE_IDS

```
enum PIXELFORMAT_NAMESPACE_IDS
```

This enumeration defines constants to interpret the pixel formats provided through BUFFER_INFO_PIXELFORMAT.

| Enumerator | Value | Description |
|----------------------------------|-------|---|
| PIXELFORMAT_NAMESPACE_UNKNOWN | 0 | The interpretation of the pixel format values is unknown to the GenTL Producer. |
| PIXELFORMAT_NAMESPACE_GEV | 1 | The interpretation of the pixel format values is referencing GigE Vision 1.x |
| PIXELFORMAT_NAMESPACE_IIDC | 2 | The interpretation of the pixel format values is referencing IIDC 1.x |
| PIXELFORMAT_NAMESPACE_PFNC_16BIT | 3 | The interpretation of the pixel format values is referencing PFNC |

| | | |
|-----------------------|----------------|---|
| GEN<i>i</i>CAM | |  |
| Version 1.4 | GenTL Standard | |

| Enumerator | Value | Description |
|----------------------------------|-------|--|
| | | 16Bit Values |
| PIXELFORMAT_NAMESPACE_PFNC_32BIT | 4 | The interpretation of the pixel format values is referencing PFNC 32Bit Values |
| PIXELFORMAT_NAMESPACE_CUSTOM_ID | 1000 | The interpretation of the pixel format values is GenTL Producer specific. |

6.4.4.7 PIXELENDIANNESS_IDS

```
enum PIXELENDIANNESS_IDS
```

This enumeration defines constants describing endianness of multi-byte pixel data in a buffer. These values are returned by a call to `DSGetBufferInfo` with the command `BUFFER_INFO_PIXELENDIANNESS`.

| Enumerator | Value | Description |
|-------------------------|-------|--|
| PIXELENDIANNESS_UNKNOWN | 0 | Endianness of the pixel data is unknown to the GenTL Producer. |
| PIXELENDIANNESS_LITTLE | 1 | The pixel data is stored in little endian format. |
| PIXELENDIANNESS_BIG | 2 | The pixel data is stored in big endian format. |

6.4.4.8 STREAM_INFO_CMD

```
enum STREAM_INFO_CMD
```

This enumeration defines commands to retrieve information with the [DSGetInfo](#) function on a data stream handle.

| Enumerator | Value | Description |
|---------------------------|-------|--|
| STREAM_INFO_ID | 0 | Unique ID of the data stream. Data type: <code>STRING</code> |
| STREAM_INFO_NUM_DELIVERED | 1 | Number of delivered buffers since last acquisition start. Data type: <code>UINT64</code> |
| STREAM_INFO_NUM_UNDERRUN | 2 | Number of lost frames due to queue underrun. This number is initialized with zero at the time the stream is opened and incremented every time the data could not be acquired because there was no buffer in the input |

| Enumerator | Value | Description |
|---------------------------------|-------|--|
| | | pool. Data type: UINT64 |
| STREAM_INFO_NUM_ANNOUNCED | 3 | Number of announced buffers. Data type: SIZET |
| STREAM_INFO_NUM_QUEUED | 4 | Number of buffers in the input pool plus the buffer(s) currently being filled. This does not include the buffers in the output queue. The intention of this informational value is to prevent/early detect an underrun of the acquisition buffers. Data type: SIZET |
| STREAM_INFO_NUM_AWAIT_DELIVERY | 5 | Number of buffers in the output buffer queue. Data type: SIZET |
| STREAM_INFO_NUM_STARTED | 6 | Number of frames started in the acquisition engine. This number is incremented every time a new buffer is started to be filled (data written to) regardless if the buffer is later delivered to the user or discarded for any reason. This number is initialized with 0 at the time of the stream is opened. It is not reset until the stream is closed. Data type: UINT64 |
| STREAM_INFO_PAYLOAD_SIZE | 7 | Size of the expected data in bytes. Data type: SIZET |
| STREAM_INFO_IS_GRABBING | 8 | Flag indicating whether the acquisition engine is started or not. This is independent from the acquisition status of the remote device. Data type: BOOL8 |
| STREAM_INFO_DEFINES_PAYLOADSIZE | 9 | Flag that indicating that this data stream defines a payload size independent from the remote device. If <code>false</code> the size of the expected payload size is to be retrieved from the remote device. If <code>true</code> the expected payload size is to be inquired from the Data Stream module. Data type: BOOL8 |

| Enumerator | Value | Description |
|------------------------------|-------|--|
| STREAM_INFO_TLTYPE | 10 | Transport layer technology that is supported. See string constants in chapter 6.6.1. Data type: STRING |
| STREAM_INFO_NUM_CHUNKS_MAX | 11 | Maximum number of chunks to be expected in a buffer (can be used to allocate the array for the DSGetBufferChunkData function). In case this is not known a priori by the GenTL Producer the DSGetInfo function returns GC_ERR_NOT_AVAILABLE. This maximum must not change during runtime. Data type: SIZET |
| STREAM_INFO_BUF_ANNOUNCE_MIN | 12 | Minimum number of buffers to announce. In case this is not known a priori by the GenTL Producer the DSGetInfo function returns a GC_ERR_NOT_AVAILABLE error. This minimum may change during runtime when changing parameters through the node map. Data type: SIZET |
| STREAM_INFO_BUF_ALIGNMENT | 13 | Alignment size in bytes of the buffer passed to DSAnnounceBuffer. If a buffer is passed to DSAnnounceBuffer which is not aligned according to the alignment size it is up to the Producer to either reject the buffer and return a GC_ERR_INVALID_BUFFER error code or to cope with a potential overhead and use the unaligned buffer as is. In case there is no special alignment needed the GenTL Producer should report a 1. Data type: SIZET |
| STREAM_INFO_CUSTOM_ID | 1000 | Starting value for GenTL Producer custom IDs which are implementation specific. If a generic GenTL Consumer is using custom |

| Enumerator | Value | Description |
|------------|-------|--|
| | | STREAM_INFO_COMMANDS provided through a specific GenTL Producer implementation it must differentiate the handling of different GenTL Producer implementations in case other implementations will not provide that custom id or will use a different meaning with it. |

6.4.5 Port Enumerations

6.4.5.1 PORT_INFO_CMD

```
enum PORT_INFO_CMD
```

This enumeration defines commands to retrieve information with the [GCGetPortInfo](#) function on a module or remote device handle.

| Enumerator | Value | Description |
|------------------|-------|---|
| PORT_INFO_ID | 0 | Unique ID of the module the port references. In case of the remote device module PORT_INFO_ID returns the same ID as for the local device module. In case of a buffer PORT_INFO_ID returns the address of the buffer as hex string without the leading '0x'. Data type: STRING |
| PORT_INFO_VENDOR | 1 | Port vendor name. In case the underlying module has no explicit vendor the vendor of the GenTL Producer is to be used. So in case of a Buffer or a Datastream the GenTL Producer vendor and model are to be used. Data type: STRING |
| PORT_INFO_MODEL | 2 | Port model name. The port model references the model of the underlying module. So for example if the port is for the configuration of a TLSystem Module the PORT_INFO_MODEL returns the model of the TLSystem Module. |

| Enumerator | Value | Description |
|-------------------------|-------|--|
| | | In case the underlying module has no explicit model the model of the GenTL Producer is to be used. So in case of a Buffer or a Datastream the GenTL Producer model is to be used. Data type: STRING |
| PORT_INFO_TLTYPE | 3 | Transport layer technology that is supported. See string constants in chapter 6.6.1. Data type: STRING |
| PORT_INFO_MODULE | 4 | GenTL Module the port refers to: <ul style="list-style-type: none"> • “TLSystem” for the System module • “TLInterface” for the Interface module • “TLDevice” for the Device module • “TLDataStream” for the Data Stream module • “TLBuffer” for the Buffer module • “Device” for the remote device Data type: STRING |
| PORT_INFO_LITTLE_ENDIAN | 5 | Flag indicating that the port’s data is little endian. Data type: BOOL8 |
| PORT_INFO_BIG_ENDIAN | 6 | Flag indicating that the port’s data is big endian. Data type: BOOL8 |
| PORT_INFO_ACCESS_READ | 7 | Flag indicating that read access is allowed. Data type: BOOL8 |
| PORT_INFO_ACCESS_WRITE | 8 | Flag indicating that write access is allowed. Data type: BOOL8 |
| PORT_INFO_ACCESS_NA | 9 | Flag indicating that the port is currently not available. Data type: BOOL8 |
| PORT_INFO_ACCESS_NI | 10 | Flag indicating that no port is implemented. This is only valid on the Buffer module since on all other modules the port is mandatory. Data type: BOOL8 |
| PORT_INFO_VERSION | 11 | Version of the port. Data type: STRING |
| PORT_INFO_PORTNAME | 12 | Name of the port as referenced in the |

| Enumerator | Value | Description |
|---------------------|-------|---|
| | | XML description. This name is used to connect this port to the nodemap instance of this module. Data type: STRING |
| PORT_INFO_CUSTOM_ID | 1000 | Starting value for GenTL Producer custom IDs which are implementation specific. If a generic GenTL Consumer is using custom PORT_INFO_CMDs provided through a specific GenTL Producer implementation it must differentiate the handling of different GenTL Producer implementations in case other implementations will not provide that custom id or will use a different meaning with it. |

6.4.5.2 URL_INFO_CMD

```
enum URL_INFO_CMD
```

This enumeration defines commands to retrieve information with the [GCGetPortURLInfo](#) function on a module or remote device handle.

| Enumerator | Value | Description |
|----------------------------|-------|---|
| URL_INFO_URL | 0 | URL as defined in chapter 4.1.2 Data type: STRING |
| URL_INFO_SCHEMA_VER_MAJOR | 1 | Major version of the schema this URL refers to. Data type: INT32 |
| URL_INFO_SCHEMA_VER_MINOR | 2 | Minor version of the schema this URL refers to. Data type: INT32 |
| URL_INFO_FILE_VER_MAJOR | 3 | Major version of the XML-file this URL refers to. Data type: INT32 |
| URL_INFO_FILE_VER_MINOR | 4 | Minor version of the XML-file this URL refers to. Data type: INT32 |
| URL_INFO_FILE_VER_SUBMINOR | 5 | Subminor version of the XML-file this URL refers to. Data type: INT32 |
| URL_INFO_FILE_SHA1_HASH | 6 | SHA1 Hash of the XML-file this URL refers to. The size of the provided buffer |

| Enumerator | Value | Description |
|--------------------|-------|--|
| | | is 160Bit according to the SHA1 spec. Data type: BUFFER |
| URL_INFO_CUSTOM_ID | 1000 | Starting value for GenTL Producer custom IDs which are implementation specific. If a generic GenTL Consumer is using custom URL_INFO_CMDS provided through a specific GenTL Producer implementation it must differentiate the handling of different GenTL Producer implementations in case other implementations will not provide that custom id or will use a different meaning with it. |

6.4.6 Signaling Enumerations

6.4.6.1 EVENT_DATA_INFO_CMD

```
enum EVENT_DATA_INFO_CMD
```

This enumeration defines commands to retrieve information with the [EventGetDataInfo](#) function on delivered event data.

The availability and the data type of the enumerators depend on the event type (see below).

| Enumerator | Value | Description |
|----------------------|-------|--|
| EVENT_DATA_ID | 0 | Attribute in the event data to identify the object or feature the event refers to. This can be e.g. the error code for an error event or the feature name for GenApi related events. |
| EVENT_DATA_VALUE | 1 | Defines additional data to an ID. This can be e.g. the error message for an error event. |
| EVENT_DATA_NUMID | 2 | Attribute in the event data to identify the object or feature the event refers to. It is the numeric representation of EVENT_DATA_ID if applicable. In case it is not possible to map EVENT_DATA_ID to a number the EventGetDataInfo function returns GC_ERR_NOT_AVAILABLE. Data type: UINT64 |
| EVENT_DATA_CUSTOM_ID | 1000 | Starting value for GenTL Producer custom IDs which are implementation specific. If a generic GenTL Consumer is using |

| Enumerator | Value | Description |
|------------|-------|---|
| | | custom EVENT_DATA_INFO_CMDS provided through a specific GenTL Producer implementation it must differentiate the handling of different GenTL Producer implementations in case other implementations will not provide that custom id or will use a different meaning with it. |

6.4.6.2 EVENT_INFO_CMD

```
enum EVENT_INFO_CMD
```

This enumeration defines command to retrieve information with the [EventGetInfo](#) function on an event handle.

| Enumerator | Value | Description |
|--------------------------|-------|---|
| EVENT_EVENT_TYPE | 0 | The event type of the event handle. Data type: INT32 (EVENT_TYPE enum value) |
| EVENT_NUM_IN_QUEUE | 1 | Number of events in the event data queue. Data type: SIZET |
| EVENT_NUM FIRED | 2 | Number of events that were fired since the registration of the event through a call to GCRegisterEvent . A fired event is either still in the internal queue or already delivered to the user or discarded through EventFlush. Data type: UINT64 |
| EVENT_SIZE_MAX | 3 | Maximum size in bytes of the event data provided by the event. In case this is not known a priori by the GenTL Producer the EventGetInfo function returns GC_ERR_NOT_AVAILABLE. This max size must not change during runtime. Data type: SIZET |
| EVENT_INFO_DATA_SIZE_MAX | 4 | Maximum size in bytes of the information output buffer of EventGetDataInfo function for EVENT_DATA_VALUE. In case this is not known a priori by the GenTL Producer the EventGetDataInfo function returns a |

| | | |
|-----------------------|----------------|---|
| GEN<i>i</i>CAM | |  |
| Version 1.4 | GenTL Standard | |

| Enumerator | Value | Description |
|----------------------|-------|--|
| | | GC_ERR_NOT_AVAILABLE error. This max size must not change during runtime. Data type: SIZET |
| EVENT_INFO_CUSTOM_ID | 1000 | Starting value for GenTL Producer custom IDs which are implementation specific. If a generic GenTL Consumer is using custom EVENT_INFO_CMDS provided through a specific GenTL Producer implementation it must differentiate the handling of different GenTL Producer implementations in case other implementations will not provide that custom id or will use a different meaning with it. |

6.4.6.3 EVENT_TYPE

```
enum EVENT_TYPE
```

Known event types that can be registered on certain modules with the [GCRegisterEvent](#) function. See chapter 4.2 Signaling page 34 for more information.

Specific values of the event data can be queried with the [EventGetDataInfo](#) function. It is stated in the table which enumerators specify values that can be retrieved by a specific event type.

| Enumerator | Value | Description |
|--------------------------|-------|---|
| EVENT_ERROR | 0 | Notification on module errors. Values that can be retrieved are: <ul style="list-style-type: none"> EVENT_DATA_ID Data type: INT32 (GC_ERROR) EVENT_DATA_VALUE Data type: STRING (Description) |
| EVENT_NEW_BUFFER | 1 | Notification on newly filled buffers. Values that can be retrieved are: <ul style="list-style-type: none"> EVENT_DATA_ID Data type: PTR (Buffer handle) EVENT_DATA_VALUE Data type: PTR (Private pointer) |
| EVENT_FEATURE_INVALIDATE | 2 | Notification if a feature was changed by the GenTL Producer driver and thus needs to be invalidated in the GenICam GenApi |

| Enumerator | Value | Description |
|----------------------|-------|--|
| | | instance using the module. Values that can be retrieved are: <ul style="list-style-type: none"> EVENT_DATA_ID Data type: STRING (Feature name) |
| EVENT_FEATURE_CHANGE | 3 | Notification if the GenTL Producer driver wants to manually set a feature in the GenICam GenApi instance using the module. Values that can be retrieved are: <ul style="list-style-type: none"> EVENT_DATA_ID Data type: STRING (Feature name) EVENT_DATA_VALUE Data type: STRING (Feature value) |
| EVENT_REMOTE_DEVICE | 4 | Notification if the GenTL Producer wants to inform the GenICam GenApi instance of the remote device that a GenApi compatible event was fired. This Event is to be registered on a Local Device module. Values that can be retrieved are: <ul style="list-style-type: none"> EVENT_DATA_ID String representation of the EventID number in hexadecimal numbers with even number of digits and without the leading '0x'. Data type: STRING (Event ID) EVENT_DATA_VALUE Corresponds to the data addressable through the remote device's nodemap event port, beginning of the buffer corresponding to address 0. Data type: BUFFER (optional data) <p>This event type used to be called EVENT_FEATURE_DEVEVENT but has been renamed for a more intuitive understanding.</p> |
| EVENT_MODULE | 5 | Notification that one GenTL Producer module wants to inform the GenICam GenApi instance of this module that a GenApi compatible event was fired. This Event is to be registered on any module handle except on the Remote Device. Values that can be retrieved are: <ul style="list-style-type: none"> EVENT_DATA_ID String representation of the EventID |

| Enumerator | Value | Description |
|-----------------|-------|--|
| | | number in hexadecimal numbers with even number of digits and without the leading '0x'. Data type: STRING (Event ID) |
| EVENT_CUSTOM_ID | 1000 | <ul style="list-style-type: none"> EVENT_DATA_VALUE Corresponds to the data addressable through the module's nodemap event port, beginning of the buffer corresponding to address 0. Data type: BUFFER (optional data) |
| | | Starting value for GenTL Producer custom events which are implementation specific. If a generic GenTL Consumer is using custom EVENT_TYPES provided through a specific GenTL Producer implementation it must differentiate the handling of different GenTL Producer implementations in case other implementations will not provide that custom id or will use a different meaning with it. |

6.5 Structures

Structures are byte aligned. The size of pointers as members is platform dependent.

6.5.1 Signaling Structures

```
struct EVENT_NEW_BUFFER_DATA
```

Structure of the data returned from a signaled "New Buffer" event.

| Member | Type | Description |
|--------------|---------------|--|
| BufferHandle | BUFFER_HANDLE | Buffer handle which contains new data. |
| UserPointer | void * | User pointer provided at announcement of the buffer. |

6.5.2 Port Structures

```
struct PORT_REGISTER_STACK_ENTRY
```

Layout of the array elements being used in the function [GCWritePortStacked](#) and [GCReadPortStacked](#) to accomplish a stacked register read/write operations.

| Member | Type | Description |
|---------|----------|---|
| Address | uint64_t | Register address |
| Buffer | void * | Pointer to the buffer receiving the data being read/containing the data to write. |
| Size | size_t | Number of bytes to read / write. The provided <i>Buffer</i> must be at least that size. |

6.5.3 Generic Chunk Parser Structures

```
struct SINGLE_CHUNK_DATA
```

Layout of the array elements being used in the function [DSGetBufferChunkData](#) to carry information about individual chunks present in the buffer.

| Member | Type | Description |
|-------------|-----------|---|
| ChunkID | uint64_t | Numeric representation of the chunk's ChunkID. |
| ChunkOffset | ptrdiff_t | Offset of the chunk's data from the start of the buffer (in bytes). |
| ChunkLength | size_t | Size of the given chunk data (in bytes). |

6.6 String Constants

6.6.1 Transport Layer Types

String constants for transport layer technologies that are supported. To be used with the xxx_INFO_TLTYPE inquiry commands.

| Transport Technology Standard | String Constant |
|-------------------------------|---|
| GigE Vision | “GEV” |
| Camera Link | “CL” |
| IIDC 1394 | “IIDC” |
| USB video class | “UVC” |
| CoaXPress | “CXP” |
| Camera Link HS | “CLHS” |
| USB3 Vision Standard | “U3V” |
| Generic Ethernet | “Ethernet” |
| PCI / PCIe | “PCI” |
| Mixed | “Mixed” This type is only valid for the System module in |

| | | |
|-----------------------|----------------|---|
| GEN<i>i</i>CAM | |  |
| Version 1.4 | GenTL Standard | |

| Transport Technology Standard | String Constant |
|--|--|
| | case the different Interface modules with a single system are of different types. All other modules must be of a defined type. |
| Non standard transport technology, not covered by other constants. | ”Custom“ |

6.7 Numeric Constants

Numerical constants used in the GenTL Producer API.

| Constant | Value(Type) | Description |
|----------------------|--------------------------------|---|
| GENTL_INVALID_HANDLE | NULL (void *) | This value is indicating an invalid handle for any handle type used within GenTL Producer API. |
| GENTL_INFINITE | 0xFFFFFFFFFFFFFFFF (UINT64) | Value indicating an infinite number (eg timeout or number of buffers), to be used with API functions. |

7 Standard Feature Naming Convention for GenTL

The different GenTL modules expose their features through the Port functions interface. To interpret the virtual register map of each module the GenICam GenApi is used. This document only contains the names of mandatory features that must be implemented to guarantee interoperability between the different GenTL Consumers and GenTL Producers. Additional features and descriptions can be found in the GenICam Standard Feature Naming Convention document (SFNC) and in the GenTL Standard Feature Naming Convention document (GenTL SFNC).

For technical reasons the different transport layer technologies and protocols (GigE Vision, IIDC 1394, Camera Link,...) have different feature sets. This is addressed in dedicated sections specialized on these technologies. Also features specific to one technology have a prefix indicating its origin, e.g. Gev for GigE Vision specific features or Cl for Camera Link specific features. Mixed-type GenTL Producers must implement mandatory features of all supported technologies in the System node map. The mandatory technology specific features falling under the “InterfaceSelector” might be marked not-available (NA) when an interface implementing other technology is currently selected.

Interface, Device, Data Stream and Buffer node maps are unequivocally bound to a particular transfer technology and thus they must implement only technology specific features of the corresponding technology.

When updating features which are related to information covered also in the C interface it might happen that the data, the node map refers to changes unexpectedly. Therefore these values should not be cached in the nodemap but read every time from the module. This especially applies to features under a module selector.

7.1 Common

The common feature set is mandatory for all GenTL Producer implementations and used for all transport layer technologies.

7.1.1 System Module

This is a description of all features which must be accessible in the System module: Port functions use the TL_HANDLE to access these features. The Port access for this module is mandatory.

Table 7-5: System module information features

| Name | Interface | Access | Description |
|--------------|-----------|--------|--|
| TLVendorName | IString | R | Name of the GenTL Producer vendor. |
| TLModelName | IString | R | Name of the GenTL Producer to distinguish different kinds of GenTL Producer implementations from one vendor. |
| TLID | IString | R | Unique ID identifying a GenTL Producer. For example the filename |

| | | |
|-----------------------|----------------|---|
| GEN<i>i</i>CAM | |  |
| Version 1.4 | GenTL Standard | |

| Name | Interface | Access | Description |
|-------------------|--------------|--------|--|
| | | | of the GenTL Producer implementation incl. its path. |
| TLVersion | IString | R | Vendor specific version string. |
| TLPath | IString | R | Full path to the GenTL Producer driver including name and extension. |
| TLType | IEnumeration | R | Identifies the transport layer technology of the GenTL Producer implementation. See chapter 6.6.1 for possible values. |
| GenTLVersionMajor | IInteger | R | Major version number of the GenTL specification the GenTL Producer implementation complies with. |
| GenTLVersionMinor | IInteger | R | Minor version number of the GenTL specification the GenTL Producer implementation complies with. |

Table 7-6: Interface enumeration features

| Name | Interface | Access | Description |
|------------------------------------|-----------|--------|---|
| InterfaceUpdateList | ICommand | (R)/W | Updates the internal interface list. This feature should be readable if the execution cannot be performed immediately. The command then returns and the status can be polled. This function interacts with the TLUUpdateInterfaceList of the GenTL Producer. It is up to the GenTL Consumer to handle access in case both methods are used. |
| InterfaceSelector | IInteger | R/W | Selector for the different GenTL Producer interfaces. This interface list only changes on execution of InterfaceUpdateList. The selector is 0-based in order to match the index of the C interface. |
| InterfaceID [InterfaceSelector] | IString | R | GenTL Producer wide unique identifier of the selected interface. This interface list only changes on execution of InterfaceUpdateList. |

7.1.2 Interface Module

All features that must be accessible in the interface module are listed here: Port functions use the IF_HANDLE to access these features. The Port access for this module is mandatory.

| | | |
|-----------------------|----------------|---|
| GEN<i>i</i>CAM | |  |
| Version 1.4 | GenTL Standard | |

Table 7-7: Interface information features

| Name | Interface | Access | Description |
|---------------|--------------|--------|--|
| InterfaceID | IString | R | GenTL Producer wide unique identifier of the selected interface. |
| InterfaceType | IEnumeration | R | Identifies the transport layer technology of the interface. See chapter 6.6.1 for possible values. |

Table 7-8: Device enumeration features

| Name | Interface | Access | Description |
|--|--------------|--------|---|
| DeviceUpdateList | ICommand | (R)/W | Updates the internal device list. This feature should be readable if the execution cannot be performed immediately. The command then returns and the status can be polled. This function interacts with the IFUpdateDeviceList function of the GenTL Producer. It is up to the GenTL Consumer to handle access in case both methods are used. |
| DeviceSelector | IInteger | R/W | Selector for the different devices on this interface. This value only changes on execution of "DeviceUpdateList". The selector is 0-based in order to match the index of the C interface. |
| DeviceID [DeviceSelector] | IString | R | Interface wide unique identifier of the selected device. This value only changes on execution of "DeviceUpdateList". |
| DeviceVendorName [DeviceSelector] | IString | R | Name of the device vendor. This value only changes on execution of "DeviceUpdateList". |
| DeviceModelName [DeviceSelector] | IString | R | Name of the device model. This value only changes on execution of "DeviceUpdateList". |
| DeviceAccessStatus [DeviceSelector] | IEnumeration | R | Gives the device's access status at the moment of the last execution of "DeviceUpdateList". This value only changes on execution of "DeviceUpdateList". Values: <ul style="list-style-type: none"> • "ReadWrite" for full access • "ReadOnly" for read-only access |

| | | |
|-----------------------|----------------|---|
| GEN<i>i</i>CAM | |  |
| Version 1.4 | GenTL Standard | |

| Name | Interface | Access | Description |
|------|-----------|--------|---|
| | | | <ul style="list-style-type: none"> • “NoAccess” if another device has exclusive access |

7.1.3 Device Module

Contains all features which must be accessible in the Device module: Port functions use the DEV_HANDLE to access these features. The Port access for this module is mandatory.

Do not mistake this Device module Port access with the remote device Port access. This module represents the GenTL Producer’s view on the remote device. The remote device port is retrieved via the [DevGetPort](#) function returning a PORT_HANDLE for the remote device.

Table 7-9: Device information features

| Name | Interface | Access | Description |
|------------------|--------------|--------|---|
| DeviceID | IString | R | Interface wide unique identifier of this device. |
| DeviceVendorName | IString | R | Name of the device vendor. |
| DeviceModelName | IString | R | Name of the device model. |
| DeviceType | IEnumeration | R | Identifies the transport layer technology of the device. See chapter 6.6.1 for possible values. |

Table 7-10: Stream enumeration features

| Name | Interface | Access | Description |
|------------------------------|-----------|--------|---|
| StreamSelector | IInteger | R/W | Selector for the different stream channels The selector is 0-based in order to match the index of the C interface. |
| StreamID [StreamSelector] | IString | R | Device unique ID for the stream, e.g. a GUID. |

7.1.4 Data Stream Module

This section lists all features which must be available in the stream module: Port functions use the DS_HANDLE to access the features. The Port access for this module is mandatory.

Table 7-11: Data Stream information features

| Name | Interface | Access | Description |
|----------------------------|-----------|--------|--|
| StreamID | IString | R | Device unique ID for the data stream, e.g. a GUID. |
| StreamAnnouncedBufferCount | IInteger | R | Number of announced (known) buffers on this stream. This value is volatile. It may change if additional buffers are announced and/or buffers |

| Name | Interface | Access | Description |
|-------------------------------|--------------|--------|--|
| | | | are revoked by the GenTL Consumer. |
| StreamAcquisitionModeSelector | IEnumeration | R/W | Available buffer handling modes of this Stream. Deprecated. Use “StreamBufferHandlingMode” instead. Value: “Default” (see chapter 5 Acquisition Engine page 42ff) |
| StreamBufferHandlingMode | IEnumeration | R/W | Available buffer handling modes of this Stream. Value: “Default” (see chapter 5 Acquisition Engine page 42ff) |
| StreamAnnounceBufferMinimum | IInteger | R | Minimal number of buffers to announce to enable selected buffer handling mode. |
| StreamType | IEnumeration | R | Identifies the transport layer technology of the stream. See chapter 6.6.1 for possible values. |

7.1.5 Buffer Module

All features that must be accessible on a buffer if a Port access is provided are listed here. Port functions use the BUFFER_HANDLE to access these features. The Port access for the BUFFER_HANDLE is not mandatory. Thus all features listed here need not be implemented. If a Port access is implemented on the handle though, all mandatory features must be present.

Table 7-12: Buffer information features

| Name | Interface | Access | Description |
|----------------|-----------|--------|--|
| BufferData | IRegister | R/(W) | Entire buffer data. |
| BufferUserData | IInteger | R | Pointer to user data (pPrivate) casted to an integer number referencing GenTL Consumer specific data. It is reflecting the pointer provided by the user data pointer (<i>pPrivate</i>) at buffer announcement. (see chapter 6.3.5 Data Stream Functions page 81ff). This allows the GenTL Consumer to attach information to a buffer. |